

R3G630-FK60-23 ebmpapst Datasheet

sales@fansco.com

www.fansco.com

Limited partnership · Headquarters Mulfingen

Amtsgericht (court of registration) Stuttgart · HRA 590344

General partner Elektrobau Mulfingen GmbH · Headquarters Mulfingen

Amtsgericht (court of registration) Stuttgart · HRB 590142

## Nominal data

Type	R3G630-FK60-23	
Motor	M3G112-GA	
Phase		1~
Nominal voltage	VAC	230
Nominal voltage range	VAC	200 .. 277
Frequency	Hz	50/60
Method of obtaining data		ml
Speed (rpm)	min <sup>-1</sup>	820
Power consumption	W	750
Current draw	A	3.3
Min. ambient temperature	°C	-40
Max. ambient temperature	°C	40

ml = Max. load · me = Max. efficiency · fa = Free air · cs = Customer specification · ce = Customer equipment  
Subject to change

## Data according to Commission Regulation (EU) 327/2011 (EN 17166)

		Actual	Req. 2015			
01 Overall efficiency $\eta_{es}$	%	68.9	50.2	09 Power consumption $P_{ed}$	kW	0.75
02 Measurement category		A		09 Air flow $q_v$	m <sup>3</sup> /h	8135
03 Efficiency category		Static		09 Pressure increase $p_{fs}$	Pa	210
04 Efficiency grade N		80.7	62	10 Speed (rpm) n	min <sup>-1</sup>	825
05 Variable speed drive		Yes		11 Specific ratio <sup>*</sup>		1.00

Data obtained at optimum efficiency level.

The ErP data is determined using a motor-impeller combination in a standardized measurement setup.

<sup>\*</sup> Specific ratio =  $1 + p_{fs} / 100\,000\text{ Pa}$ 

LU-196651



## Technical description

Weight	15.7 kg
Size	630 mm
Motor size	112
Rotor surface	Painted black
Terminal box material	PP plastic
Electronics housing material	Die-cast aluminum
Impeller material	PP plastic
Number of blades	6
Direction of rotation	Clockwise, viewed toward rotor
Degree of protection	IP55
Insulation class	"F"
Moisture (F) / Environmental (H) protection class	H1
Ambient temperature note	Occasional start-up at temperatures between -40°C and -25°C is permitted. For continuous operation at ambient temperatures below -25°C (such as refrigeration applications), use must be made of a fan design with special low-temperature bearings.
Max. permitted ambient temp. for motor (transport/storage)	+80 °C
Min. permitted ambient temp. for motor (transport/storage)	-40 °C
Installation position	Shaft horizontal or rotor on bottom; rotor on top on request
Condensation drainage holes	On rotor side
Mode	S1
Motor bearing	Ball bearing
Technical features	<ul style="list-style-type: none"> <li>- Output 10 VDC, max. 10 mA</li> <li>- Operation and alarm display</li> <li>- Alarm relay</li> <li>- Integrated PID controller</li> <li>- Power limiter</li> <li>- Motor current limitation</li> <li>- PFC, active</li> <li>- RS-485 MODBUS-RTU</li> <li>- Soft start</li> <li>- Control input 0-10 VDC / PWM</li> <li>- Control interface with SELV potential safely disconnected from the mains</li> <li>- Thermal overload protection for electronics/motor</li> <li>- Line undervoltage / phase failure detection</li> </ul>
EMC immunity to interference	According to EN 61000-6-2 (industrial environment)
EMC circuit feedback	According to EN 61000-3-2/3
EMC interference emission	According to EN 61000-6-3 (household environment)
Touch current according to IEC 60990 (measuring circuit Fig. 4, TN system)	<= 3.5 mA
Electrical hookup	Terminal box
Motor protection	Thermal overload protector (TOP) internally connected
With cable	Variable
Protection class	I (with customer connection of protective earth)
Conformity with standards	EN 61800-5-1; CE
Approval	CSA C22.2 No. 77 + CAN/CSA-E60730-1; EAC; UL 1004-7 + 60730-1

Product drawing

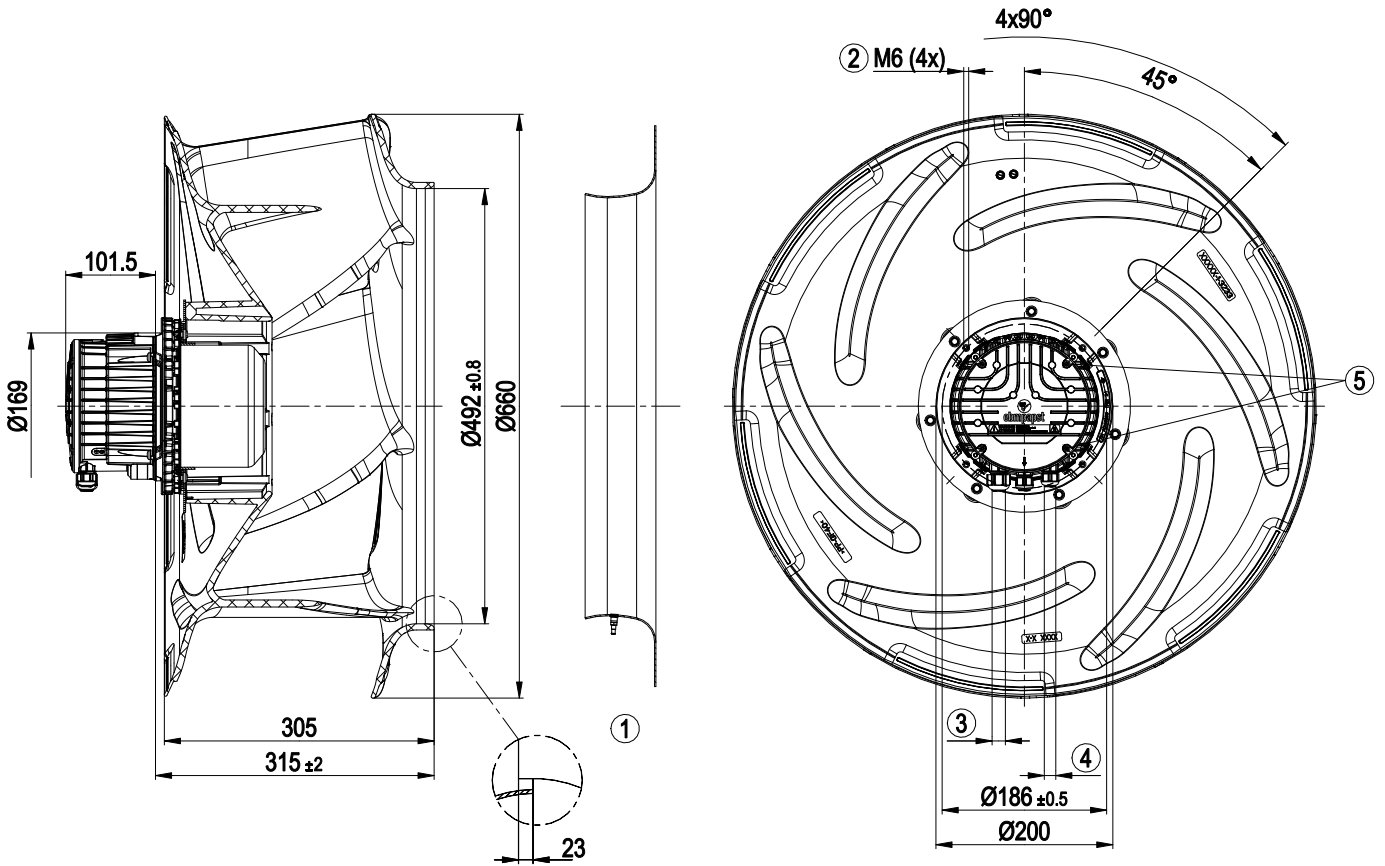

1	Accessory part: Inlet ring 63355-2-4013 with pressure tap (k-factor 545) not included in scope of delivery
2	Max. clearance for screw 16 mm
3	Cable diameter min. 8 mm, max. 12 mm, tightening torque $1.8 \pm 0.3$ Nm (use must be made of seal provided) Cable diameter min. 4 mm, max. 10 mm, tightening torque $1.8 \pm 0.3$ Nm
4	Cable diameter min. 6 mm, max. 10 mm, tightening torque $1.8 \pm 0.3$ Nm (use must be made of seal provided) Cable diameter min. 4 mm, max. 7 mm, tightening torque $1.8 \pm 0.3$ Nm
5	Tightening torque $1.5 \pm 0.2$ Nm



## Accessory part

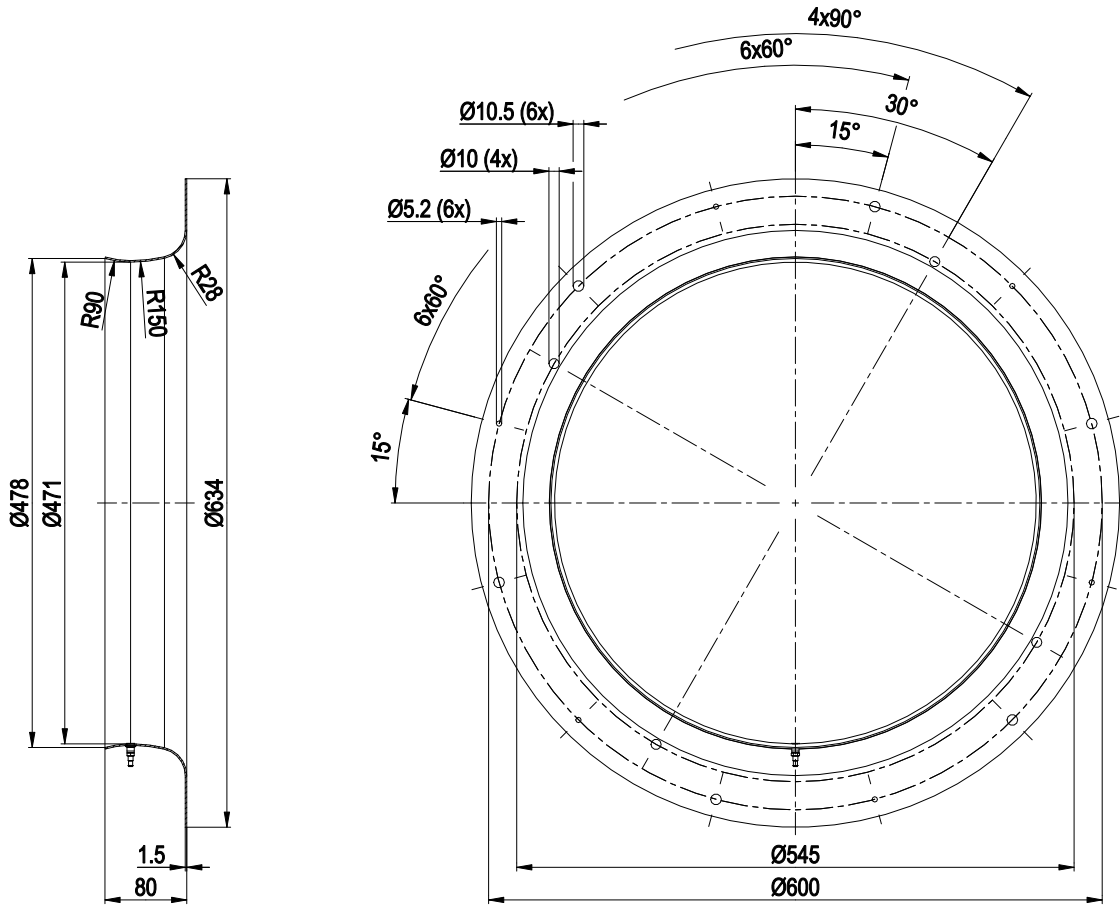

Inlet ring 63355-2-4013 with pressure tap (k-factor 545)

## Connection diagram

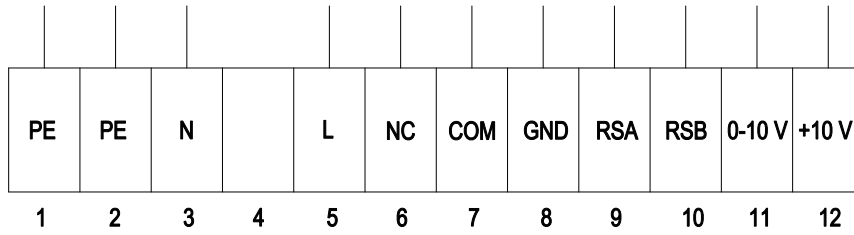

No.	Conn.	Designation	Function/assignment
1	PE	PE	Protective earth
2	PE	PE	Protective earth
3	N	N	Power supply, neutral conductor
4	-	-	not used
5	L	L	Power supply, phase
6	NC	NC	Status relay, floating status contact, break for failure, contact rating 250 VAC / 2 A (AC1) / min. 10 mA; basic insulation on supply side and reinforced insulation on control interface side
7	COM	COM	Status relay, floating status contact, common connection, contact rating 250 VAC / 2 A (AC1) / min. 10 mA; basic insulation on supply side and reinforced insulation on control interface side
8	GND	GND	Reference ground for control interface, SELV
9	RSA	RSA	RS485 interface for MODBUS, RSA; SELV
10	RSB	RSB	RS485 interface for MODBUS, RSB; SELV
11	0-10 V	0-10 V	Analog input (set value) SELV, 0-10 V, Ri = 100 kΩ, adjustable curve
12	+10 V	+10 V	Fixed voltage output 10 VDC, SELV, +10 V ±3%, max. 10 mA, short-circuit-proof, power supply for external devices (e.g. pot)

## Curves: Air performance 50 Hz

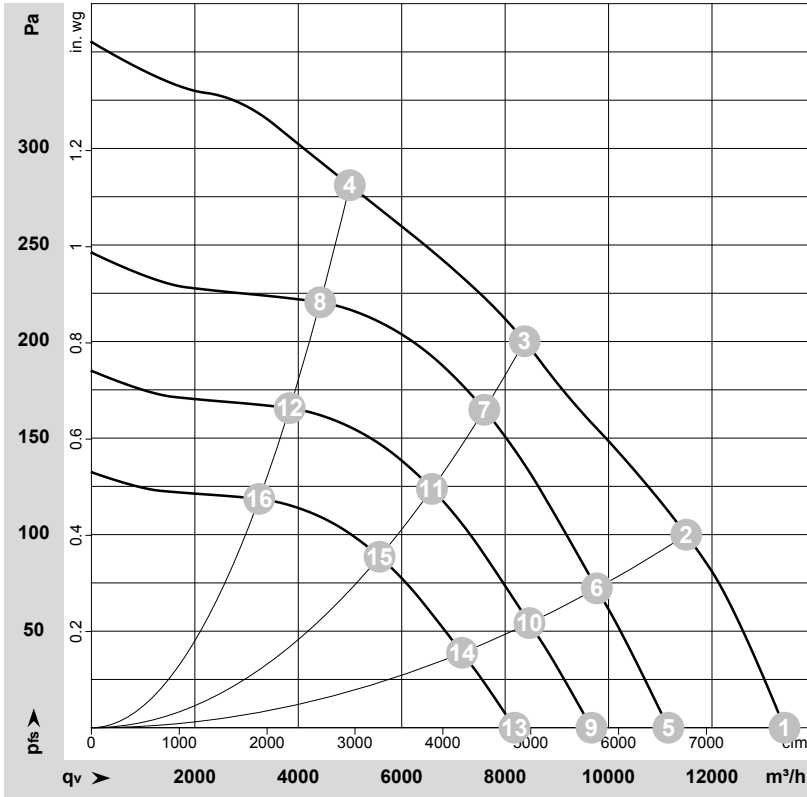

$\rho = 1.15 \text{ kg/m}^3 \pm 2 \%$

Measurement: LU-196651-1

Air performance measured according to ISO 5801 installation category A. For detailed information on the measurement setup, contact ebmpapst. Intake sound level: Sound power level according to ISO 13347 / sound pressure level measured at 1 m distance from fan axis. The values given are valid under the specified measuring conditions and may vary due to conditions of installation. For deviations from the standard configuration, the parameters have to be checked on the installed unit.

## Measured values

	Wired	U	f	n	P <sub>ed</sub>	I	LpA <sub>in</sub>	LwA <sub>in</sub>	LwA <sub>out</sub>	q <sub>v</sub>	p <sub>fs</sub>	q <sub>v</sub>	p <sub>fs</sub>
		V	Hz	min <sup>-1</sup>	W	A	dB(A)	dB(A)	dB(A)	m <sup>3</sup> /h	Pa	cfm	in. wg
1	1~	230	50	900	573	2.52	74	78	80	13405	0	7890	0.00
2	1~	230	50	885	750	3.30	67	75	79	11500	100	6770	0.40
3	1~	230	50	820	750	3.30	59	67	71	8375	200	4930	0.80
4	1~	230	50	845	750	3.30	61	69	73	4995	280	2940	1.12
5	1~	230	50	750	330	1.45	70	73	76	11155	0	6565	0.00
6	1~	230	50	750	458	2.00	63	71	75	9775	72	5750	0.29
7	1~	230	50	750	561	2.45	57	65	69	7600	165	4470	0.66
8	1~	230	50	750	524	2.29	58	66	70	4425	220	2605	0.88
9	1~	230	50	650	215	0.94	66	70	72	9670	0	5690	0.00
10	1~	230	50	650	298	1.30	59	68	71	8470	54	4985	0.22
11	1~	230	50	650	365	1.60	53	61	65	6585	124	3875	0.50
12	1~	230	50	650	341	1.49	54	62	66	3835	166	2255	0.67
13	1~	230	50	550	130	0.57	62	66	68	8180	0	4815	0.00
14	1~	230	50	550	181	0.79	55	63	67	7165	39	4220	0.16
15	1~	230	50	550	221	0.97	49	57	61	5570	89	3280	0.36
16	1~	230	50	550	207	0.90	50	58	62	3245	119	1910	0.48

Wired = Wiring · U = Voltage · f = Frequency · n = Speed (rpm) · P<sub>ed</sub> = Power consumption · I = Current draw · LpA<sub>in</sub> = Sound pressure level intake side · LwA<sub>in</sub> = Sound power level intake side · LwA<sub>out</sub> = Sound power level outlet side · q<sub>v</sub> = Air flow · p<sub>fs</sub> = Pressure increase

