

R3G630-FB32-61 ebmpapst Datasheet

sales@fansco.com

www.fansco.com

Limited partnership · Headquarters Mulfingen

Amtsgericht (court of registration) Stuttgart · HRA 590344

General partner Elektrobau Mulfingen GmbH · Headquarters Mulfingen

Amtsgericht (court of registration) Stuttgart · HRB 590142

Nominal data

Type	R3G630-FB32-61	
Motor	M3G150-IF	
Phase		3~
Nominal voltage	VAC	400
Nominal voltage range	VAC	380 .. 480
Frequency	Hz	50/60
Method of obtaining data		ml
Status		prelim.
Speed (rpm)	min ⁻¹	1420
Power consumption	W	3700
Current draw	A	5.7
Min. ambient temperature	°C	-40
Max. ambient temperature	°C	40

ml = Max. load · me = Max. efficiency · fa = Free air · cs = Customer specification · ce = Customer equipment
Subject to change

Data according to Commission Regulation (EU) 327/2011 (EN 17166)

		Actual	Req. 2015			
01 Overall efficiency η_{es}	%	71.4	57.4	09 Power consumption P_{ed}	kW	3.66
02 Measurement category		A		09 Air flow q_v	m ³ /h	12685
03 Efficiency category		Static		09 Pressure increase p_{fs}	Pa	711
04 Efficiency grade N		76	62	10 Speed (rpm) n	min ⁻¹	1420
05 Variable speed drive		Yes		11 Specific ratio [*]		1.01

Data obtained at optimum efficiency level.

^{*} Specific ratio = $1 + p_{fs} / 100\,000\text{ Pa}$

LU-194121

The efficiency values displayed for achieving conformity with the Ecodesign Regulation EU 327/2011 has been reached with defined air duct components (e.g. inlet rings).

The dimensions must be requested from ebm-papst. If other air conduction geometries are used on the installation side, the ebm-papst evaluation loses its validity/the conformity must be confirmed again.

The product does not fall within the scope of Regulation (EU) 2019/1781 due to the exception specified in Article 2 (2a) (motors completely integrated into a product).



Technical description

Weight	28.7 kg
Size	630 mm
Motor size	150
Rotor surface	Painted black
Electronics housing material	Die-cast aluminum, painted gray
Impeller material	PP plastic
Number of blades	6
Direction of rotation	Clockwise, viewed toward rotor
Degree of protection	IP55
Insulation class	"F"
Moisture (F) / Environmental (H) protection class	H2+
Ambient temperature note	Occasional start-up at temperatures between -40°C and -25°C is permitted. For continuous operation at ambient temperatures below -25°C (such as refrigeration applications), use must be made of a fan design with special low-temperature bearings.
Max. permitted ambient temp. for motor (transport/storage)	+80 °C
Min. permitted ambient temp. for motor (transport/storage)	-40 °C
Installation position	Shaft horizontal or rotor on bottom; rotor on top on request
Condensation drainage holes	On rotor side
Mode	S1
Motor bearing	Ball bearing; (sealed)
Technical features	<ul style="list-style-type: none"> - Operation and alarm display with LED - External 15-50 VDC input (parameterization) - Alarm relay - Integrated PI controller - Configurable inputs/outputs (I/O) - MODBUS V6.3 - Motor current limitation - RS-485 MODBUS-RTU - Soft start - Voltage output 3.3-24 VDC, Pmax = 800 mW - Control interface with SELV potential safely disconnected from the mains - Thermal overload protection for electronics/motor - Line undervoltage / phase failure detection
EMC immunity to interference	According to EN 61000-6-2 (industrial environment)
EMC interference emission	According to EN 61000-6-3 (household environment), except EN 61000-3-2 for professionally used equipment with a total rated power greater than 1 kW
Touch current according to IEC 60990 (measuring circuit Fig. 4, TN system)	<= 3.5 mA
Electrical hookup	Terminal box
Protection class	I (with customer connection of protective earth)
Conformity with standards	EN 61800-5-1; CE
Approval	CSA C22.2 No. 77 + CAN/CSA-E60730-1; EAC; UL 1004-7 + 60730-1

Product drawing

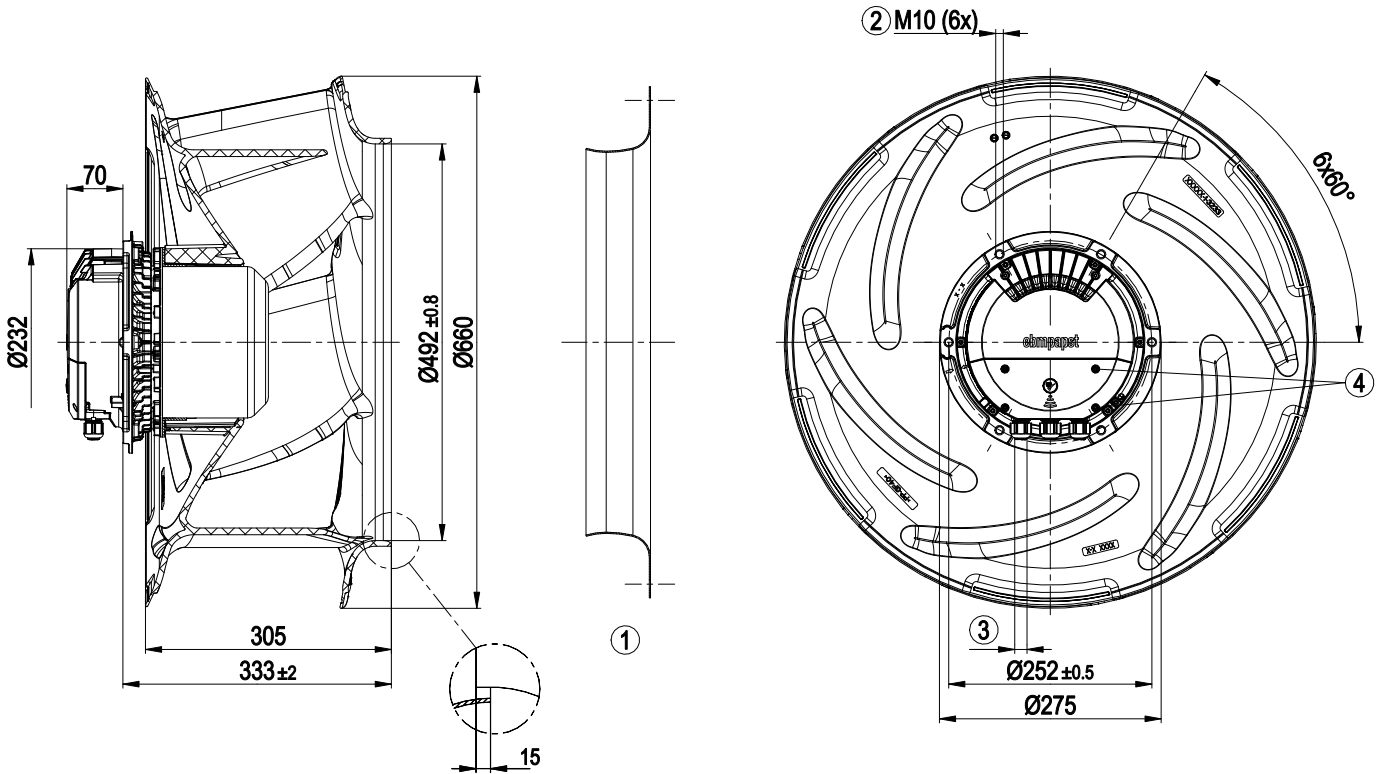

1	Accessory part: Inlet ring 63350-2-4013 not included in scope of delivery
2	Max. clearance for screw 20 mm
3	Cable diameter min. 4 mm, max. 10 mm, tightening torque 4 ± 0.6 Nm (The tightening torque is designed for PVC cables. If the cable materials are different, the tightening torque may have to be adjusted)
4	Tightening torque 1.5 ± 0.2 Nm



Accessory part

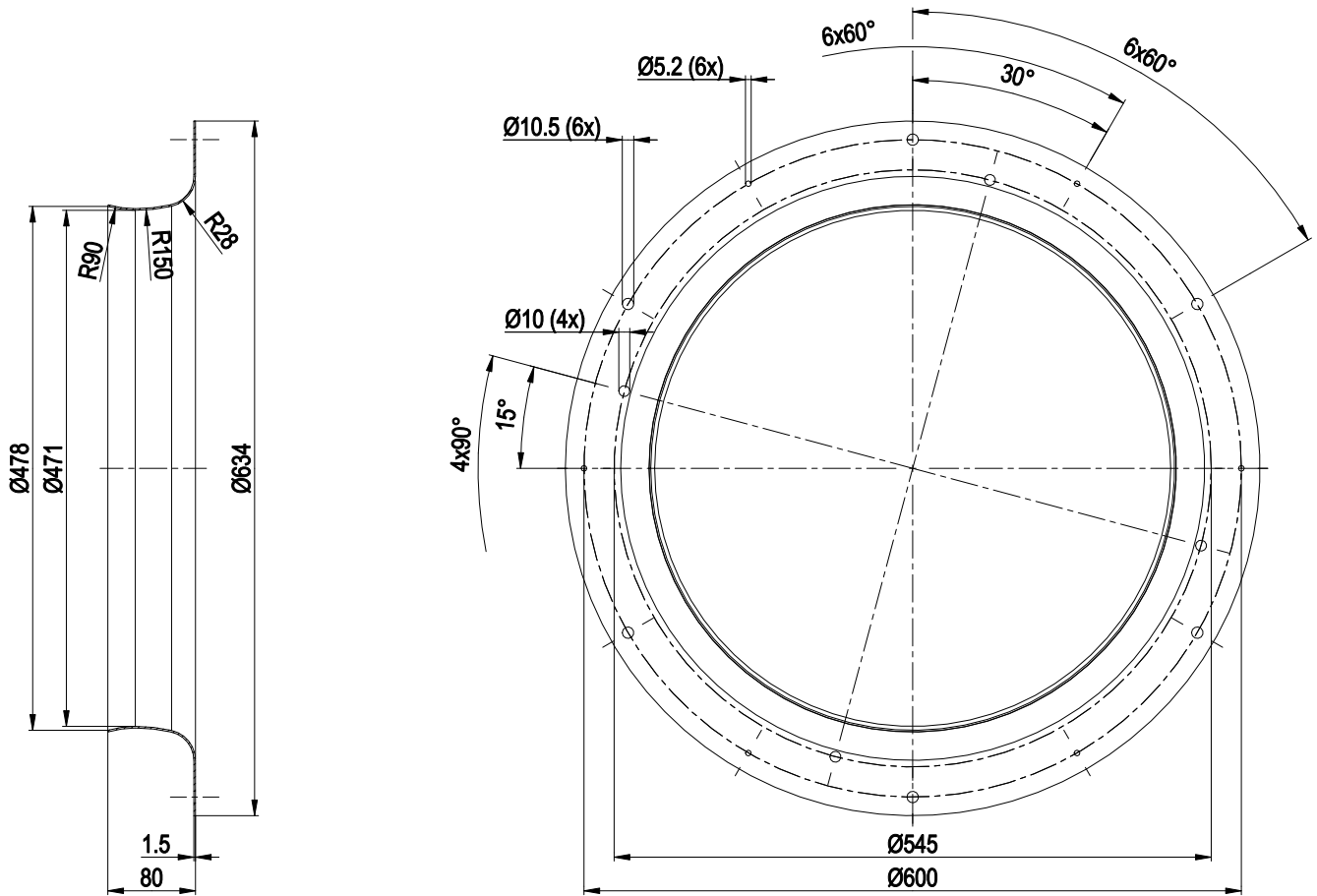

Inlet ring 63350-2-4013



Connection diagram

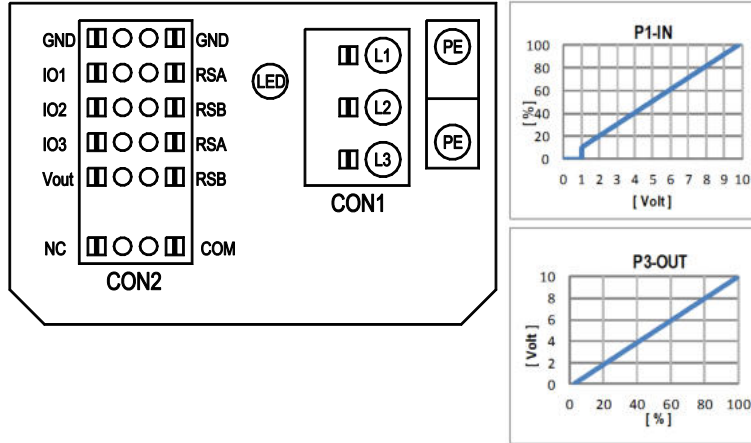

No.	Conn.	Designation	Function/assignment
	CON1	L1, L2, L3	Power supply, phase, see nameplate for voltage range
	PE	PE	Protective earth
	CON2	RSA	RS485 interface for MODBUS, RSA; SELV
	CON2	RSB	RS485 interface for MODBUS, RSB; SELV
	CON2	GND	Reference ground for control interface, SELV
	CON2	IO1	Function parameterizable (see "Optional interface functions" table) Factory setting: Digital input - high active, function: Disable input, SELV - inactive: Pin open or applied voltage < 1.5 VDC - active: applied voltage 3.5-50 VDC Reset function: Triggering of error reset on change of state from "enabled" to "disabled"
	CON2	IO2	Function parameterizable (see "Optional interface functions" table) Factory setting: Analog input 0-10 V / PWM, Ri=100 kΩ, function: Set value Characteristic curve parameterizable (see input characteristic curve P1-IN), SELV
	CON2	IO3	Function parameterizable (see "Optional interface functions" table) Factory setting: Analog output 0-10 V, max. 5 mA, function: Fan modulation level Characteristic curve parameterizable (see output characteristic curve P3-OUT), SELV
	CON2	Vout	Voltage output 3.3-24 VDC ±5%, Pmax=800 mW, voltage parameterizable Factory setting: 10 VDC short-circuit-proof, supply for external devices, SELV alternatively: 15-50 VDC input for parameterization via MODBUS without line voltage
	CON2	COM	Status relay, floating status contact, common connection, contact rating 250 VAC / 2 A (AC1) / min. 10 mA, reinforced insulation on supply side and on control interface side
	CON2	NC	Status relay, floating status contact, break for failure
		LED	green: status = good, ready for operation orange: status = warning red: status = failure
		P1-IN	Input characteristic curve
		P3-OUT	Output characteristic curve



Terminal/plug assignment

CON2	configurable IO mode	electrical specification	configurable IO functions: normal / inverse	MODBUS Register for IO mode configuration	
				MODBUS Register for IO mode configuration	MODBUS Register for IO mode configuration
IO1	○ Din1 (active high), digital input	active: applied voltage 3.5-50VDC, SELV not active: pin open or applied voltage < 1.5VDC		D158 [0]	
	○ Ain1 0-10V/PWM: analog input	RI = 100k, characteristic curve parameterizable, $f_{PWM} = 1k..10kHz$, SELV		D158 [2]	
	○ Tach out (open collector output)	Umax = 50VDC, Imax = 20mA, SELV		D158 [5]	
	○ Diagnostics out (open collector output)	Umax = 50VDC, Imax = 20mA, SELV		D158 [6]	
IO2	○ Din2 (active high), digital input	active: applied voltage 3.5-50VDC, SELV not active: pin open or applied voltage < 1.5VDC		D159 [0]	
	○ Ain2 0-10V/PWM: analog input	RI = 100k, characteristic curve parameterizable, $f_{PWM} = 1k..10kHz$, SELV		D159 [2]	
	○ Ain2.4-20mA: analog input	RI = 125R, characteristic curve parameterizable, SELV		D159 [3]	
	○ Din3 (active high), digital input	active: applied voltage 3.5-50VDC, SELV not active: pin open or applied voltage < 1.5VDC		D15A [0]	
IO3	○ Din3 (active low), digital input	active: applied voltage < 1.5VDC, SELV not active: pin open or applied voltage 3.5-50VDC		D15A [1]	
	○ PWMIn3: digital input, idle level high	PWM = 40Hz - 10kHz, characteristics parameterizable active: pin open or applied voltage 3.5-50VDC not active: applied voltage < 1.5VDC, SELV		D15A [7]	
	○ PWMIn3: digital input, idle level low	active: applied voltage 3.5-50VDC not active: pin open or applied voltage < 1.5VDC, SELV		D15A [8]	
	○ Aout3 0-10V: analog output	function parameterizable, max. 5mA max output frequency 300Hz SELV		D15A [4]	
RSA	○ Tacho out (pulses), analog output	0-10V/max. 5mA max output frequency 300Hz SELV		D15A [5]	
	○ Diagnostics out (pulses)	0-10V/max. 5mA max output frequency 300Hz, SELV		D15A [6]	
	○ Diagnostics out (pulses)	MODBUS RTU, specification V6.3, SELV			
RSB	RS485 bus connection,				
Vout	voltage output	voltage parameterizable 3.3..24VDC +/- 5%, Pmax=600mW, short-circuit-proof, supply for external devices, SELV		D16E [..]	
	alternatively: Input auxiliary power supply for parameterization via RS485/MODBUS RTU without line voltage	15..50VDC			

○ configurable option

For further information and additional functions see EC Control Software, Fan-Set-App, or MODBUS Parameter Specification V6.3



Curves: Air performance 50 Hz

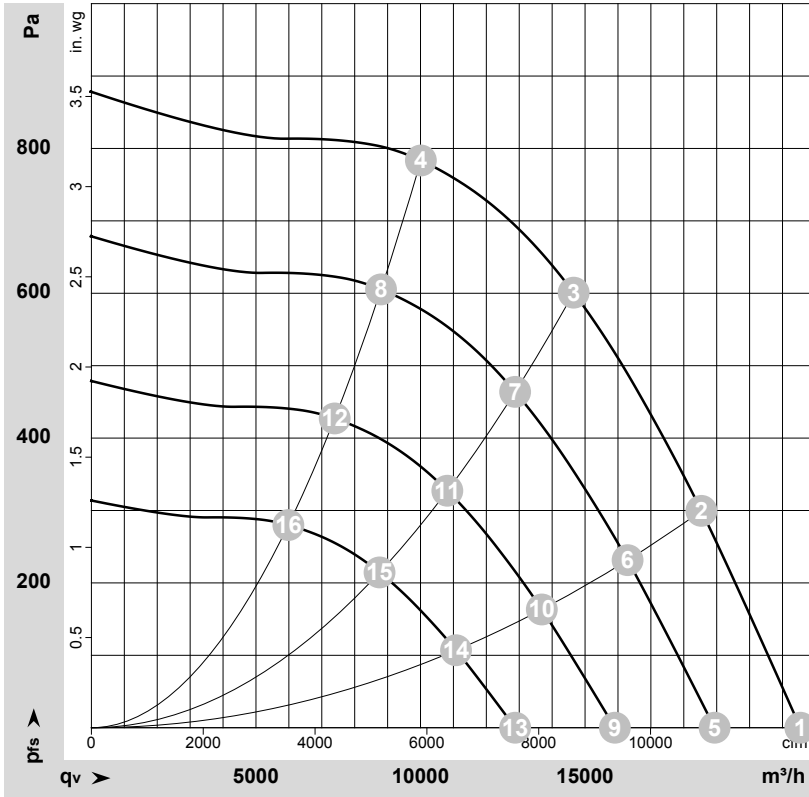

$\rho = 1.15 \text{ kg/m}^3 \pm 2 \%$

Measurement: LU-194121-1

Air performance measured according to ISO 5801 installation category A. For detailed information on the measurement setup, contact ebmpapst. Intake sound level: Sound power level according to ISO 13347 / sound pressure level measured at 1 m distance from fan axis. The values given are valid under the specified measuring conditions and may vary due to conditions of installation. For deviations from the standard configuration, the parameters have to be checked on the installed unit.

Measured values

	Wired	U	f	n	P _{ed}	I	LpA _{in}	LwA _{in}	LwA _{out}	q _v	P _{fs}	q _v	P _{fs}
		V	Hz	min ⁻¹	W	A	dB(A)	dB(A)	dB(A)	m ³ /h	Pa	cfm	in. wg
1	3~	400	50	1420	2234	3.47	81	89	92	21540	0	12680	0.00
2	3~	400	50	1420	3118	4.78	80	86	89	18535	300	10910	1.20
3	3~	400	50	1420	3700	5.70	73	81	85	14655	600	8625	2.41
4	3~	400	50	1420	3520	5.38	73	81	85	10010	780	5890	3.13
5	3~	400	50	1250	1517	2.36	78	86	89	18935	0	11145	0.00
6	3~	400	50	1250	2118	3.25	77	83	85	16295	232	9590	0.93
7	3~	400	50	1250	2514	3.84	70	78	82	12875	465	7580	1.87
8	3~	400	50	1250	2391	3.65	70	78	82	8800	609	5180	2.44
9	3~	400	50	1050	899	1.40	74	82	84	15905	0	9365	0.00
10	3~	400	50	1050	1255	1.92	73	78	81	13685	164	8055	0.66
11	3~	400	50	1050	1490	2.27	65	73	77	10815	328	6365	1.32
12	3~	400	50	1050	1417	2.16	65	73	77	7390	430	4350	1.73
13	3~	400	50	850	477	0.74	68	76	79	12875	0	7580	0.00
14	3~	400	50	850	666	1.02	67	73	76	11080	107	6520	0.43
15	3~	400	50	850	791	1.21	60	68	72	8755	215	5155	0.86
16	3~	400	50	850	752	1.15	60	68	72	5985	282	3520	1.13

Wired = Wiring · U = Voltage · f = Frequency · n = Speed (rpm) · P_{ed} = Power consumption · I = Current draw · LpA_{in} = Sound pressure level intake side · LwA_{in} = Sound power level intake side
 LwA_{out} = Sound power level outlet side · q_v = Air flow · P_{fs} = Pressure increase

