

R3G630-FB32-07 ebmpapst Datasheet

sales@fansco.com

www.fansco.com

Limited partnership · Headquarters Mulfingen

Amtsgericht (court of registration) Stuttgart · HRA 590344

General partner Elektrobau Mulfingen GmbH · Headquarters Mulfingen

Amtsgericht (court of registration) Stuttgart · HRB 590142

## Nominal data

|                          |                   |            |
|--------------------------|-------------------|------------|
| Type                     | R3G630-FB32-07    |            |
| Motor                    | M3G150-IF         |            |
| Phase                    |                   | 3~         |
| Nominal voltage          | VAC               | 400        |
| Nominal voltage range    | VAC               | 380 .. 480 |
| Frequency                | Hz                | 50/60      |
| Method of obtaining data |                   | ml         |
| Status                   |                   | prelim.    |
| Speed (rpm)              | min <sup>-1</sup> | 1420       |
| Power consumption        | W                 | 3700       |
| Current draw             | A                 | 5.7        |
| Min. ambient temperature | °C                | -40        |
| Max. ambient temperature | °C                | 45         |

ml = Max. load · me = Max. efficiency · fa = Free air · cs = Customer specification · ce = Customer equipment  
Subject to change

## Data according to Commission Regulation (EU) 327/2011 (EN 17166)

|                                   |   | Actual | Req. 2015 |                                |                   |       |
|-----------------------------------|---|--------|-----------|--------------------------------|-------------------|-------|
| 01 Overall efficiency $\eta_{es}$ | % | 71.4   | 57.4      | 09 Power consumption $P_{ed}$  | kW                | 3.66  |
| 02 Measurement category           |   | A      |           | 09 Air flow $q_v$              | m <sup>3</sup> /h | 12685 |
| 03 Efficiency category            |   | Static |           | 09 Pressure increase $p_{fs}$  | Pa                | 711   |
| 04 Efficiency grade N             |   | 76     | 62        | 10 Speed (rpm) n               | min <sup>-1</sup> | 1420  |
| 05 Variable speed drive           |   | Yes    |           | 11 Specific ratio <sup>*</sup> |                   | 1.01  |

Data obtained at optimum efficiency level.

<sup>\*</sup> Specific ratio =  $1 + p_{fs} / 100\,000\text{ Pa}$ 

LU-194121

The efficiency values displayed for achieving conformity with the Ecodesign Regulation EU 327/2011 has been reached with defined air duct components (e.g. inlet rings).

The dimensions must be requested from ebm-papst. If other air conduction geometries are used on the installation side, the ebm-papst evaluation loses its validity/the conformity must be confirmed again.

The product does not fall within the scope of Regulation (EU) 2019/1781 due to the exception specified in Article 2 (2a) (motors completely integrated into a product).



## Technical description

|  |   |
|--|---|
| Weight   | 28.5 kg   |
| Size   | 630 mm  |
| Motor size   | 150   |
| Rotor surface  | Painted black   |
| Electronics housing material   | Die-cast aluminum   |
| Impeller material  | PP plastic  |
| Number of blades   | 6   |
| Direction of rotation  | Clockwise, viewed toward rotor  |
| Degree of protection   | IP55  |
| Insulation class   | "F"   |
| Moisture (F) / Environmental (H) protection class                          | H1  |
| Ambient temperature note   | Occasional start-up at temperatures between -40°C and -25°C is permitted. For continuous operation at ambient temperatures below -25°C (such as refrigeration applications), use must be made of a fan design with special low-temperature bearings.  |
| Max. permitted ambient temp. for motor (transport/storage)                 | +80 °C  |
| Min. permitted ambient temp. for motor (transport/storage)                 | -40 °C  |
| Installation position  | Shaft horizontal or rotor on bottom; rotor on top on request  |
| Condensation drainage holes  | On rotor side   |
| Mode   | S1  |
| Motor bearing  | Ball bearing  |
| Technical features   | <ul style="list-style-type: none"> <li>- Operation and alarm display with LED</li> <li>- External 15-50 VDC input (parameterization)</li> <li>- Alarm relay</li> <li>- Integrated PI controller</li> <li>- Configurable inputs/outputs (I/O)</li> <li>- MODBUS V6.3</li> <li>- Motor current limitation</li> <li>- RS-485 MODBUS-RTU</li> <li>- Soft start</li> <li>- Voltage output 3.3-24 VDC, Pmax = 800 mW</li> <li>- Control interface with SELV potential safely disconnected from the mains</li> <li>- Thermal overload protection for electronics/motor</li> <li>- Line undervoltage / phase failure detection</li> </ul> |
| EMC immunity to interference   | According to EN 61000-6-2 (industrial environment)  |
| EMC interference emission  | According to EN 61000-6-3 (household environment), except EN 61000-3-2 for professionally used equipment with a total rated power greater than 1 kW   |
| Touch current according to IEC 60990 (measuring circuit Fig. 4, TN system) | <= 3.5 mA   |
| Electrical hookup  | Connector with cable  |
| Protection class assignment  | I; If a protective earth is connected by the customer<br>This component for installation may have several local protection classes. This information relates to this component's basic design.<br>The final protection class is based on the component's intended installation and connection.  |
| Conformity with standards  | EN 61800-5-1; CE  |
| Approval   | CSA C22.2 No. 77 + CAN/CSA-E60730-1; EAC; UL 1004-7 + 60730-1   |

Product drawing

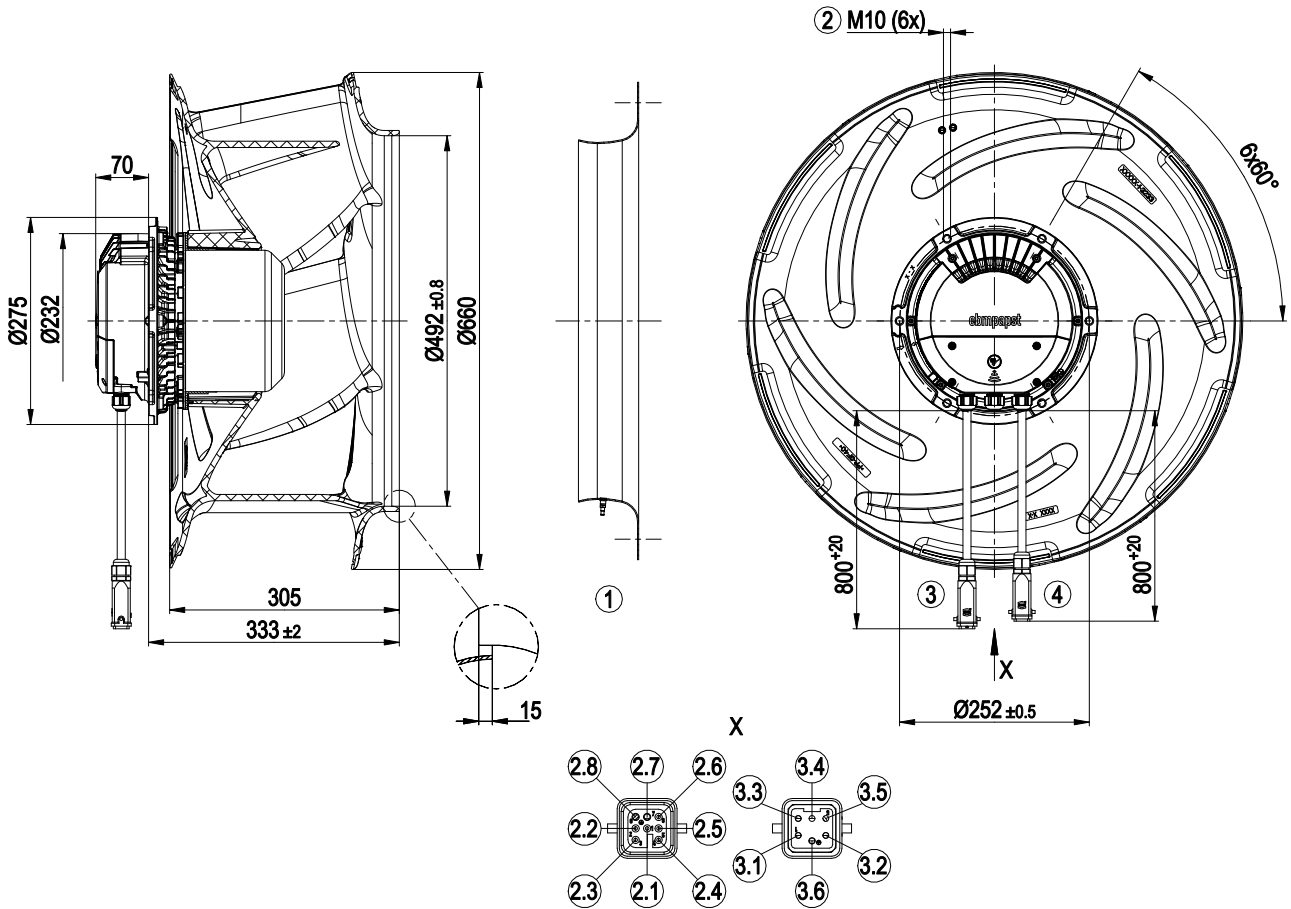

|     |  |
|-----|--|
| 1   | Accessory part: Inlet ring 63355-2-4013 with pressure tap (k-factor 545) not included in scope of delivery   |
| 2   | Cable Ölflex 150 quattro 7G 1.0 mm <sup>2</sup><br>Supply line with connector housing Harting 19 20 003 0420 and pin insert Harting 09 21 007 3031 |
| 2.1 | NC   |
| 2.2 | COM  |
| 2.3 | GND  |
| 2.4 | 0-10 V   |
| 2.5 | RSA  |
| 2.6 | RSB  |
| 2.7 | not used   |
| 2.8 | not used   |
| 3   | Cable Ölflex 150 quattro 4G 1.5 mm <sup>2</sup><br>Supply line with connector housing Harting 19 20 003 0420 and pin insert Harting 09 12 005 3001 |
| 3.1 | L1   |
| 3.2 | L2   |
| 3.3 | L3   |
| 3.4 | not used   |
| 3.5 | not used   |
| 3.6 | PE   |



Accessory part

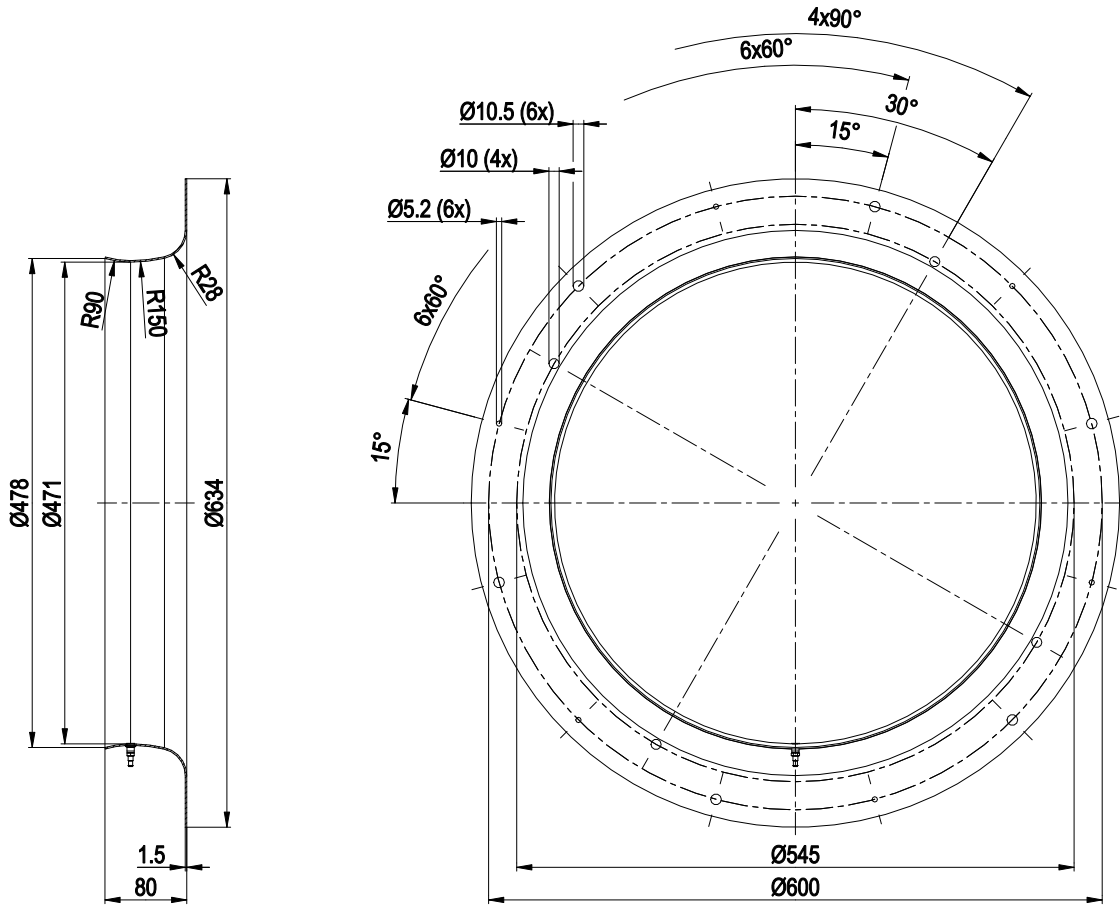

Inlet ring 63355-2-4013 with pressure tap (k-factor 545)



# EC centrifugal fan - RadiCal

backward-curved, single-intake

## Connection diagram

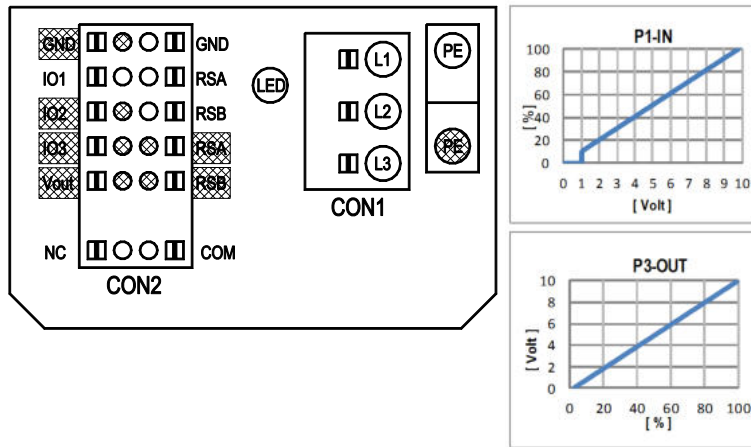

shaded gray => not brought out via leads

| No. | Conn. | Designation | Function/assignment   |
|-----|-------|-------------|---|
|     | CON1  | L1, L2, L3  | Power supply, phase, see nameplate for voltage range  |
|     | PE    | PE          | Protective earth  |
|     | CON2  | RSA         | RS485 interface for MODBUS, RSA; SELV   |
|     | CON2  | RSB         | RS485 interface for MODBUS, RSB; SELV   |
|     | CON2  | GND         | Reference ground for control interface, SELV  |
|     | CON2  | IO1         | Function parameterizable (see "Optional interface functions" table)<br>Factory setting:<br>Digital input - high active, function: Disable input, SELV<br>- inactive: Pin open or applied voltage < 1.5 VDC<br>- active: applied voltage 3.5-50 VDC<br>Reset function: Triggering of error reset on change of state from "enabled" to "disabled" |
|     | CON2  | IO2         | Function parameterizable (see "Optional interface functions" table)<br>Factory setting:<br>Analog input 0-10 V/PWM, Ri=100 kΩ, function: Set value<br>Characteristic curve parameterizable (see input characteristic curve P1-IN), SELV   |
|     | CON2  | IO3         | Function parameterizable (see "Optional interface functions" table)<br>Factory setting:<br>Analog output 0-10 V, max. 5 mA, function: Fan modulation level<br>Characteristic curve parameterizable (see output characteristic curve P3-OUT), SELV   |
|     | CON2  | Vout        | Voltage output 3.3-24 VDC ±5%, Pmax=800 mW, voltage parameterizable<br>Factory setting: 10 VDC<br>short-circuit-proof, supply for external devices, SELV<br>alternatively: 15-50 VDC input for parameterization via MODBUS without line voltage   |
|     | CON2  | COM         | Status relay, floating status contact, common connection, contact rating 250 VAC / 2 A (AC1) / min. 10 mA, reinforced insulation on supply side and on control interface side   |
|     | CON2  | NC          | Status relay, floating status contact, break for failure  |
|     |       | LED         | green: status = good, ready for operation<br>orange: status = warning<br>red: status = failure  |
|     |       | P1-IN       | Input characteristic curve  |
|     |       | P3-OUT      | Output characteristic curve   |



## Terminal/plug assignment

| CON2 | configurable IO mode   | electrical specification   | configurable IO functions: normal / inverse | MODBUS Register for IO mode configuration |   |
|------|--|--|---|---|---|
|      |  |  |   | MODBUS Register for IO mode configuration | MODBUS Register for IO mode configuration |
| IO1  | ○ Din1 (active high), digital input  | active: applied voltage 3.5-50VDC, SELV<br>not active: pin open or applied voltage < 1.5VDC  |   | D158 [0]                                  |   |
|      | ○ Ain1 0-10V/PWM: analog input   | RI = 100k, characteristic curve parameterizable, $f_{PWM} = 1k..10kHz$ , SELV  |   | D158 [2]                                  |   |
|      | ○ Tach out (open collector output)   | Umax = 50VDC, Imax = 20mA, SELV  |   | D158 [5]                                  |   |
|      | ○ Diagnostics out (open collector output)  | Umax = 50VDC, Imax = 20mA, SELV  |   | D158 [6]                                  |   |
| IO2  | ○ Din2 (active high), digital input  | active: applied voltage 3.5-50VDC, SELV<br>not active: pin open or applied voltage < 1.5VDC  |   | D159 [0]                                  |   |
|      | ○ Ain2 0-10V/PWM: analog input   | RI = 100k, characteristic curve parameterizable, $f_{PWM} = 1k..10kHz$ , SELV  |   | D159 [2]                                  |   |
|      | ○ Ain2 4-20mA: analog input  | RI = 125R, characteristic curve parameterizable, SELV  |   | D159 [3]                                  |   |
|      | ○ Din3 (active high), digital input  | active: applied voltage 3.5-50VDC, SELV<br>not active: pin open or applied voltage < 1.5VDC  |   | D15A [0]                                  |   |
| IO3  | ○ Din3 (active low), digital input   | active: applied voltage < 1.5VDC, SELV<br>not active: pin open or applied voltage 3.5-50VDC  |   | D15A [1]                                  |   |
|      | ○ PWMIn3: digital input, idle level high   | PWM = 40Hz - 10kHz, characteristics parameterizable<br>active: pin open or applied voltage 3.5-50VDC<br>not active: applied voltage < 1.5VDC, SELV |   | D15A [7]                                  |   |
|      | ○ PWMIn3: digital input, idle level low  | active: applied voltage 3.5-50VDC<br>not active: pin open or applied voltage < 1.5VDC, SELV  |   | D15A [8]                                  |   |
|      | ○ Aout3 0-10V: analog output   | function parameterizable, max. 5mA max output frequency 300Hz SELV   |   | D15A [4]                                  |   |
| RSA  | ○ Tacho out (pulses), analog output  | 0-10V/max. 5mA max output frequency 300Hz SELV   |   | D15A [5]                                  |   |
|      | ○ Diagnostics out (pulses)   | 0-10V/max. 5mA max output frequency 300Hz, SELV  |   | D15A [6]                                  |   |
|      | ○ Diagnostics out (pulses)   | MODBUS RTU, specification V6.3, SELV   |   |   |   |
| RSB  | RS485 bus connection,  |  |   |   |   |
| Vout | voltage output   | voltage parameterizable 3.3..24VDC +/- 5%, Pmax=600mW, short-circuit-proof, supply for external devices, SELV                                      |   | D16E [..]                                 |   |
|      | alternatively: Input auxiliary power supply for parameterization via RS485/MODBUS RTU without line voltage | 15..50VDC  |   |   |   |

| IO                              | Function  | Signal | Direction | Source | Set Value | Switch | Control Function | Direction of Rotation | Set Value Source | Switch | Fan Enable / Disable | Tach Out | Diagnostics Out | Fan Modulation Level % | Actual Speed | System Modulation Level % | Remote Control Output 0-10V | Pulse Input for Auto-Addressing | Pulse Output for Auto-Addressing |  |
|---------------------------------|---|--------|-----------|--------|-----------|--------|------------------|-----------------------|------------------|--------|----------------------|----------|-----------------|------------------------|--------------|---------------------------|-----------------------------|---------------------------------|----------------------------------|--|
| D101 [..]                       | source: set value   |        |           | ○      |           |        |                  |                       |                  |        |                      |          |                 |                        |              |                           |                             |                                 |                                  |  |
| D147 [..]                       | source: sensor value                                      |        |           | ○      |           |        |                  |                       |                  |        |                      |          |                 |                        |              |                           |                             |                                 |                                  |  |
| D104 [..]                       | switch: parameter set: #1 / #2                            |        |           | ○      |           |        |                  |                       |                  |        |                      |          |                 |                        |              |                           |                             |                                 |                                  |  |
| D12E [..]                       | switch: control function: heating (pos.) / cooling (neg.) |        |           | ○      |           |        |                  |                       |                  |        |                      |          |                 |                        |              |                           |                             |                                 |                                  |  |
| D148 [..]                       | switch: direction of rotation: cw / ccw                   |        |           | ○      |           |        |                  |                       |                  |        |                      |          |                 |                        |              |                           |                             |                                 |                                  |  |
| D16C [..]                       | switch: set value source                                  |        |           | ○      |           |        |                  |                       |                  |        |                      |          |                 |                        |              |                           |                             |                                 |                                  |  |
| D16A [..]                       | switch: fan enable / disable                              |        |           | ○      |           |        |                  |                       |                  |        |                      |          |                 |                        |              |                           |                             |                                 |                                  |  |
| (selected directly via IO mode) | signal: tach out  |        |           | ○      |           |        |                  |                       |                  |        |                      |          |                 |                        |              |                           |                             |                                 |                                  |  |
| (selected directly via IO mode) | signal: diagnostics out                                   |        |           | ○      |           |        |                  |                       |                  |        |                      |          |                 |                        |              |                           |                             |                                 |                                  |  |
| D130 [0]                        | signal: fan modulation level %                            |        |           |        |           |        |                  |                       |                  |        |                      |          |                 |                        | ○            |                           |                             |                                 |                                  |  |
| D130 [1]                        | signal: actual speed                                      |        |           |        |           |        |                  |                       |                  |        |                      |          |                 |                        | ○            |                           |                             |                                 |                                  |  |
| D130 [2]                        | signal: system modulation level %                         |        |           |        |           |        |                  |                       |                  |        |                      |          |                 |                        | ○            |                           |                             |                                 |                                  |  |
| D130 [5]                        | signal: remote control output 0-10V                       |        |           |        |           |        |                  |                       |                  |        |                      |          |                 |                        | ○            |                           |                             |                                 |                                  |  |
| D00C [1]                        | pulse input for auto-addressing                           |        |           |        |           |        |                  |                       |                  |        |                      |          |                 |                        |              |                           |                             | ○                               |                                  |  |
| D130 [4]                        | pulse output for auto-addressing                          |        |           |        |           |        |                  |                       |                  |        |                      |          |                 |                        |              |                           |                             |                                 | ○                                |  |

○ configurable option  
For further information and additional functions see EC Control Software, Fan-Set-App, or MODBUS Parameter Specification V6.3



## Curves: Air performance 50 Hz

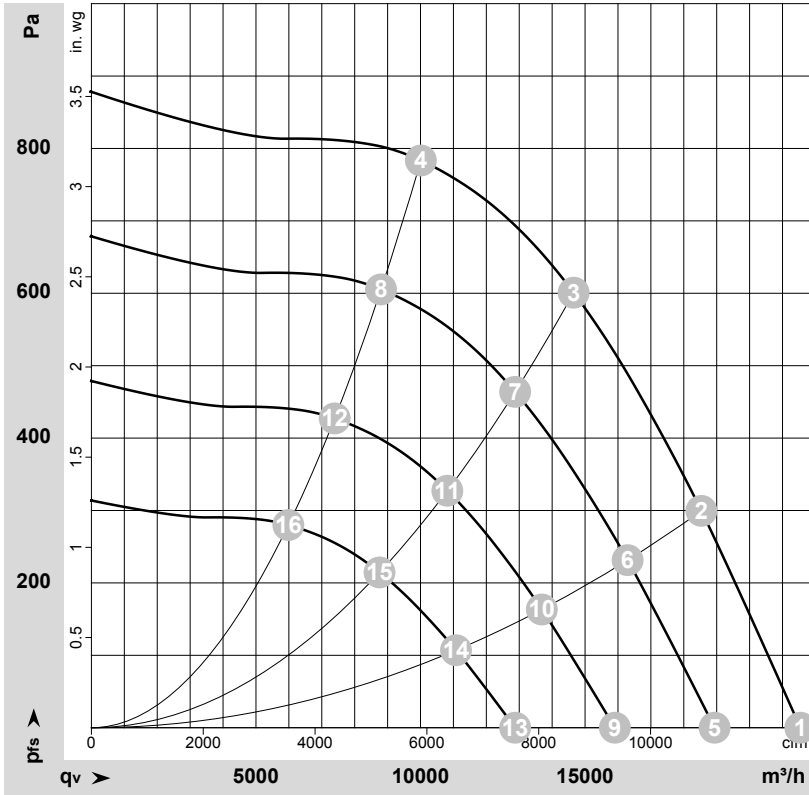

$\rho = 1.15 \text{ kg/m}^3 \pm 2 \%$

Measurement: LU-194121-1

Air performance measured according to ISO 5801 installation category A. For detailed information on the measurement setup, contact ebmpapst. Intake sound level: Sound power level according to ISO 13347 / sound pressure level measured at 1 m distance from fan axis. The values given are valid under the specified measuring conditions and may vary due to conditions of installation. For deviations from the standard configuration, the parameters have to be checked on the installed unit.

## Measured values

|    | Wired | U   | f  | n                 | P <sub>ed</sub> | I    | LpA <sub>in</sub> | LwA <sub>in</sub> | LwA <sub>out</sub> | q <sub>v</sub>    | P <sub>fs</sub> | q <sub>v</sub> | P <sub>fs</sub> |
|----|-------|-----|----|-------------------|-----------------|------|-------------------|-------------------|--------------------|-------------------|-----------------|----------------|-----------------|
|    |       | V   | Hz | min <sup>-1</sup> | W               | A    | dB(A)             | dB(A)             | dB(A)              | m <sup>3</sup> /h | Pa              | cfm            | in. wg          |
| 1  | 3~    | 400 | 50 | 1420              | 2234            | 3.47 | 81                | 89                | 92                 | 21540             | 0               | 12680          | 0.00            |
| 2  | 3~    | 400 | 50 | 1420              | 3118            | 4.78 | 80                | 86                | 89                 | 18535             | 300             | 10910          | 1.20            |
| 3  | 3~    | 400 | 50 | 1420              | 3700            | 5.70 | 73                | 81                | 85                 | 14655             | 600             | 8625           | 2.41            |
| 4  | 3~    | 400 | 50 | 1420              | 3520            | 5.38 | 73                | 81                | 85                 | 10010             | 780             | 5890           | 3.13            |
| 5  | 3~    | 400 | 50 | 1250              | 1517            | 2.36 | 78                | 86                | 89                 | 18935             | 0               | 11145          | 0.00            |
| 6  | 3~    | 400 | 50 | 1250              | 2118            | 3.25 | 77                | 83                | 85                 | 16295             | 232             | 9590           | 0.93            |
| 7  | 3~    | 400 | 50 | 1250              | 2514            | 3.84 | 70                | 78                | 82                 | 12875             | 465             | 7580           | 1.87            |
| 8  | 3~    | 400 | 50 | 1250              | 2391            | 3.65 | 70                | 78                | 82                 | 8800              | 609             | 5180           | 2.44            |
| 9  | 3~    | 400 | 50 | 1050              | 899             | 1.40 | 74                | 82                | 84                 | 15905             | 0               | 9365           | 0.00            |
| 10 | 3~    | 400 | 50 | 1050              | 1255            | 1.92 | 73                | 78                | 81                 | 13685             | 164             | 8055           | 0.66            |
| 11 | 3~    | 400 | 50 | 1050              | 1490            | 2.27 | 65                | 73                | 77                 | 10815             | 328             | 6365           | 1.32            |
| 12 | 3~    | 400 | 50 | 1050              | 1417            | 2.16 | 65                | 73                | 77                 | 7390              | 430             | 4350           | 1.73            |
| 13 | 3~    | 400 | 50 | 850               | 477             | 0.74 | 68                | 76                | 79                 | 12875             | 0               | 7580           | 0.00            |
| 14 | 3~    | 400 | 50 | 850               | 666             | 1.02 | 67                | 73                | 76                 | 11080             | 107             | 6520           | 0.43            |
| 15 | 3~    | 400 | 50 | 850               | 791             | 1.21 | 60                | 68                | 72                 | 8755              | 215             | 5155           | 0.86            |
| 16 | 3~    | 400 | 50 | 850               | 752             | 1.15 | 60                | 68                | 72                 | 5985              | 282             | 3520           | 1.13            |

Wired = Wiring · U = Voltage · f = Frequency · n = Speed (rpm) · P<sub>ed</sub> = Power consumption · I = Current draw · LpA<sub>in</sub> = Sound pressure level intake side · LwA<sub>in</sub> = Sound power level intake side · LwA<sub>out</sub> = Sound power level outlet side · q<sub>v</sub> = Air flow · P<sub>fs</sub> = Pressure increase

