

R3G630-FB29-06 ebmpapst Datasheet

sales@fansco.com

www.fansco.com

Limited partnership · Headquarters Mulfingen

Amtsgericht (court of registration) Stuttgart · HRA 590344

General partner Elektrobau Mulfingen GmbH · Headquarters Mulfingen

Amtsgericht (court of registration) Stuttgart · HRB 590142

Nominal data

Type	R3G630-FB29-06	
Motor	M3G150-IF	
Phase		3~
Nominal voltage	VAC	200
Nominal voltage range	VAC	200 .. 240
Frequency	Hz	50/60
Method of obtaining data		ml
Speed (rpm)	min ⁻¹	1380
Power consumption	W	3250
Current draw	A	9.9
Min. ambient temperature	°C	-40
Max. ambient temperature	°C	40

ml = Max. load · me = Max. efficiency · fa = Free air · cs = Customer specification · ce = Customer equipment
Subject to change

Data according to Commission Regulation (EU) 327/2011 (EN 17166)

		Actual	Req. 2015			
01 Overall efficiency η_{es}	%	69.4	56.9	09 Power consumption P_{ed}	kW	3.26
02 Measurement category		A		09 Air flow q_v	m ³ /h	11995
03 Efficiency category		Static		09 Pressure increase p_{fs}	Pa	648
04 Efficiency grade N		74.5	62	10 Speed (rpm) n	min ⁻¹	1350
05 Variable speed drive		Yes		11 Specific ratio [*]		1.01

Data obtained at optimum efficiency level.

The ErP data is determined using a motor-impeller combination in a standardized measurement setup.

^{*} Specific ratio = $1 + p_{fs} / 100\,000\text{ Pa}$

LU-207135



Technical description

Weight	29 kg
Size	630 mm
Motor size	150
Rotor surface	Painted black
Electronics housing material	Die-cast aluminum
Impeller material	PP plastic
Number of blades	6
Direction of rotation	Clockwise, viewed toward rotor
Degree of protection	IP55
Insulation class	"F"
Moisture (F) / Environmental (H) protection class	H1
Ambient temperature note	Occasional start-up at temperatures between -40°C and -25°C is permitted. For continuous operation at ambient temperatures below -25°C (such as refrigeration applications), use must be made of a fan design with special low-temperature bearings.
Max. permitted ambient temp. for motor (transport/storage)	+80 °C
Min. permitted ambient temp. for motor (transport/storage)	-40 °C
Installation position	Shaft horizontal or rotor on bottom; rotor on top on request
Condensation drainage holes	On rotor side
Mode	S1
Motor bearing	Ball bearing
Technical features	<ul style="list-style-type: none"> - Operation and alarm display with LED - External 15-50 VDC input (parameterization) - Alarm relay - Integrated PI controller - Configurable inputs/outputs (I/O) - MODBUS V6.3 - Motor current limitation - RS-485 MODBUS-RTU - Soft start - Voltage output 3.3-24 VDC, Pmax = 800 mW - Control interface with SELV potential safely disconnected from the mains - Thermal overload protection for electronics/motor - Line undervoltage / phase failure detection
EMC immunity to interference	According to EN 61000-6-2 (industrial environment)
EMC interference emission	According to EN 61000-6-3 (household environment)
Touch current according to IEC 60990 (measuring circuit Fig. 4, TN system)	<= 3.5 mA
Electrical hookup	Connector with cable
Protection class	I (with customer connection of protective earth)
Conformity with standards	EN 61800-5-1; CE
Approval	EAC

Product drawing

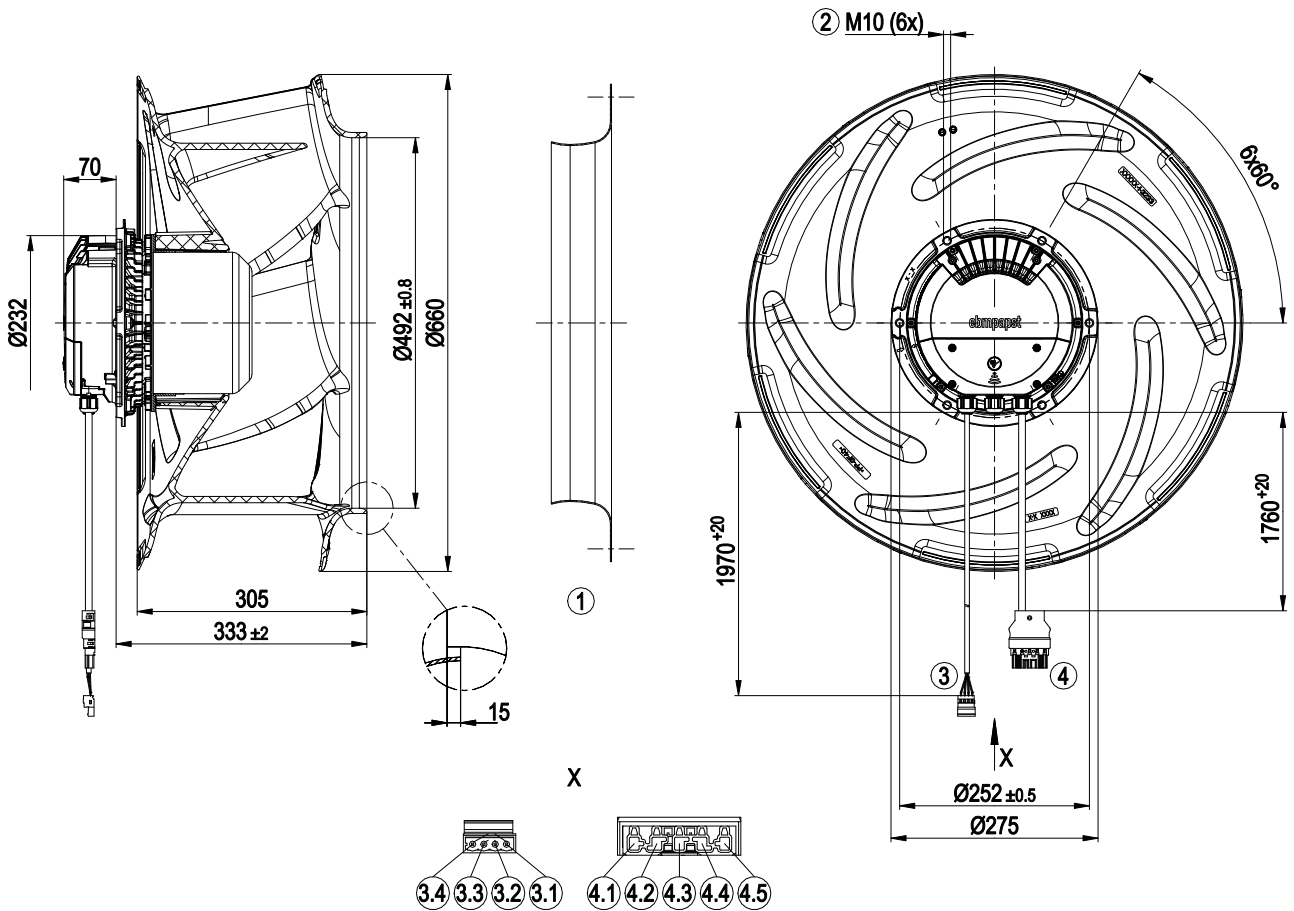

1	Accessory part: Inlet ring 63350-2-4013 not included in scope of delivery
2	Max. clearance for screw 20 mm
3	4-pole header Wago 231-604
3.1	GND
3.2	0-10 V/PWM
3.3	COM
3.4	NC
4	Plug with strain relief 5-pole Wago 0770-001/K011-0174/0000-0300
4.1	not used
4.2	PE
4.3	L1
4.4	L2
4.5	L3

Accessory part

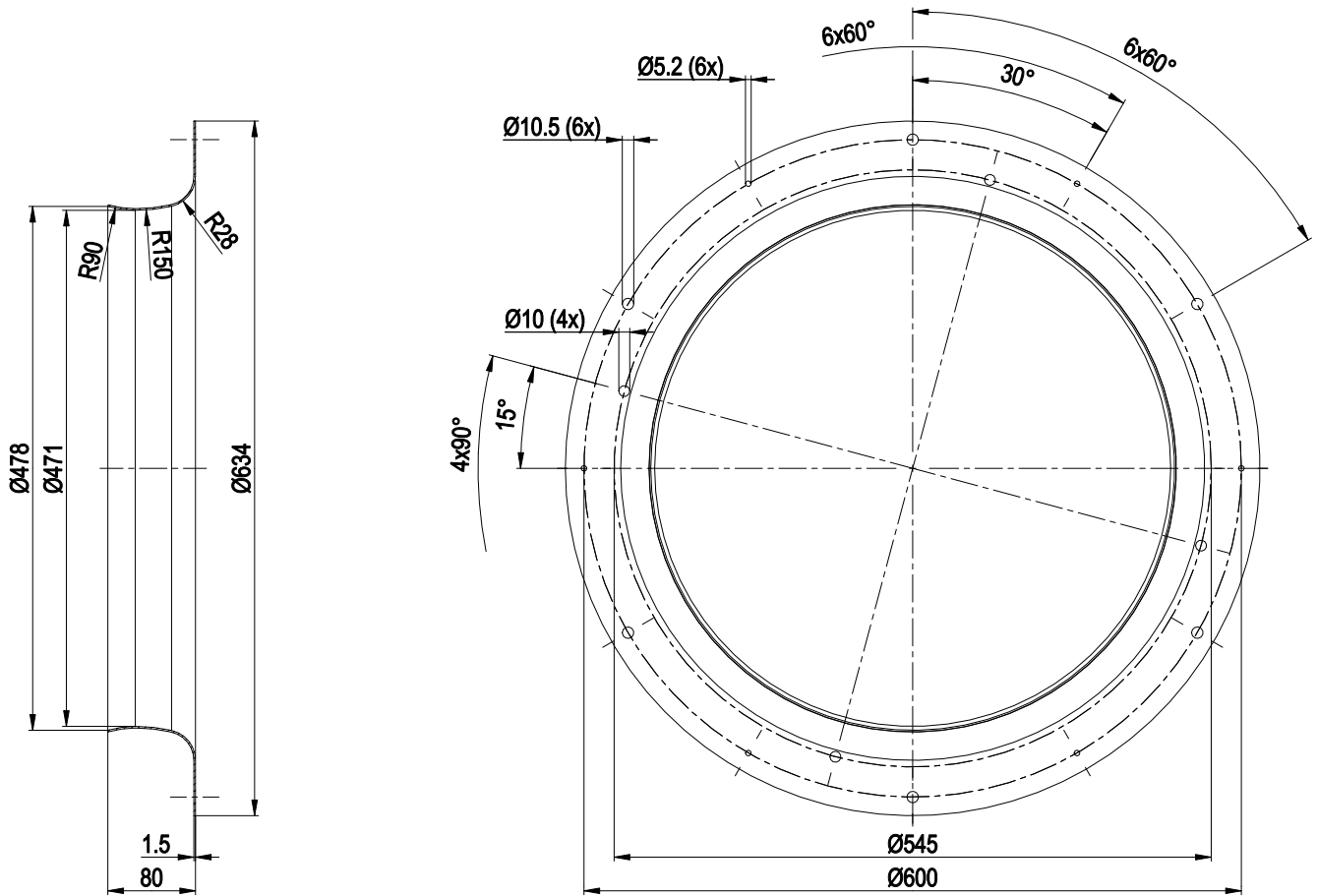

Inlet ring 63350-2-4013

EC centrifugal fan - RadiCal

backward-curved, single-intake

Connection diagram

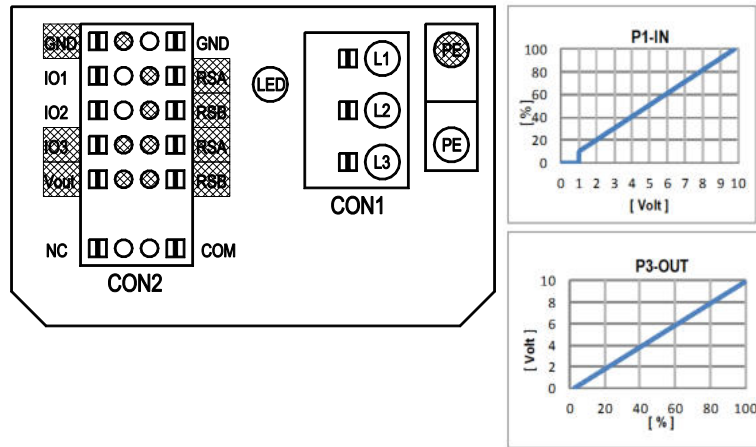

shaded gray => not brought out via leads

No.	Conn.	Designation	Function/assignment
	CON1	L1, L2, L3	Power supply, phase, see nameplate for voltage range
	PE	PE	Protective earth
	CON2	RSA	RS485 interface for MODBUS, RSA; SELV
	CON2	RSB	RS485 interface for MODBUS, RSB; SELV
	CON2	GND	Reference ground for control interface, SELV
	CON2	IO1	Function parameterizable (see "Optional interface functions" table) Factory setting: Digital input - high active, function: Enable input, SELV - inactive: Pin open or applied voltage < 1.5 VDC / < 0.7 VAC - active: applied voltage 3.5-50 VDC / 7-30 VAC Reset function: Triggering of error reset on change of state from "enabled" to "disabled".
	CON2	IO2	Function parameterizable (see "Optional interface functions" table) Factory setting: Analog input 0-10 V / PWM, Ri=100 kΩ, function: Set value Characteristic curve parameterizable (see input characteristic curve P1-IN), SELV
	CON2	IO3	Function parameterizable (see "Optional interface functions" table) Factory setting: Analog output 0-10 V, max. 5 mA, function: Fan modulation level Characteristic curve parameterizable (see output characteristic curve P3-OUT), SELV
	CON2	Vout	Voltage output 3.3-24 VDC ±5%, Pmax=800 mW, voltage parameterizable Factory setting: 10 VDC short-circuit-proof, supply for external devices, SELV alternatively: 15-50 VDC input for parameterization via MODBUS without line voltage
	CON2	COM	Status relay, floating status contact, common connection, contact rating 250 VAC / 2 A (AC1) / min. 10 mA, reinforced insulation on supply side and on control interface side
	CON2	NC	Status relay, floating status contact, break for failure or n < 200 rpm
		LED	green: status = good, ready for operation orange: status = warning red: status = failure
		P1-IN	Input characteristic curve
		P3-OUT	Output characteristic curve



Terminal/plug assignment

CON2	configurable IO mode	electrical specification	configurable IO functions: normal / inverse	MODBUS Register for IO mode configuration	
				source: set value	switch: fan enable / disable
IO1	○ Din1 (active high), digital input	active: applied voltage 3.5-50VDC, SELV not active: pin open or applied voltage < 1.5VDC	D158 [0]	○	○
	○ Ain1 0-10V/PWM: analog input	RI = 100k, characteristic curve parameterizable, f _{PWM} = 1k..10kHz, SELV	D158 [2]	○	○
	○ Tach out (open collector output)	U _{max} = 50VDC, I _{max} = 20mA, SELV	D158 [5]	○	○
	○ Diagnostics out (open collector output)	U _{max} = 50VDC, I _{max} = 20mA, SELV	D158 [6]	○	○
IO2	○ Din2 (active high), digital input	active: applied voltage 3.5-50VDC, SELV not active: pin open or applied voltage < 1.5VDC	D159 [0]	○	○
	○ Ain2 0-10V/PWM: analog input	RI = 100k, characteristic curve parameterizable, f _{PWM} = 1k..10kHz, SELV	D159 [2]	○	○
	○ Ain2 4-20mA: analog input	RI = 125R, characteristic curve parameterizable, SELV	D159 [3]	○	○
	○ Din3 (active high), digital input	active: applied voltage 3.5-50VDC, SELV not active: pin open or applied voltage < 1.5VDC	D15A [0]	○	○
IO3	○ Din3 (active low), digital input	active: applied voltage < 1.5VDC, SELV not active: pin open or applied voltage 3.5-50VDC	D15A [1]	○	○
	○ PWMIn3: digital input, idle level high	PWM = 40Hz - 10kHz, characteristics parameterizable	D15A [7]	○	○
	○ PWMIn3: digital input, idle level low	active: pin open or applied voltage 3.5-50VDC not active: applied voltage < 1.5VDC, SELV	D15A [8]	○	○
	○ Aout3 0-10V: analog output	function parameterizable, max. 5mA max output frequency 300Hz SELV	D15A [4]	○	○
RSA	○ Tacho out (pulses), analog output	0-10V/max. 5mA max output frequency 300Hz SELV	D15A [5]	○	○
	○ Diagnostics out (pulses)	0-10V/max. 5mA max output frequency 300Hz, SELV	D15A [6]	○	○
	○ Diagnostics out (pulses)	MODBUS RTU, specification V6.3, SELV			
RSB	RS485 bus connection,				
Vout	voltage output	voltage parameterizable 3.3..24VDC +/- 5%, P _{max} =600mW, short-circuit-proof, supply for external devices, SELV	D16E [..]		
	alternatively: Input auxiliary power supply for parameterization via RS485/MODBUS RTU without line voltage	15..50VDC			

○ configurable option

For further information and additional functions see EC Control Software, Fan-Set-App, or MODBUS Parameter Specification V6.3



Curves: Air performance 50 Hz

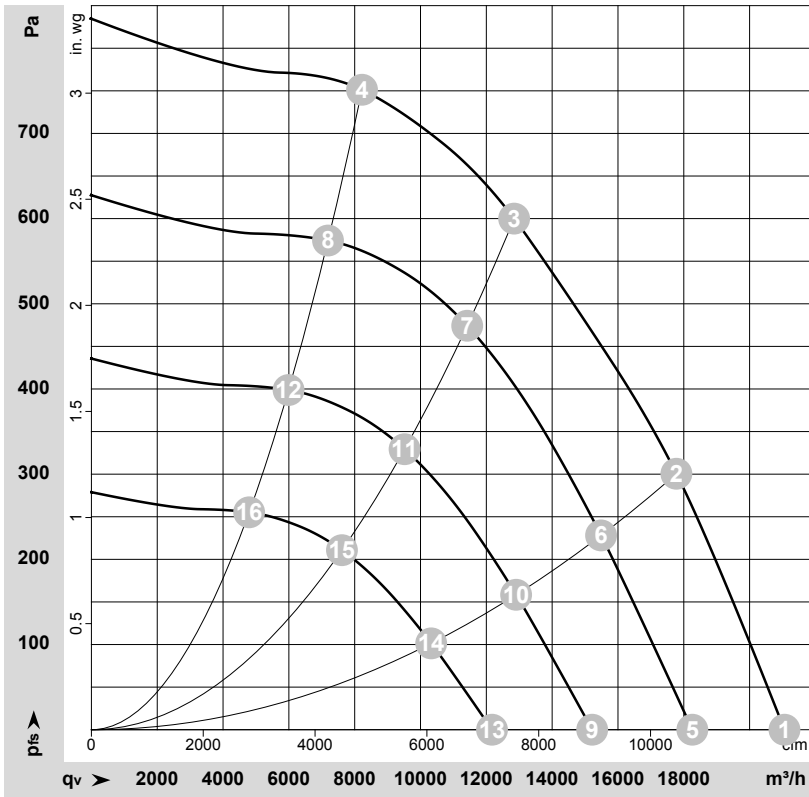

$\rho = 1.15 \text{ kg/m}^3 \pm 2 \%$

Measurement: LU-207135-1

Air performance measured according to ISO 5801 installation category A. For detailed information on the measurement setup, contact ebmpapst. Intake sound level: Sound power level according to ISO 13347 / sound pressure level measured at 1 m distance from fan axis. The values given are valid under the specified measuring conditions and may vary due to conditions of installation. For deviations from the standard configuration, the parameters have to be checked on the installed unit.

Measured values

	Wired	U	f	n	P _{ed}	I	LpA _{in}	LwA _{in}	LwA _{out}	q _v	p _{fs}	q _v	p _{fs}
		V	Hz	min ⁻¹	W	A	dB(A)	dB(A)	dB(A)	m ³ /h	Pa	cfm	in. wg
1	3~	200	50	1380	2118	6.46	79	86	90	21060	0	12395	0.00
2	3~	200	50	1380	2959	8.97	78	83	87	17775	300	10460	1.20
3	3~	200	50	1380	3250	9.90	68	76	82	12845	600	7560	2.41
4	3~	200	50	1380	3091	9.37	75	83	87	8225	750	4840	3.01
5	3~	200	50	1200	1381	4.21	75	83	87	18260	0	10745	0.00
6	3~	200	50	1200	1952	5.92	74	80	84	15485	229	9115	0.92
7	3~	200	50	1200	2292	6.94	65	73	79	11420	475	6720	1.91
8	3~	200	50	1200	2067	6.26	71	79	83	7190	574	4230	2.30
9	3~	200	50	1000	799	2.44	71	78	82	15215	0	8955	0.00
10	3~	200	50	1000	1130	3.43	70	75	79	12905	159	7595	0.64
11	3~	200	50	1000	1326	4.02	61	69	75	9515	330	5600	1.32
12	3~	200	50	1000	1196	3.62	67	75	79	5990	399	3525	1.60
13	3~	200	50	800	409	1.25	65	73	77	12175	0	7165	0.00
14	3~	200	50	800	578	1.75	64	69	74	10325	102	6075	0.41
15	3~	200	50	800	679	2.06	55	63	69	7615	211	4480	0.85
16	3~	200	50	800	612	1.86	61	69	73	4795	255	2820	1.02

Wired = Wiring · U = Voltage · f = Frequency · n = Speed (rpm) · P_{ed} = Power consumption · I = Current draw · LpA_{in} = Sound pressure level intake side · LwA_{in} = Sound power level intake side · LwA_{out} = Sound power level outlet side · q_v = Air flow · p_{fs} = Pressure increase

