

R3G630-AQ01-01

# EC centrifugal fan

backward-curved, single-intake



R3G630-AQ01-01 ebmpapst Datasheet  
sales@fansco.com  
www.fansco.com

Limited partnership · Headquarters Mulfingen  
Amtsgericht (court of registration) Stuttgart · HRA 590344

General partner Elektrobau Mulfingen GmbH · Headquarters Mulfingen  
Amtsgericht (court of registration) Stuttgart · HRB 590142

## Nominal data

Type	R3G630-AQ01-01	
Motor	M3G200-HF	
Phase		3~
Nominal voltage	VAC	400
Nominal voltage range	VAC	380 .. 480
Frequency	Hz	50/60
Method of obtaining data		ml
Speed (rpm)	min <sup>-1</sup>	1450
Power consumption	W	6140
Current draw	A	9.8
Min. ambient temperature	°C	-25
Max. ambient temperature	°C	50

ml = Max. load · me = Max. efficiency · fa = Free air · cs = Customer specification · ce = Customer equipment  
Subject to change

## Data according to Commission Regulation (EU) 327/2011

		Actual	Req. 2015
01 Overall efficiency $\eta_{es}$	%	65	59.8
02 Measurement category		A	
03 Efficiency category		Static	
04 Efficiency grade N		67.2	62
05 Variable speed drive		Yes	

Data obtained at optimum efficiency level.  
The ErP data is determined using a motor-impeller combination in a standardized measurement setup.

09 Power consumption $P_{ed}$	kW	6.14
09 Air flow $q_v$	m <sup>3</sup> /h	14340
09 Pressure increase $p_{fs}$	Pa	965
10 Speed (rpm) $n$	min <sup>-1</sup>	1455
11 Specific ratio*		1.01

\* Specific ratio =  $1 + p_{fs} / 100\,000\text{ Pa}$

LU-132233



## Technical description

Weight	58 kg
Fan size	630 mm
Rotor surface	Painted black
Electronics housing material	Die-cast aluminum
Impeller material	Sheet aluminum
Number of blades	7
Direction of rotation	Clockwise, viewed toward rotor
Degree of protection	IP54
Insulation class	"F"
Moisture (F) / Environmental (H) protection class	F4-1
Max. permitted ambient temp. for motor (transport/storage)	+80 °C
Min. permitted ambient temp. for motor (transport/storage)	-40 °C
Installation position	Shaft horizontal or rotor on bottom; rotor on top on request
Condensation drainage holes	On rotor side
Mode	S1
Motor bearing	Ball bearing
Technical features	<ul style="list-style-type: none"> <li>- Output 10 VDC, max. 10 mA</li> <li>- Output 20 VDC, max. 50 mA</li> <li>- Output for slave 0-10 V</li> <li>- Input for sensor 0-10 V or 4-20 mA</li> <li>- External 24 V input (parameter setting)</li> <li>- External release input</li> <li>- Alarm relay</li> <li>- Integrated PID controller</li> <li>- Motor current limitation</li> <li>- PFC, passive</li> <li>- RS-485 MODBUS-RTU</li> <li>- Soft start</li> <li>- EEPROM write cycles: 100,000 maximum</li> <li>- Control input 0-10 VDC / PWM</li> <li>- Control interface with SELV potential safely disconnected from the mains</li> <li>- Thermal overload protection for electronics/motor</li> <li>- Line undervoltage / phase failure detection</li> </ul>
Touch current according to IEC 60990 (measuring circuit Fig. 4, TN system)	<= 3.5 mA
Electrical hookup	Via terminal box
Motor protection	Reverse polarity and locked-rotor protection
Protection class	I (with customer connection of protective earth)
Conformity with standards	EN 61800-5-1; CE
Approval	C22.2 No.77 + CAN/CSA-E60730-1; EAC; UL 1004-7 + 60730

Product drawing

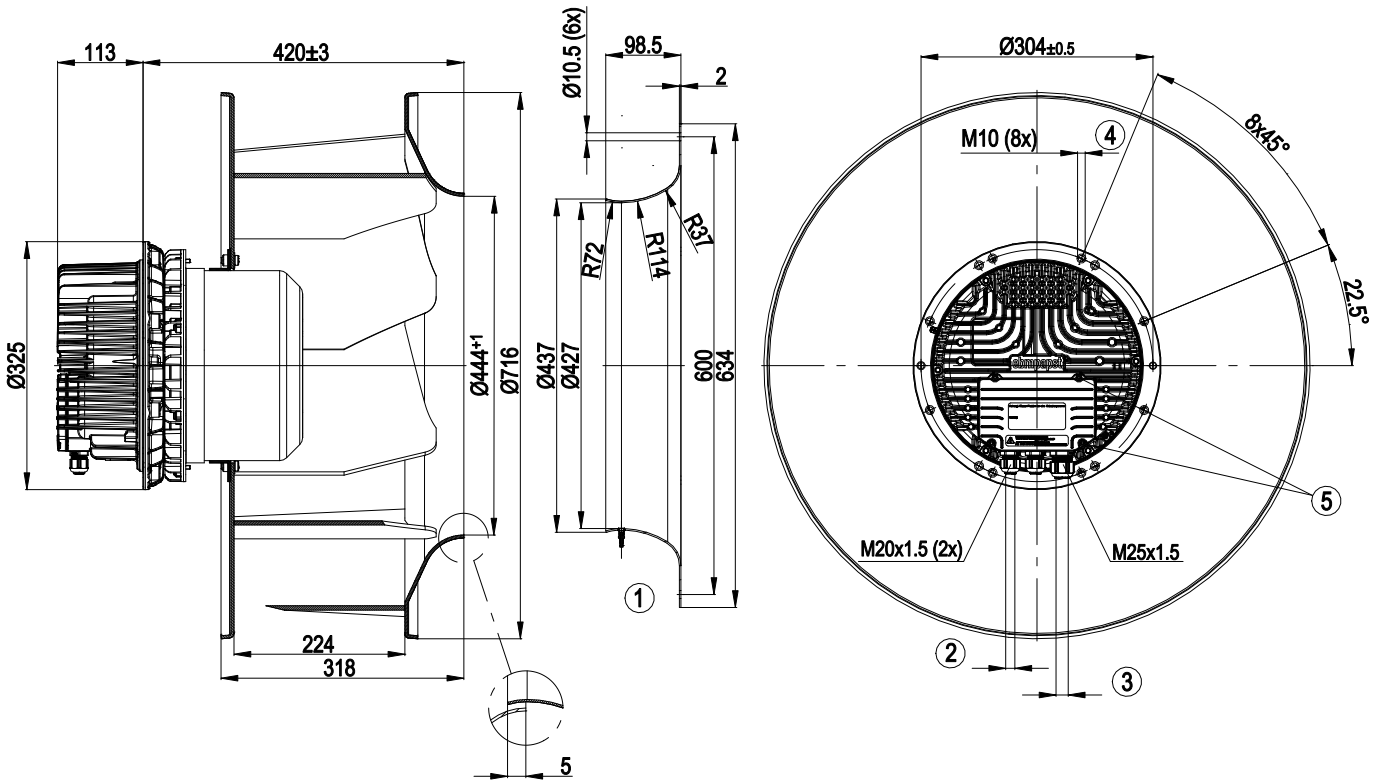

1	Accessory part: Inlet ring 64040-2-4013 with pressure tap not included in scope of delivery
2	Cable diameter min. 4 mm, max. 10 mm, tightening torque 4 ± 0.6 Nm
3	Cable diameter min. 9 mm, max. 16 mm, tightening torque 6 ± 0.9 Nm
4	Max. clearance for screw 25 mm
5	Tightening torque 3.5 ± 0.5 Nm



## Connection diagram

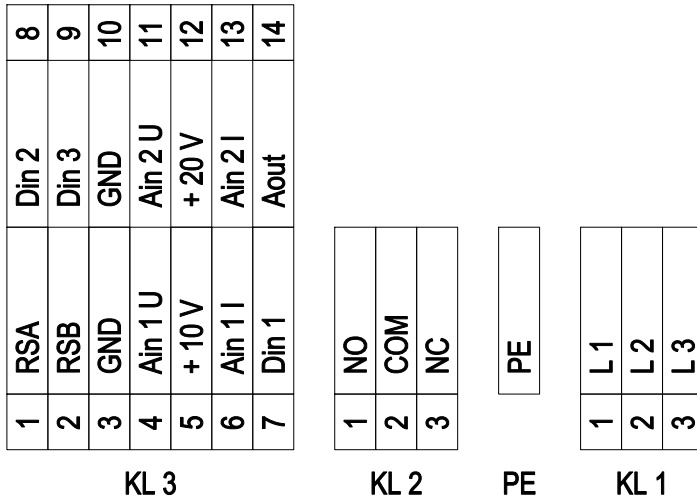

No.	Conn.	Designation	Function/assignment
KL 1	1	L1	Supply connection, power supply 3-phase 380-480 VAC, 50/60 Hz
KL 1	2	L2	Supply connection, power supply 3-phase 380-480 VAC, 50/60 Hz
KL 1	3	L3	Supply connection, power supply 3-phase 380-480 VAC, 50/60 Hz
PE		PE	Ground connection, PE connection
KL 2	1	NO	Status relay, floating status contact; make for failure
KL2	2	COM	Status relay, floating status contact; changeover contact; common connection; contact rating 250 VAC / max. 2 A (AC1) / min. 10 mA
KL2	3	NC	Status relay, floating status contact; break for failure
KL 3	1	RSA	Bus connection RS485, RSA, MODBUS-RTU; SELV
KL 3	2	RSB	Bus connection RS485, RSB, MODBUS-RTU; SELV
KL 3	3 / 10	GND	Reference ground for control interface; SELV
KL 3	4	Ain1 U	Analog input 1, set value: 0-10 V, Ri = 100 kΩ, adjustable curve, only usable as alternative to input Ain1 I; SELV
KL 3	5	+ 10 V	Fixed voltage output 10 VDC, +10 V ±3%, max. 10 mA, short-circuit-proof power supply for external devices (e.g. pot); SELV
KL 3	6	Ain1 I	Analog input 1, set value: 4-20 mA, Ri = 100 Ω, adjustable curve, only usable as alternative to input Ain1U; SELV
KL 3	7	Din1	Digital input 1: enable electronics, enable: pin open or applied voltage 5-50 VDC disable: bridge to GND or applied voltage < 1 VDC reset function: triggers software reset after a level change to < 1 VDC; SELV
KL 3	8	Din2	Digital input 2: Switching parameter sets 1/2, according to EEPROM setting, the valid or used parameter set can be selected via bus or via digital input DIN2. Parameter set 1: pin open or applied voltage 5-50 VDC Parameter set 2: bridge to GND or applied voltage < 1 VDC; SELV
KL 3	9	Din3	Digital input 3: according to EEPROM setting, the integrated controller's direction of action can be selected as normal/inverse via bus or digital input normal: pin open or applied voltage 5-50 VDC inverse: bridge to GND or applied voltage < 1 VDC; SELV
KL 3	11	Ain2 U	Analog input 2, measured value: 0-10 V, Ri = 100 kΩ, adjustable curve, only usable as alternative to input Ain2I; SELV
KL 3	12	+ 20 V	Fixed voltage output 20 VDC, +20 V ±5/-10%, max. 50 mA, short-circuit-proof power supply for external devices (e.g. sensors); SELV

# EC centrifugal fan

backward-curved, single-intake

No.	Conn.	Designation	Function/assignment
KL 3	13	Ain2 I	Analog input 2, measured value: 4-20 mA, Ri = 100 Ω, adjustable curve, only usable as alternative to input Ain2U; SELV
KL 3	14	Aout	Analog output 0-10 VDC, max. 5 mA, output of current motor modulation level / motor speed adjustable curve; SELV



## Curves: Air performance 50 Hz

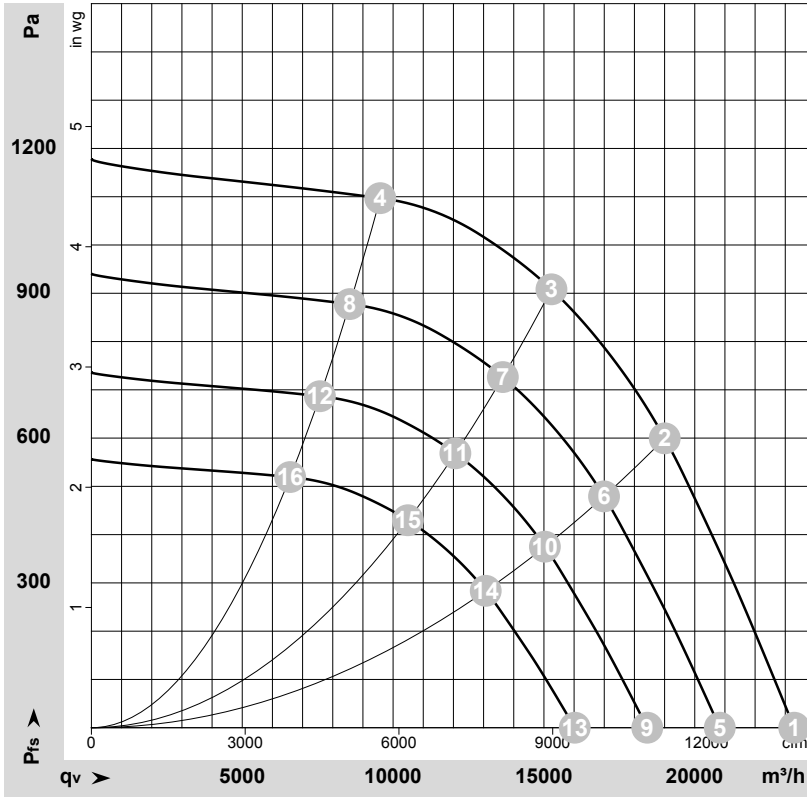

$\rho = 1.15 \text{ kg/m}^3 \pm 2 \%$

Measurement: LU-132233-1

Air performance measured according to ISO 5801 installation category A. For detailed information on the measurement setup, contact ebmpapst. Intake sound level: Sound power level according to ISO 13347 / sound pressure level measured at 1 m distance from fan axis. The values given are valid under the specified measuring conditions and may vary due to conditions of installation. For deviations from the standard configuration, the parameters have to be checked on the installed unit.

## Measured values

	U	f	n	P <sub>ed</sub>	I	LpA <sub>in</sub>	LwA <sub>in</sub>	LwA <sub>out</sub>	q <sub>v</sub>	P <sub>fs</sub>	q <sub>v</sub>	P <sub>fs</sub>
	V	Hz	min <sup>-1</sup>	W	A	dB(A)	dB(A)	dB(A)	m <sup>3</sup> /h	Pa	cfm	inH <sub>2</sub> O
1	400	50	1450	4114	6.74	86	95	101	23295	0	13710	0.00
2	400	50	1450	5762	9.20	78	87	95	19005	600	11185	2.41
3	400	50	1450	6140	9.80	76	84	94	15250	900	8975	3.61
4	400	50	1450	5296	8.50	78	86	95	9575	1100	5635	4.42
5	400	50	1300	2940	4.82	83	92	98	20830	0	12260	0.00
6	400	50	1300	4118	6.58	76	84	92	16995	484	10000	1.94
7	400	50	1300	4408	7.07	73	82	91	13640	727	8025	2.92
8	400	50	1300	3789	6.08	75	83	92	8565	878	5040	3.52
9	400	50	1150	2035	3.34	80	89	95	18425	0	10845	0.00
10	400	50	1150	2851	4.55	72	81	89	15030	379	8850	1.52
11	400	50	1150	3052	4.89	70	79	88	12065	569	7100	2.28
12	400	50	1150	2623	4.21	72	80	89	7575	687	4460	2.76
13	400	50	1000	1338	2.19	76	85	92	16025	0	9430	0.00
14	400	50	1000	1874	2.99	69	78	86	13070	286	7695	1.15
15	400	50	1000	2006	3.22	67	75	84	10490	430	6175	1.73
16	400	50	1000	1725	2.77	69	77	85	6585	519	3875	2.08

U = Power supply · f = Frequency · n = Speed (rpm) · P<sub>ed</sub> = Power consumption · I = Current draw · LpA<sub>in</sub> = Sound pressure level intake side · LwA<sub>in</sub> = Sound power level intake side  
 LwA<sub>out</sub> = Sound power level outlet side · q<sub>v</sub> = Air flow · P<sub>fs</sub> = Pressure increase

