

R3G630-AF35-11

EC centrifugal fan

backward-curved, single-intake



R3G630-AF35-11 ebmpapst Datasheet

sales@fansco.com

www.fansco.com

Limited partnership · Headquarters Muldingen
Amtsgericht (court of registration) Stuttgart · HRA 590344

General partner Elektrobau Muldingen GmbH · Headquarters Muldingen
Amtsgericht (court of registration) Stuttgart · HRB 590142



Nominal data

Type	R3G630-AF35-11	
Motor	M3G112-GA	
Phase		1~
Nominal voltage	VAC	230
Nominal voltage range	VAC	200 .. 277
Frequency	Hz	50/60
Method of obtaining data		ml
Speed (rpm)	min ⁻¹	680
Power consumption	W	545
Current draw	A	2.6
Min. ambient temperature	°C	-25
Max. ambient temperature	°C	40

ml = Max. load · me = Max. efficiency · fa = Free air · cs = Customer specification · ce = Customer equipment
Subject to change

Data according to ErP Directive

		Actual	Req. 2015			
01 Overall efficiency η_{es}	%	56.8	48.7	09 Power consumption P_{ed}	kW	0.54
02 Measurement category		A		09 Air flow q_v	m ³ /h	5980
03 Efficiency category		Static		09 Pressure increase p_{fs}	Pa	169
04 Efficiency grade N		70.1	62	10 Speed (rpm) n	min ⁻¹	685
05 Variable speed drive		Yes		11 Specific ratio*		1.00

Data obtained at optimum efficiency level.

The ErP data is determined using a motor-impeller combination in a standardized measurement setup.

* Specific ratio = $1 + p_{fs} / 100\,000\text{ Pa}$

LU-114139



Technical description

Weight	14.75 kg
Fan size	630 mm
Rotor surface	Painted black
Electronics housing material	Die-cast aluminum
Impeller material	Sheet aluminum
Number of blades	6
Direction of rotation	Clockwise, viewed toward rotor
Degree of protection	IP54
Insulation class	"B"
Moisture (F) / Environmental (H) protection class	F4-1
Max. permitted ambient temp. for motor (transport/storage)	+80 °C
Min. permitted ambient temp. for motor (transport/storage)	-40 °C
Installation position	Shaft horizontal or rotor on bottom; rotor on top on request
Condensation drainage holes	On rotor side
Mode	S1
Motor bearing	Ball bearing
Technical features	<ul style="list-style-type: none"> - Output 10 VDC, max. 10 mA - Output 20 VDC, max. 50 mA - Output for slave 0-10 V - Input for sensor 0-10 V or 4-20 mA - Alarm relay - Integrated PID controller - Motor current limitation - PFC, active - RS-485 ebmBUS - Soft start - Control input 0-10 VDC / PWM - Control interface with SELV potential safely disconnected from supply - Thermal overload protection for electronics/motor - Line undervoltage / phase failure detection
EMC immunity to interference	According to EN 61000-6-2
EMC circuit feedback	According to EN 61000-3-2/3
EMC interference emission	According to EN 55022 (Class A)
Touch current according to IEC 60990 (measuring circuit Fig. 4, TN system)	<= 3.5 mA
Electrical hookup	Via terminal box
Motor protection	Thermal overload protector (TOP) internally connected
With cable	Variable
Protection class	I (with customer connection of protective earth)
Conformity with standards	EN 61800-5-1; CE

Product drawing

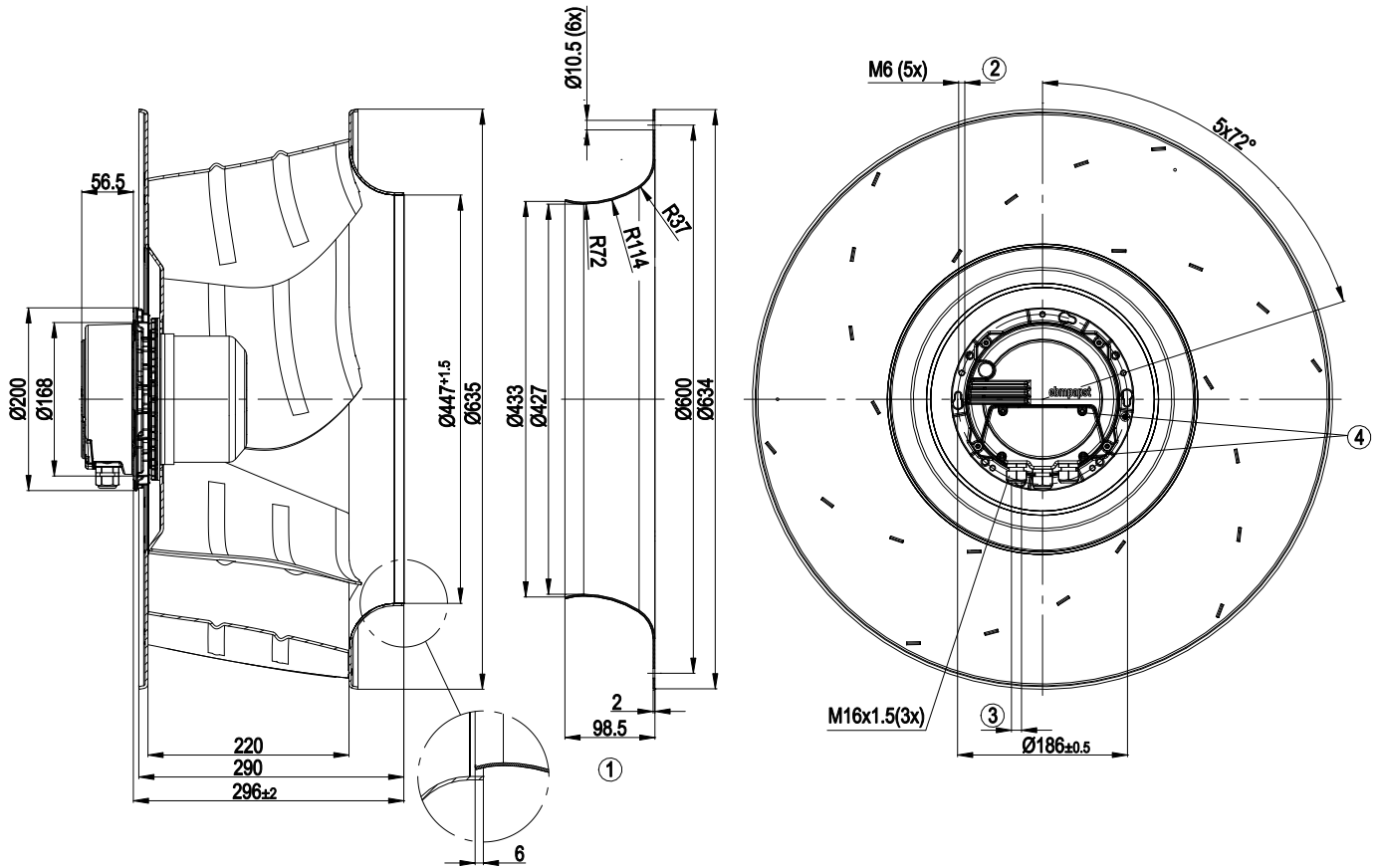

1	Accessory part: inlet ring 63070-2-4013 not included in scope of delivery
2	Max. clearance for screw 16 mm
3	Cable diameter min. 4 mm, max. 10 mm; tightening torque 2.5 ± 0.4 Nm
4	Tightening torque 3.5 ± 0.5 Nm



Connection diagram

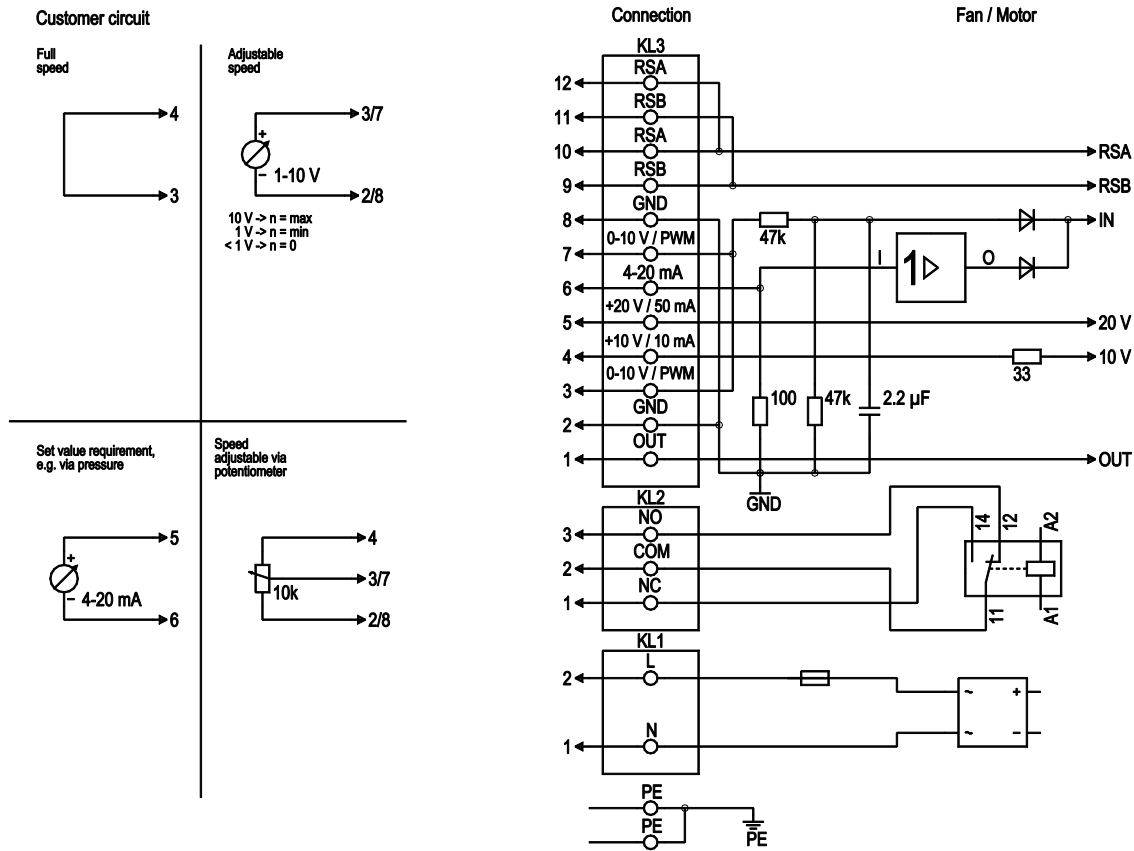

No.	Conn.	Designation	Function/assignment
PE		PE	Protective earth terminal
KL1	1, 2	N, L	Power supply 50/60 Hz
KL2	1	NC	Floating status contact, break for failure
KL2	2	COM	Floating status contact, changeover contact, common connection (2 A, max. 250 VAC, min. 10 mA, AC1)
KL2	3	NO	Floating status contact, make for failure
KL3	1	OUT	Analog output, 0-10 VDC, max. 3 mA, SELV, output of current motor modulation level: 1 V corresponds to 10% modulation level. 10 V corresponds to 100% modulation level.
KL3	2, 8	GND	Reference ground for control interface, SELV
KL3	3, 7	0-10 V	Use control / current sensor value input 0-10 VDC, impedance 100 kΩ only as alternative to 4-20 mA input, SELV
KL3	4	+10 V	Voltage output 10 VDC (±3 %), max. 10 mA, power supply for external devices (e.g. potentiometer), SELV
KL3	5	+20 V	Voltage output 20 VDC (+25% / -10%), max. 50 mA, power supply for external devices (e.g. sensors); SELV
KL3	6	4-20 mA	Use control / current sensor value input 4-20 mA, impedance 100 Ω only as alternative to 0-10 V input, SELV
KL3	9, 11	RSB	RS485 interface for ebmBUS, RSB, SELV
KL3	10, 12	RSA	RS485 interface for ebmBUS, RSA, SELV



Curves: Air performance 50 Hz

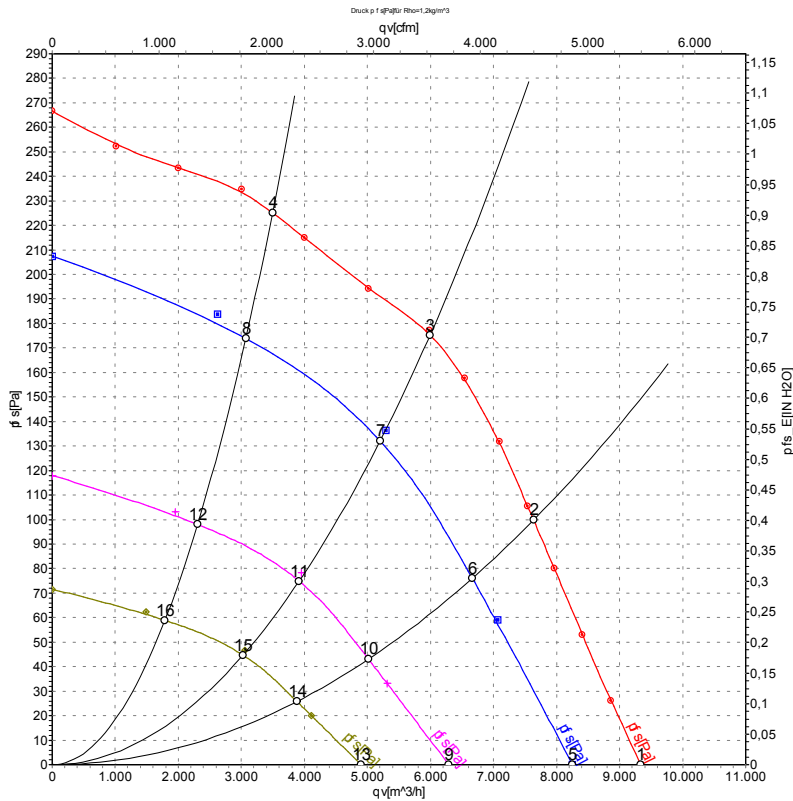

Measurement: LU-114139-1
 Measurement: LU-115127-1
 Measurement: LU-115126-1
 Measurement: LU-115125-1

Air performance measured according to ISO 5801 installation category A. For detailed information on the measurement setup, contact ebm-papst. Intake sound level: Sound power level according to ISO 13347 / sound pressure level measured at 1 m distance from fan axis. The values given are valid under the specified measuring conditions and may vary due to conditions of installation. For deviations from the standard configuration, the parameters have to be checked on the installed unit.

Measured values

	U	f	n	P _{ed}	I	LpA _{in}	LwA _{in}	LwA _{out}	qv	P _{fs}	qv	P _{fs}
	V	Hz	min ⁻¹	W	A	dB(A)	dB(A)	dB(A)	m ³ /h	Pa	CFM	inH2O
1	230	50	680	375	1.73	62	69	74	9335	0	5495	0.00
2	230	50	680	481	2.20	58	66	71	7635	100	4495	0.40
3	230	50	680	545	2.50	57	65	70	5995	175	3530	0.70
4	230	50	680	460	2.11	58	65	71	3495	225	2055	0.90
5	230	50	600	240	1.13	57	65	70	8250	0	4855	0.00
6	230	50	600	308	1.42	54	62	68	6665	76	3920	0.31
7	230	50	600	346	1.60	54	62	67	5200	138	3060	0.55
8	230	50	600	289	1.34	54	62	68	3070	176	1810	0.71
9	230	50	450	109	0.53	50	58	63	6290	0	3705	0.00
10	230	50	450	134	0.64	46	55	60	5015	43	2950	0.17
11	230	50	450	149	0.70	46	54	60	3915	79	2305	0.32
12	230	50	450	128	0.61	46	54	60	2305	99	1355	0.40
13	230	50	350	56	0.36	43	51	57	4900	0	2885	0.00
14	230	50	350	69	0.41	40	48	54	3880	26	2285	0.10
15	230	50	350	78	0.45	40	48	54	3025	47	1780	0.19
16	230	50	350	67	0.40	39	48	53	1785	59	1050	0.24

U = Power supply · f = Frequency · n = Speed (rpm) · P_{ed} = Power consumption · I = Current draw · LpA_{in} = Sound pressure level intake side · LwA_{in} = Sound power level intake side
 LwA_{out} = Sound power level outlet side · qv = Air flow · p_{fs} = Pressure increase

