

R3G630-AB30-20

Emerson

EC centrifugal fan

backward-curved, single-intake



R3G630-AB30-20 ebmpapst Datasheet

sales@fansco.com

www.fansco.com

Limited partnership · Headquarters Muldingen

Amtsgericht (court of registration) Stuttgart · HRA 590344

General partner Elektrobau Muldingen GmbH · Headquarters Muldingen

Amtsgericht (court of registration) Stuttgart · HRB 590142

Nominal data

Type	R3G630-AB30-20	
Motor	M3G150-IF	
Phase		3~
Nominal voltage	VAC	200
Nominal voltage range	VAC	200 .. 240
Frequency	Hz	50/60
Method of obtaining data		ml
Speed (rpm)	min ⁻¹	1230
Power consumption	W	2850
Current draw	A	FLA 9.0
Min. ambient temperature	°C	-25
Max. ambient temperature	°C	40

ml = Max. load · me = Max. efficiency · fa = Free air · cs = Customer specification · ce = Customer equipment
Subject to change



R3G630-AB30-20

Emerson

EC centrifugal fan

backward-curved, single-intake

Technical description

Weight	29.3 kg
Fan size	630 mm
Rotor surface	Painted black
Electronics housing material	Die-cast aluminum
Impeller material	Sheet aluminum
Number of blades	6
Direction of rotation	Clockwise, viewed toward rotor
Degree of protection	IP55
Insulation class	"F"
Moisture (F) / Environmental (H) protection class	F4-1
Max. permitted ambient temp. for motor (transport/storage)	+ 80 °C
Min. permitted ambient temp. for motor (transport/storage)	- 40 °C
Installation position	Shaft horizontal or rotor on bottom
Condensation drainage holes	On rotor side
Mode	S1
Motor bearing	Ball bearing
Technical features	<ul style="list-style-type: none">- Output 10 VDC, max. 10 mA- Output 20 VDC, max. 50 mA- Output for slave 0-10 V- Input for sensor 0-10 V or 4-20 mA- External 24 V input (parameter setting)- External release input- Alarm relay- Integrated PID controller- Motor current limitation- PFC, passive- RS-485 MODBUS-RTU- Soft start- Control input 0-10 VDC / PWM- Control interface with SELV potential safely disconnected from the mains- Thermal overload protection for electronics/motor- Line undervoltage / phase failure detection
Touch current according to IEC 60990 (measuring circuit Fig. 4, TN system)	<= 3.5 mA
Electrical hookup	Via terminal box
Motor protection	Reverse polarity and locked-rotor protection
Protection class	I (with customer connection of protective earth)
Conformity with standards	EN 61800-5-1
Approval	C22.2 No.77 + CAN/CSA-E60730-1; EAC; UL 1004-7 + 60730



R3G630-AB30-20

Emerson

EC centrifugal fan

backward-curved, single-intake

Product drawing

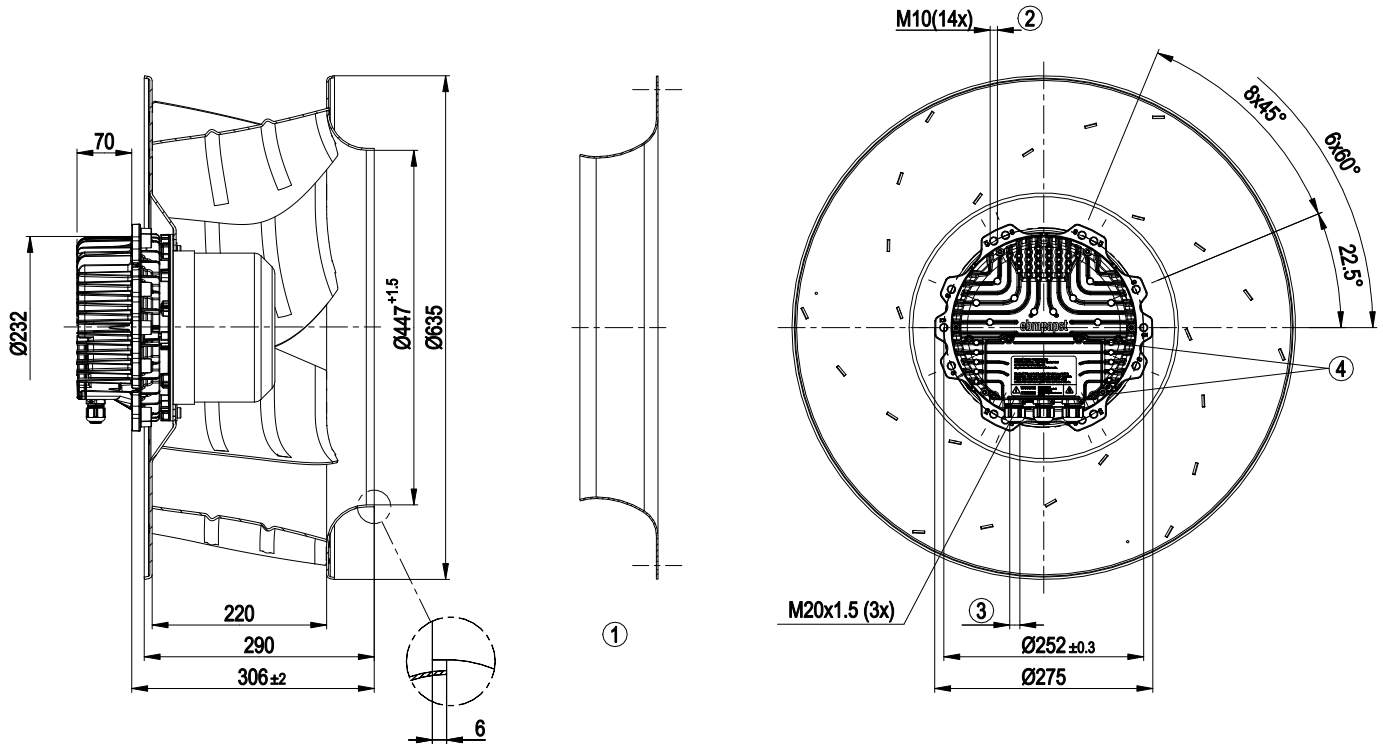

1	Accessory part: inlet ring 63070-2-4013 not included in scope of delivery
2	Max. clearance for screw 25 mm
3	Cable diameter min. 4 mm, max. 10 mm, tightening torque 4 ± 0.6 Nm
4	Tightening torque 3 ± 0.5 Nm



R3G630-AB30-20

Emerson

EC centrifugal fan

backward-curved, single-intake

Accessory part

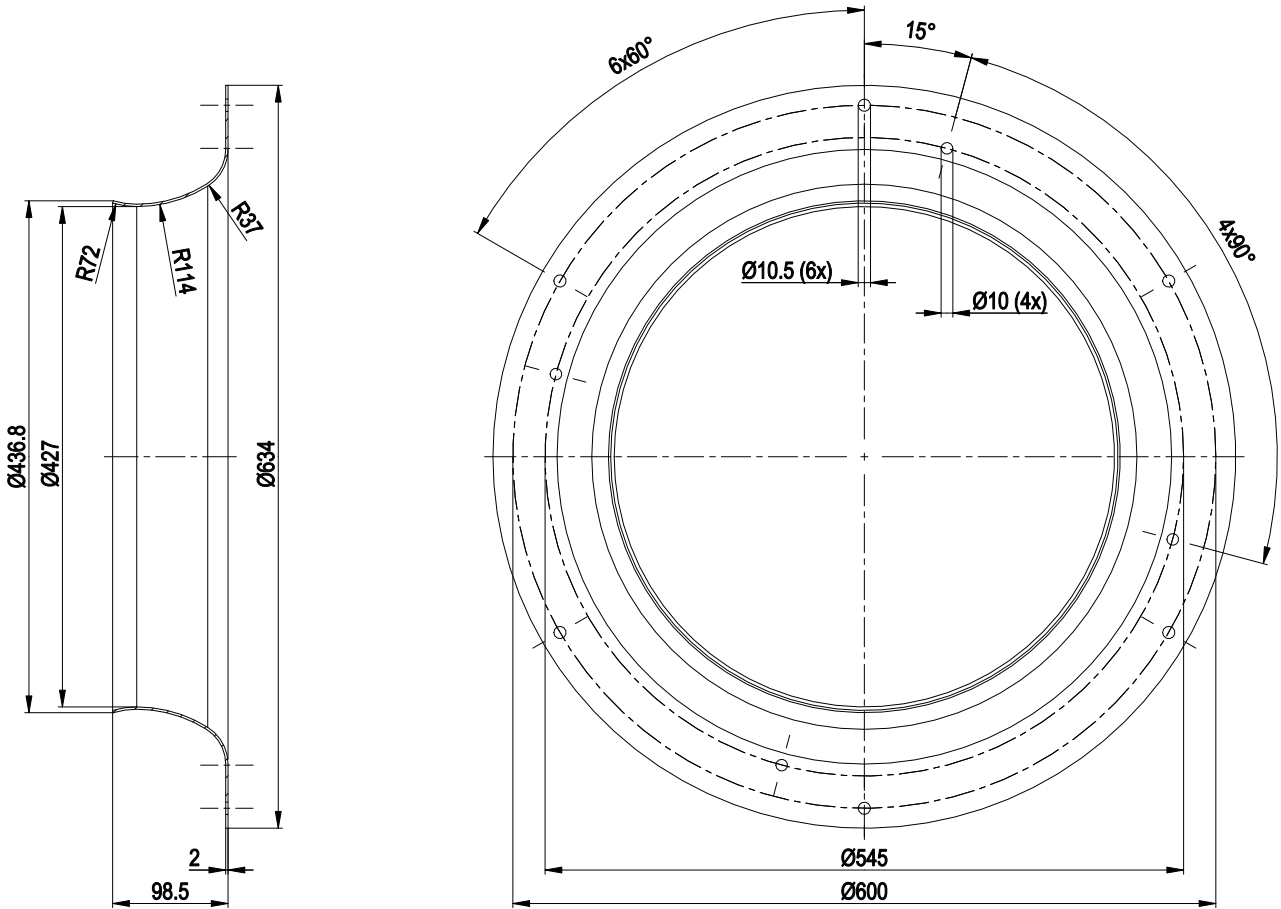

Inlet ring 63070-2-4013 not included in scope of delivery



R3G630-AB30-20

Emerson

EC centrifugal fan

backward-curved, single-intake

No.	Conn.	Designation	Function/assignment
KL 3	13	Ain2 I	Analog input 2, measured value: 4-20 mA, Ri = 100 Ω, adjustable curve, only usable as alternative to input Ain2U; SELV
KL 3	14	Aout	Analog output 0-10 VDC, max. 5 mA, output of current motor modulation level / motor speed adjustable curve; SELV



Curves: Air performance 50 Hz

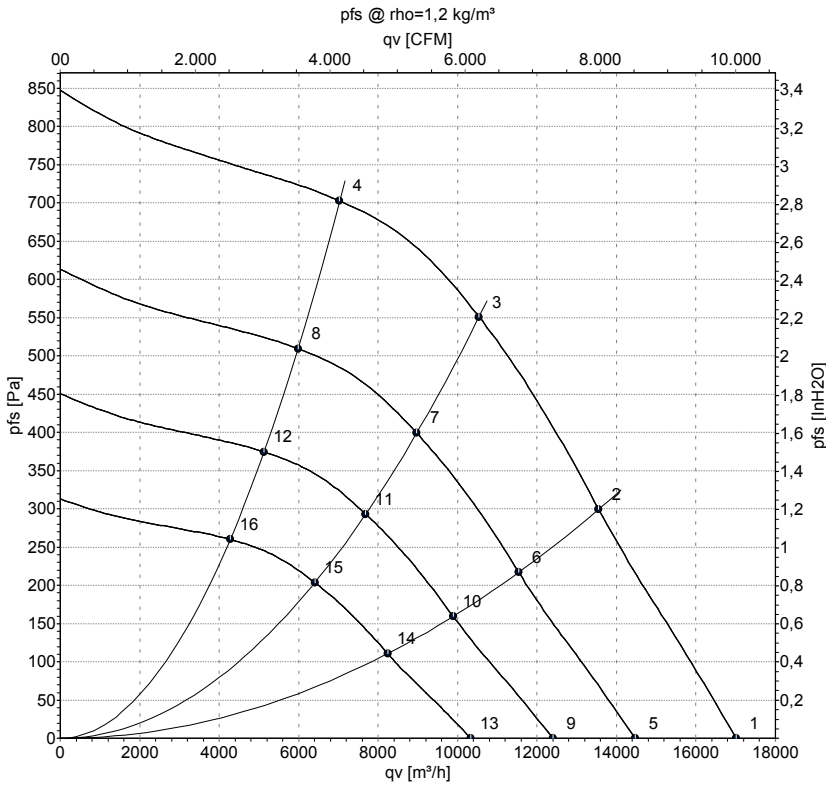

Measurement: LU-154787-1

Air performance measured according to ISO 5801 installation category A. For detailed information on the measurement setup, contact ebmpapst. Intake sound level: Sound power level according to ISO 13347 / sound pressure level measured at 1 m distance from fan axis. The values given are valid under the specified measuring conditions and may vary due to conditions of installation. For deviations from the standard configuration, the parameters have to be checked on the installed unit.

Measured values

	Wired	U	f	n	P _{ed}	I	LpA _{in}	LwA _{in}	LwA _{out}	qv	p _{fs}	qv	p _{fs}
		V	Hz	min ⁻¹	W	A	dB(A)	dB(A)	dB(A)	m ³ /h	Pa	CFM	inH2O
1	Y	200	50	1230	1996	6.44	77	84	90	17020	0	10020	0.00
2	Y	200	50	1230	2540	8.08	73	81	87	13555	300	7980	1.20
3	Y	200	50	1230	2850	9.00	71	80	87	10540	550	6205	2.21
4	Y	200	50	1230	2535	8.01	71	80	86	7030	700	4140	2.81
5	Y	200	50	1050	1227	3.96	73	80	85	14470	0	8515	0.00
6	Y	200	50	1050	1566	4.98	69	77	83	11535	217	6790	0.87
7	Y	200	50	1050	1763	5.57	67	76	83	8970	400	5280	1.61
8	Y	200	50	1050	1565	4.94	67	76	82	5985	510	3525	2.05
9	Y	200	50	900	772	2.49	69	76	82	12405	0	7300	0.00
10	Y	200	50	900	986	3.14	65	73	79	9890	159	5820	0.64
11	Y	200	50	900	1110	3.51	63	72	79	7690	294	4525	1.18
12	Y	200	50	900	985	3.11	63	72	78	5130	375	3020	1.51
13	Y	200	50	750	447	1.44	64	72	77	10335	0	6085	0.00
14	Y	200	50	750	571	1.81	61	69	75	8240	110	4850	0.44
15	Y	200	50	750	643	2.03	59	67	74	6410	204	3770	0.82
16	Y	200	50	750	570	1.80	59	67	74	4275	260	2515	1.04

Wired = Wiring · U = Power supply · f = Frequency · n = Speed (rpm) · P_{ed} = Power consumption · I = Current draw · LpA_{in} = Sound pressure level intake side · LwA_{in} = Sound power level intake side
 LwA_{out} = Sound power level outlet side · qv = Air flow · p_{fs} = Pressure increase

