

# EC centrifugal fan

backward curved, single inlet



R3G630-AB21-08 ebmpapst Datasheet

sales@fansco.com

www.fansco.com

Limited partnership · Headquarters Mulfingen  
County court Stuttgart · HRA 590344

General partner Elektrobau Mulfingen GmbH · Headquarters Mulfingen  
County court Stuttgart · HRB 590142



## Nominal data

|                          |                   |            |
|--------------------------|-------------------|------------|
| Type                     | R3G630-AB21-08    |            |
| Motor                    | M3G150-IF         |            |
| Phase                    |                   | 3~         |
| Nominal voltage          | VAC               | 400        |
| Nominal voltage range    | VAC               | 380 .. 480 |
| Frequency                | Hz                | 50/60      |
| Type of data definition  |                   | ml         |
| Speed                    | min <sup>-1</sup> | 1230       |
| Power input              | W                 | 2770       |
| Current draw             | A                 | 4.3        |
| Min. ambient temperature | °C                | -25        |
| Max. ambient temperature | °C                | 55         |

ml = max. load · me = max. efficiency · fa = running at free air · cs = customer specs · cu = customer unit  
Subject to alterations

## Data according to ErP directive

|                       |        |
|-----------------------|--------|
| Installation category | A      |
| Efficiency category   | Static |
| Variable speed drive  | Yes    |
| Specific ratio*       | 1.01   |

\* Specific ratio =  $1 + p_{fs} / 100\,000\text{ Pa}$

|                                |                   | Actual | Request 2013 | Request 2015 |
|--------------------------------|-------------------|--------|--------------|--------------|
| Overall efficiency $\eta_{es}$ |                   | 60.3   | 52.1         | 56.1         |
| Efficiency grade N             |                   | 66.2   | 58           | 62           |
| Power input $P_{ed}$           | kW                | 2.75   |              |              |
| Air flow $q_v$                 | m <sup>3</sup> /h | 8315   |              |              |
| Pressure increase $p_{fs}$     | Pa                | 682    |              |              |
| Speed n                        | min <sup>-1</sup> | 1245   |              |              |

Data established at point of optimum efficiency



### Technical features

|  |   |
|--|---|
| Mass   | 30.5 kg   |
| Size   | 630 mm  |
| Surface of rotor   | Coated in black   |
| Material of electronics housing                                    | Die-cast aluminium  |
| Material of impeller   | Aluminium sheet   |
| Number of blades   | 6   |
| Direction of rotation  | Clockwise, seen on rotor  |
| Type of protection   | IP 54   |
| Insulation class   | "F"   |
| Humidity class   | F4-1  |
| Max. permissible ambient motor temp. (transp./ storage)            | + 80 °C   |
| Min. permissible ambient motor temp. (transp./storage)             | - 40 °C   |
| Mounting position  | Shaft horizontal or rotor on bottom; rotor on top on request  |
| Condensate discharge holes   | Rotor-side  |
| Operation mode   | S1  |
| Motor bearing  | Ball bearing  |
| Technical features   | <ul style="list-style-type: none"> <li>- Output 10 VDC, max. 10 mA</li> <li>- Output 20 VDC, max. 50 mA</li> <li>- Output for slave 0-10 V</li> <li>- Operation and alarm display</li> <li>- Input for sensor 0-10 V or 4-20 mA</li> <li>- External 24 V input (programming)</li> <li>- External release input</li> <li>- Alarm relay</li> <li>- Integrated PID controller</li> <li>- Motor current limit</li> <li>- PFC, passive</li> <li>- RS485 MODBUS RTU</li> <li>- Soft start</li> <li>- Control input 0-10 VDC / PWM</li> <li>- Over-temperature protected electronics / motor</li> <li>- Line undervoltage / phase failure detection</li> </ul> |
| EMC interference immunity  | Acc. to EN 61000-6-2 (industrial environment)   |
| EMC interference emission  | Acc. to EN 61000-6-3 (household environment)  |
| Touch current acc. IEC 60990 (measuring network Fig. 4, TN system) | <= 3.5 mA   |
| Electrical leads   | With plug   |
| Motor protection   | Reverse polarity and locked-rotor protection  |
| Cable exit   | Lateral   |
| Protection class   | I (if protective earth is connected by customer)  |
| Product conforming to standard                                     | EN 61800-5-1; CE  |
| Approval   | GOST  |

## Product drawing

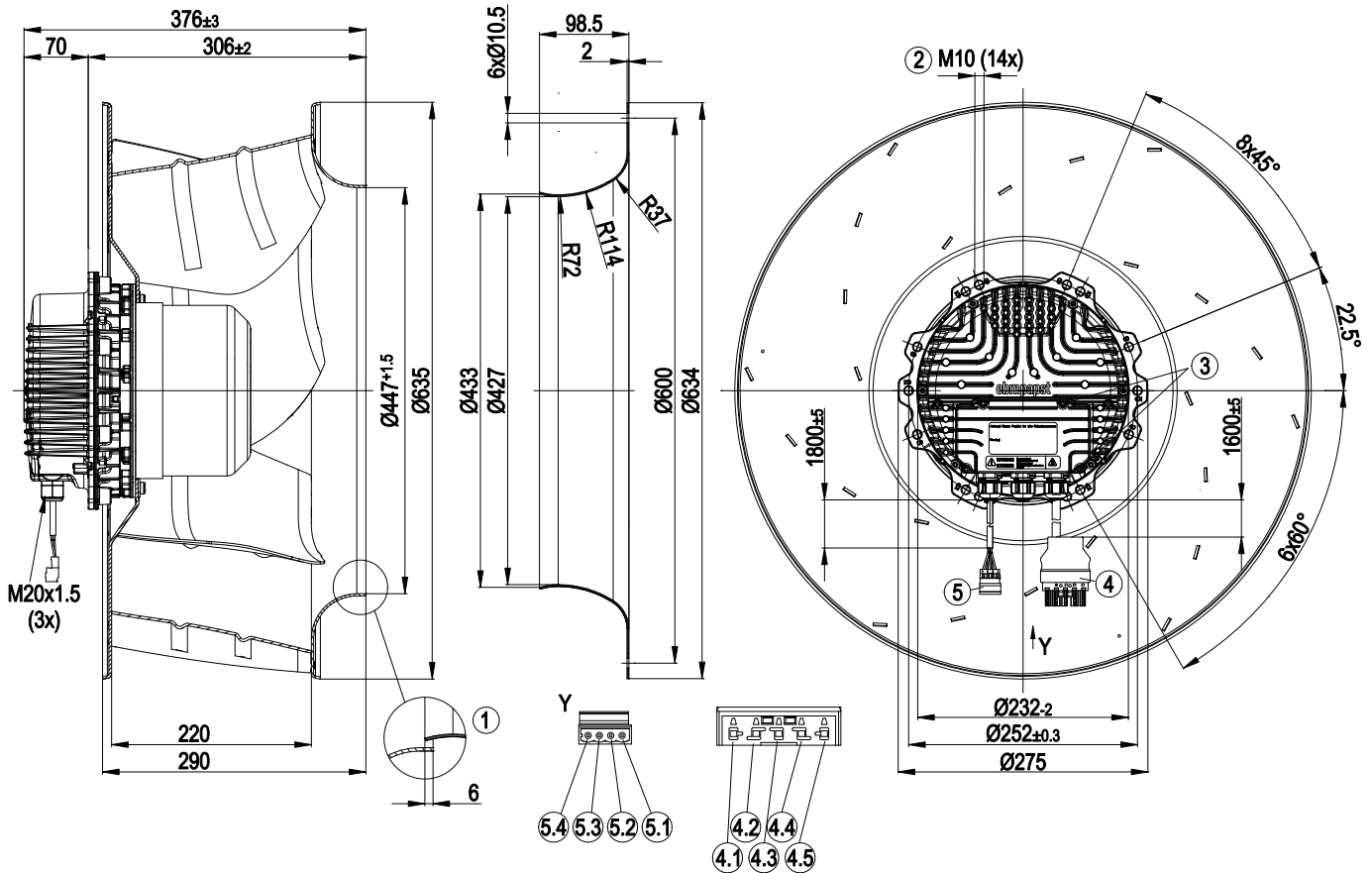

|     |   |
|-----|---|
| 1   | Accessory part: inlet nozzle 63070-2-4013 not included in the standard scope of delivery; other inlet nozzles on request                                |
| 2   | Depth of screw max. 25 mm   |
| 3   | Tightening torque 3.5±0.5 Nm  |
| Y   | View Y  |
| 4   | Plug, WAGO No. 0770-001/K011-0174/0000-0300, mating connector (not included in delivery), connection line Ölflex Classic 110 grey 4G2.5 m. GNYE         |
| 4.1 | Not assigned  |
| 4.2 | PE  |
| 4.3 | L1  |
| 4.4 | L2  |
| 4.5 | L3  |
| 5   | Strip, 4-pole contact spacing 5 WAGO No. 231-604, mating connector (not included in delivery), connection line Ölflex Classic 110 grey 4 x 0.75 o. GNYE |
| 5.1 | GND   |
| 5.2 | 0 - 10 V / PWM  |
| 5.3 | COM   |
| 5.4 | NC  |

# EC centrifugal fan

backward curved, single inlet

## Connection screen

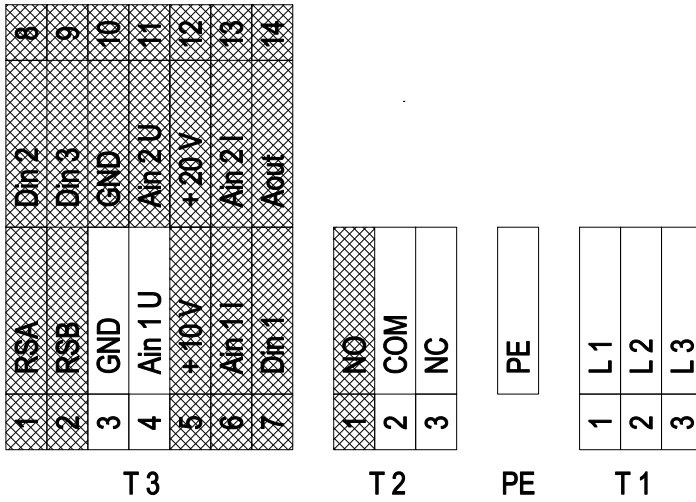

grey shaded => not brought out via leads

| No.  | Pin    | Signal | Function / assignment   |
|------|--------|--------|---|
| KL 1 | 1      | L1     | Mains supply connection, supply voltage 3~380-480 VAC; 50/60 Hz   |
| KL 1 | 2      | L2     | Mains supply connection, supply voltage 3~380-480 VAC; 50/60 Hz   |
| KL 1 | 3      | L3     | Mains supply connection, supply voltage 3~380-480 VAC; 50/60 Hz   |
| PE   |        | PE     | Earth connection, PE connection   |
| KL 2 | 1      | NO     | Status relay, floating status contact; normally open; close with error  |
| KL 2 | 2      | COM    | Status relay; floating status contact; changeover contact; common connection; contact rating 250 VAC / 2 A (AC1)  |
| KL 2 | 3      | NC     | Status relay, floating status contact; normally closed; opens with error  |
| KL 3 | 1      | RSA    | Bus connection RS485; RSA; MODBUS RTU   |
| KL 3 | 2      | RSB    | Bus connection RS485; RSB; MODBUS RTU   |
| KL 3 | 3 / 10 | GND    | Signal ground for control interface   |
| KL 3 | 4      | Ain1 U | Analogue input 1 (set value); 0-10 V; Ri= 100 kΩ; parametrisable curve; only usable as alternative to input Ain1 I  |
| KL 3 | 5      | + 10 V | Fixed voltage output 10 VDC; +10 V +/-3 %; max. 10 mA; short circuit proof; power supply for ext. devices (e.g. potentiometer)  |
| KL 3 | 6      | Ain1 I | Analogue input 1 (set value); 4-20 mA; Ri= 100 Ω; parametrisable curve; only usable as alternative to input Ain1 U  |
| KL 3 | 7      | Din1   | Digital input 1: enabling of electronics; enabling: open pin or applied voltage 5 to 50 VDC; disabling: bridge to GND or applied voltage < 1 VDC; reset function: triggers software reset after a level change to <1 V  |
| KL 3 | 8      | Din2   | Digital input 2: parameter set switch 1/2; according to EEPROM setting, the valid/used parameter set is selectable per BUS or per digital input DIN2. Parameter set 1: open pin or applied voltage 5 to 50 VDC; parameter set 2: bridge to GND or applied voltage < 1 VDC   |
| KL 3 | 9      | Din3   | Digital input 3: Control characteristic of the integrated controller; according to EEPROM setting, the control characteristic of the integrated controller is normally/inversely selectable per BUS or per digital input; normal: open pin or applied voltage 5 to 50 VDC (control deviation = actual sensor value - set value) inverse: bridge to GND or applied voltage < 1 VDC (control deviation = set value - actual sensor value) |
| KL 3 | 11     | Ain2 U | Analogue input 2 (actual sensor value); 0-10 V; Ri= 100 kΩ; parametrisable curve; only usable as alternative to input Ain2 I  |
| KL 3 | 12     | + 20 V | Fixed voltage output 20 VDC; +20 V +/-10 %; max. 50 mA; short circuit proof; power supply for ext. devices (e.g. sensors)   |
| KL 3 | 13     | Ain2 I | Analogue input 2 (actual sensor value) 4-20 mA; Ri= 100 Ω; parametrisable curve; only usable as alternative to input Ain2 U   |



# EC centrifugal fan

backward curved, single inlet

| No.  | Pin | Signal | Function / assignment  |
|------|-----|--------|--|
| KL 3 | 14  | Aout   | Analogue output 0-10 V; max. 5 mA; output of the actual motor control factor (output voltage of electronics)/ of the actual motor speed. Parametrisable curve. |



## Charts: Air flow 50 Hz

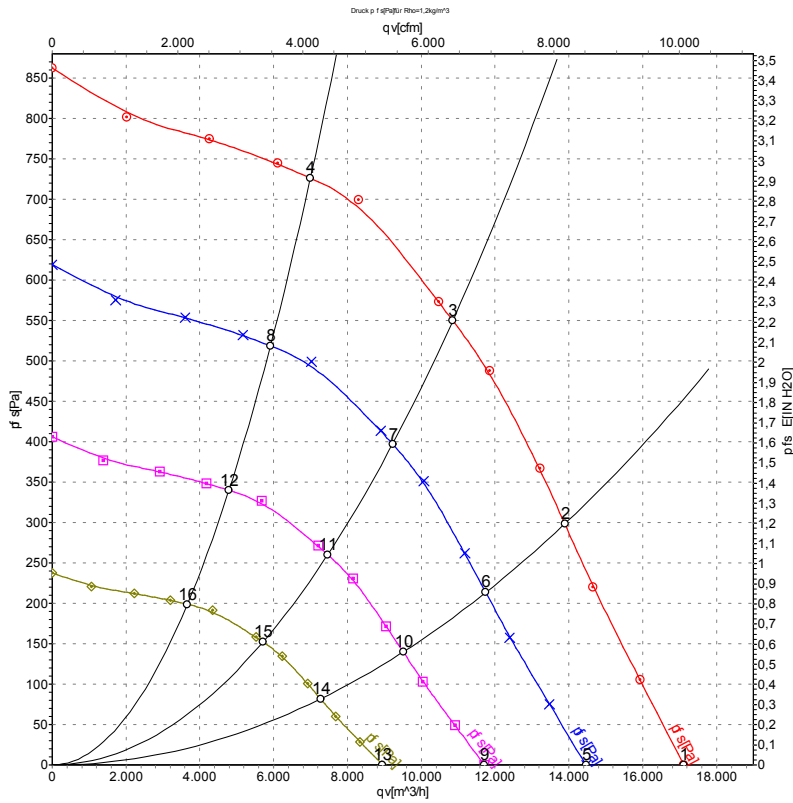

Measurement: LU-132496

Air performance measured as per ISO 5801 Installation category A. For detailed information on the measuring set-up, please contact ebmpapst. Suction-side noise levels: LwA measured as per ISO 13347 / LpA measured with 1m distance to fan axis. The values given are valid under the measuring conditions mentioned above and may vary according to the actual installation situation. With any deviation from the standard set-up, the specific values have to be checked and reviewed with the unit installed.

## Measured values

|    | Conn. | U   | f  | n                 | P <sub>ed</sub> | I    | LpA <sub>in</sub> | LwA <sub>in</sub> | LwA <sub>out</sub> | qv    | p <sub>fs</sub> |
|----|-------|-----|----|-------------------|-----------------|------|-------------------|-------------------|--------------------|-------|-----------------|
|    |       | V   | Hz | min <sup>-1</sup> | W               | A    | dB(A)             | dB(A)             | dB(A)              | m³/h  | Pa              |
| 1  | Y     | 400 | 50 | 1230              | 2052            | 3.42 | 78                | 85                | 91                 | 17120 | 0               |
| 2  | Y     | 400 | 50 | 1230              | 2593            | 4.24 | 73                | 82                | 87                 | 13890 | 300             |
| 3  | Y     | 400 | 50 | 1230              | 2770            | 4.30 | 72                | 80                | 86                 | 10850 | 550             |
| 4  | Y     | 400 | 50 | 1230              | 2581            | 4.21 | 72                | 81                | 86                 | 7000  | 725             |
| 5  | Y     | 400 | 50 | 1050              | 1237            | 2.06 | 74                | 82                | 87                 | 14460 | 0               |
| 6  | Y     | 400 | 50 | 1050              | 1569            | 2.56 | 70                | 78                | 84                 | 11750 | 214             |
| 7  | Y     | 400 | 50 | 1050              | 1779            | 2.89 | 68                | 77                | 83                 | 9225  | 397             |
| 8  | Y     | 400 | 50 | 1050              | 1558            | 2.54 | 69                | 77                | 83                 | 5915  | 519             |
| 9  | Y     | 400 | 50 | 850               | 656             | 1.09 | 69                | 77                | 82                 | 11710 | 0               |
| 10 | Y     | 400 | 50 | 850               | 832             | 1.36 | 65                | 73                | 79                 | 9510  | 140             |
| 11 | Y     | 400 | 50 | 850               | 944             | 1.53 | 63                | 72                | 78                 | 7465  | 260             |
| 12 | Y     | 400 | 50 | 850               | 827             | 1.35 | 64                | 72                | 78                 | 4790  | 340             |
| 13 | Y     | 400 | 50 | 650               | 293             | 0.49 | 64                | 71                | 77                 | 8950  | 0               |
| 14 | Y     | 400 | 50 | 650               | 372             | 0.61 | 59                | 67                | 73                 | 7270  | 82              |
| 15 | Y     | 400 | 50 | 650               | 422             | 0.69 | 58                | 66                | 72                 | 5710  | 152             |
| 16 | Y     | 400 | 50 | 650               | 370             | 0.60 | 58                | 66                | 72                 | 3660  | 199             |

Conn. = Connection · U = Supply voltage · f = Frequency · n = Speed · P<sub>ed</sub> = Power input · I = Current draw · LpA<sub>in</sub> = Sound pressure level inlet side · LwA<sub>in</sub> = Sound power level inlet side · LwA<sub>out</sub> = Sound power level outlet side · qv = Air flow · p<sub>fs</sub> = Pressure increase

