

R3G630-AB06-61

EC centrifugal fan

backward curved, single inlet



R3G630-AB06-61 ebmpapst Datasheet FansCo

sales@fansco.com

www.fansco.com

Nominal data

Type	R3G630-AB06-61	
Motor	M3G150-IF	
Phase		3~
Nominal voltage	VAC	400
Nominal voltage range	VAC	380 .. 480
Frequency	Hz	50/60
Type of data definition		ml
Speed (rpm)	min ⁻¹	1200
Power input	W	2800
Current draw	A	4.2
Min. ambient temperature	°C	-25
Max. ambient temperature	°C	50

ml = Max. load · me = Max. efficiency · fa = Running at free air · cs = Customer specs · cu = Customer unit
Subject to alterations

Data according to ErP directive

		Actual	Request 2015
01 Overall efficiency η_{es}	%	57.9	56.2
02 Measurement category		A	
03 Efficiency category		Static	
04 Efficiency grade N		63.7	62
05 Variable speed drive		Yes	

Data definition with optimum efficiency.

The ErP data is determined using a motor-impeller combination in a standardised measurement configuration.

09 Power input P_{ed}	kW	2.81
09 Air flow q_v	m ³ /h	10005
09 Pressure increase p_{fs}	Pa	555
10 Speed (rpm) n	min ⁻¹	1210
11 Specific ratio*		1.01

* Specific ratio = $1 + p_{fs} / 100\,000\text{ Pa}$

LU-109182



Technical features

Mass	27.7 kg
Size	630 mm
Surface of rotor	Coated in black
Material of electronics housing	Die-cast aluminium
Material of impeller	Aluminium sheet
Number of blades	6
Direction of rotation	Clockwise, seen on rotor
Type of protection	IP 55
Insulation class	"F"
Humidity (F)/environmental protection class (H)	F4-1
Max. permissible ambient motor temp. (transp./ storage)	+80 °C
Min. permissible ambient motor temp. (transp./storage)	-40 °C
Mounting position	Shaft horizontal or rotor on bottom; rotor on top on request
Condensate discharge holes	Rotor-side
Operation mode	S1
Motor bearing	Ball bearing
Technical features	<ul style="list-style-type: none"> - Output 10 VDC, max. 10 mA - Output 20 VDC, max. 50 mA - Output for slave 0-10 V - Input for sensor 0-10 V or 4-20 mA - Alarm relay - Integrated PID controller - Motor current limit - PFC, passive - RS485 ebmBUS - Soft start - Control input 0-10 VDC / PWM - Control interface with SELV potential safely disconnected from the mains - Over-temperature protected electronics / motor - Line undervoltage / phase failure detection
Touch current acc. IEC 60990 (measuring network Fig. 4, TN system)	<= 3.5 mA
Electrical leads	Via terminal box
Motor protection	Reverse polarity and locked-rotor protection
Protection class	I (if protective earth is connected by customer)
Product conforming to standard	EN 61800-5-1; CE
Approval	CSA C22.2 No.77; UL 2111

R3G630-AB06-61

Emerson

EC centrifugal fan

backward curved, single inlet

Product drawing

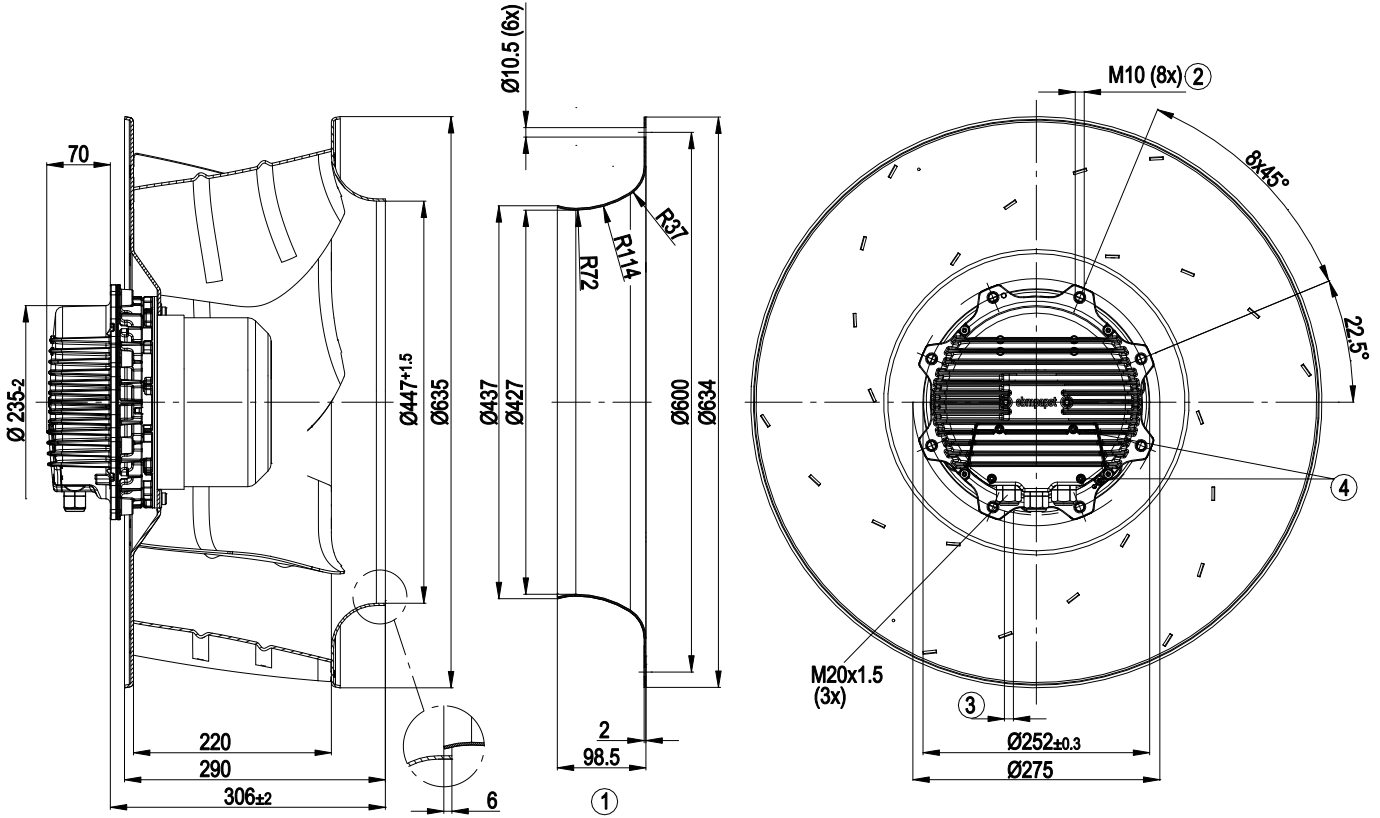

1	Accessory part: Inlet nozzle 63070-2-4013, not included in the standard scope of delivery.
2	Depth of screw max. 25 mm
3	Cable diameter: min. 4 mm, max. 10 mm, tightening torque: 4±0.6 Nm
4	Tightening torque 3.5±0.5 Nm



Connection screen

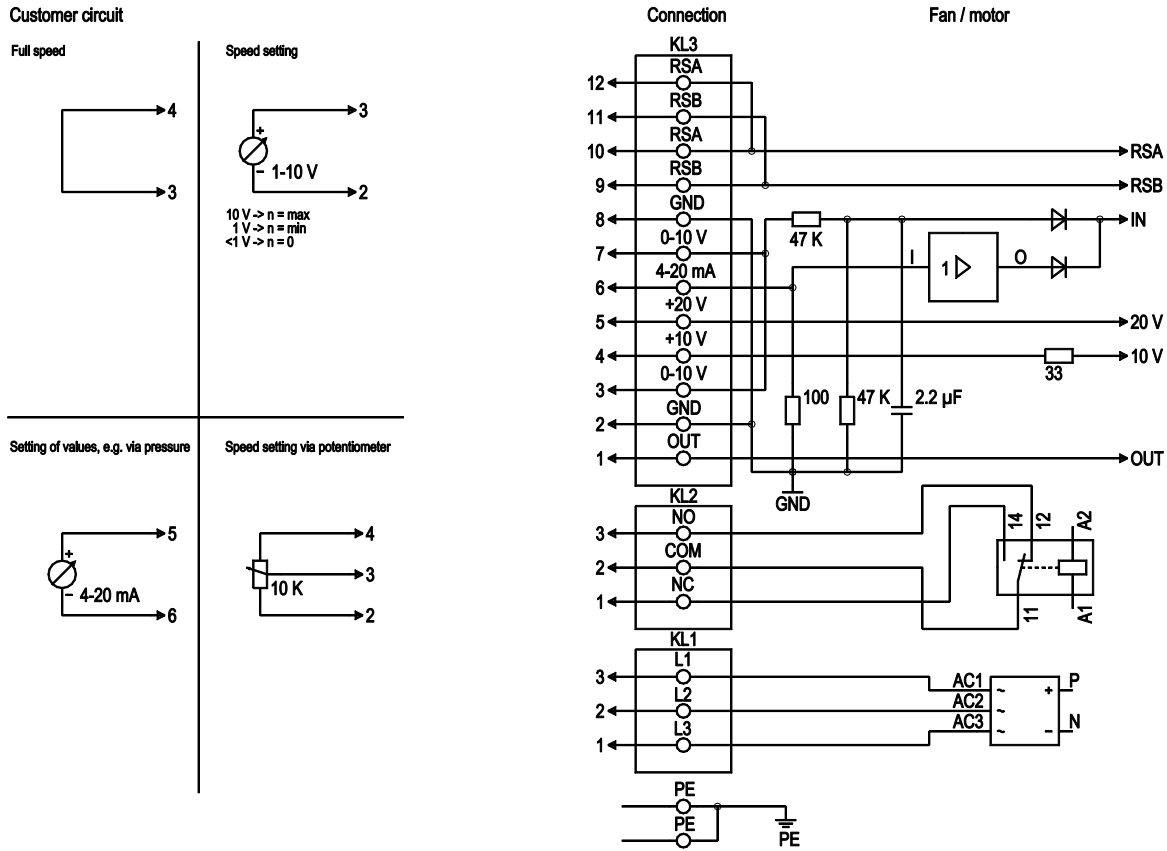

No.	Conn.	Designation	Function / assignment
PE		PE	Protective earth connection
KL1	1, 2, 3	L1, L2, L3	Supply voltage, 50/60 Hz
KL2	1	NC	Floating status message contact, normally closed connection
KL2	2	COM	Floating status message contact, changeover contact, common connection (2 A, max. 250 VAC, min. 10 mA, AC1)
KL2	3	NO	Floating status message contact, normally open connection
KL3	1	OUT	Analog output, 0-10 VDC, max. 3 mA, SELV, output of the current level control coefficient: 1 V equates to 10 % level control coefficient. 10 V equate to 100 % level control coefficient.
KL3	2, 8	GND	Reference mass for control interface, SELV
KL3	3, 7	0-10 V	Use control / actual value input 0-10 VDC, impedance 100 kΩ only as alternative to 4-20 mA input, SELV
KL3	4	+10 V	Voltage output 10 VDC (+/-3 %), max. 10 mA, supply voltage for ext. devices (e.g. potentiometers), SELV
KL3	5	+20 V	Voltage output 20 VDC (+25 %/-10 %), max. 50 mA, supply voltage for ext. devices (e.g. sensors), SELV
KL3	6	4-20 mA	Use control / actual value input 4-20 mA, impedance 100 Ω, only as alternative to 0-10 V input, SELV
KL3	9, 11	RSB	RS485 interface for ebmBus, RSB, SELV
KL3	10, 12	RSA	RS485 interface for ebmBus, RSA, SELV



Charts: Air flow 50 Hz

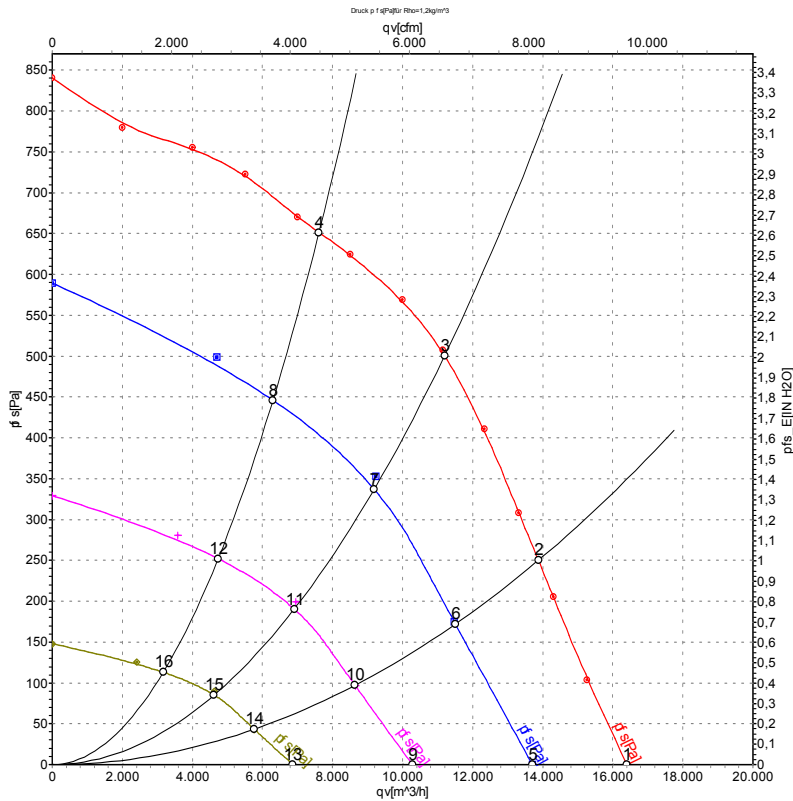

Measurement: LU-109182-1
 Measurement: LU-116038-1
 Measurement: LU-114211-1
 Measurement: LU-114210-1

Air performance measured as per ISO 5801 Installation category A. For detailed information on the measuring set-up, please contact ebmpapst. Suction-side noise levels: L_{wA} measured as per ISO 13347 / L_{pA} measured with 1m distance to fan axis. The values given are valid under the measuring conditions mentioned above and may vary according to the actual installation situation. With any deviation from the standard set-up, the specific values have to be checked and reviewed with the unit installed.

Measured values

	Conn.	U	f	n	P _{ed}	I	LpA _{in}	LwA _{in}	LwA _{out}	qv	p _{fs}	qv	p _{fs}
		V	Hz	min ⁻¹	W	A	dB(A)	dB(A)	dB(A)	m ³ /h	Pa	CFM	inH ₂ O
1	Y	400	50	1200	2020	3.07	78	85	91	16410	0	9660	0.00
2	Y	400	50	1200	2458	3.72	74	82	88	13880	250	8170	1.00
3	Y	400	50	1200	2800	4.20	72	79	86	11200	500	6590	2.01
4	Y	400	50	1200	2629	3.98	73	81	87	7615	650	4480	2.61
5	Y	400	50	1000	1103	1.70	72	79	85	13700	0	8065	0.00
6	Y	400	50	1000	1315	2.01	69	76	82	11510	171	6775	0.69
7	Y	400	50	1000	1520	2.32	67	74	81	9190	354	5410	1.42
8	Y	400	50	1000	1338	2.05	68	75	82	6300	447	3710	1.79
9	Y	400	50	750	474	0.82	64	71	77	10280	0	6050	0.00
10	Y	400	50	750	554	0.92	61	68	74	8645	96	5085	0.39
11	Y	400	50	750	654	1.05	59	67	73	6905	200	4065	0.80
12	Y	400	50	750	572	0.94	60	67	74	4735	253	2790	1.02
13	Y	400	50	500	161	0.35	53	60	66	6870	0	4040	0.00
14	Y	400	50	500	179	0.38	50	57	63	5765	43	3395	0.17
15	Y	400	50	500	208	0.43	49	57	63	4620	90	2720	0.36
16	Y	400	50	500	188	0.40	49	56	63	3170	113	1865	0.45

Conn. = Connection · U = Supply voltage · f = Frequency · n = Speed (rpm) · P_{ed} = Power input · I = Current draw · LpA_{in} = Sound pressure level inlet side · LwA_{in} = Sound power level inlet side
 LwA_{out} = Sound power level outlet side · qv = Air flow · p_{fs} = Pressure increase

