

R3G630-AA08-03

EC centrifugal fan

backward curved, single inlet



R3G630-AA08-03 ebmpapst Datasheet FansCo

sales@fansco.com

www.fansco.com

Nominal data

Type	R3G630-AA08-03	
Motor	M3G150-FF	
Phase		3~
Nominal voltage	VAC	400
Nominal voltage range	VAC	380 .. 480
Frequency	Hz	50/60
Type of data definition		ml
Speed (rpm)	min ⁻¹	1000
Power input	W	1700
Current draw	A	2.6
Min. ambient temperature	°C	-25
Max. ambient temperature	°C	60

ml = Max. load · me = Max. efficiency · fa = Running at free air · cs = Customer specs · cu = Customer unit
Subject to alterations

Data in accordance with ecodesign regulation EU 327/2011

		Actual	Request 2015
01 Overall efficiency η_{es}	%	57.2	53.9
02 Measurement category		A	
03 Efficiency category		Static	
04 Efficiency grade N		65.3	62
05 Variable speed drive		Yes	

Data definition with optimum efficiency.

The ErP data is determined using a motor-impeller combination in a standardised measurement configuration.

09 Power input P_{ed}	kW	1.68
09 Air flow q_v	m ³ /h	9005
09 Pressure increase p_{fs}	Pa	359
10 Speed (rpm) n	min ⁻¹	1005
11 Specific ratio*		1.00

* Specific ratio = $1 + p_{fs} / 100\,000\text{ Pa}$

LU-109100



Technical features

Mass	24 kg
Size	630 mm
Motor size	150
Surface of rotor	Coated in black
Material of electronics housing	Die-cast aluminium
Material of impeller	Sheet aluminium, laser-welded
Number of blades	6
Direction of rotation	Clockwise, seen on rotor
Protection rating	IP55
Insulation class	"F"
Humidity (F) / environmental protection class (H)	F4-1
Max. permissible ambient motor temp. (transp./ storage)	+80 °C
Min. permissible ambient motor temp. (transp./storage)	-40 °C
Mounting position	Shaft horizontal or rotor on bottom; rotor on top on request
Condensation drainage holes	Rotor-side
Operation mode	Continuous operation (S1)
Motor bearing	Ball bearing
Technical features	<ul style="list-style-type: none"> - Output 10 VDC, max. 10 mA - Output 20 VDC, max. 50 mA - Output for slave 0-10 V - Input for sensor 0-10 V or 4-20 mA - Alarm relay - Integrated PID controller - Motor current limit - PFC, passive - RS485 ebmBUS - Soft start - Control input 0-10 VDC / PWM - Control interface with SELV potential safely disconnected from the mains - Over-temperature protected electronics / motor - Line undervoltage / phase failure detection
EMC interference immunity	Acc. to EN 61000-6-2 (industrial environment)
EMC interference emission	Acc. to EN 61000-6-3 (household environment)
Touch current acc. IEC 60990 (measuring network Fig. 4, TN system)	<= 3.5 mA
Electrical connection	Terminal box
Motor protection	Reverse polarity and locked-rotor protection
Protection class	I (if protective earth is connected by customer)
Product conforming to standard	EN 61800-5-1; CE
Approval	VDE; CSA C22.2 no. 77; EAC

Product drawing

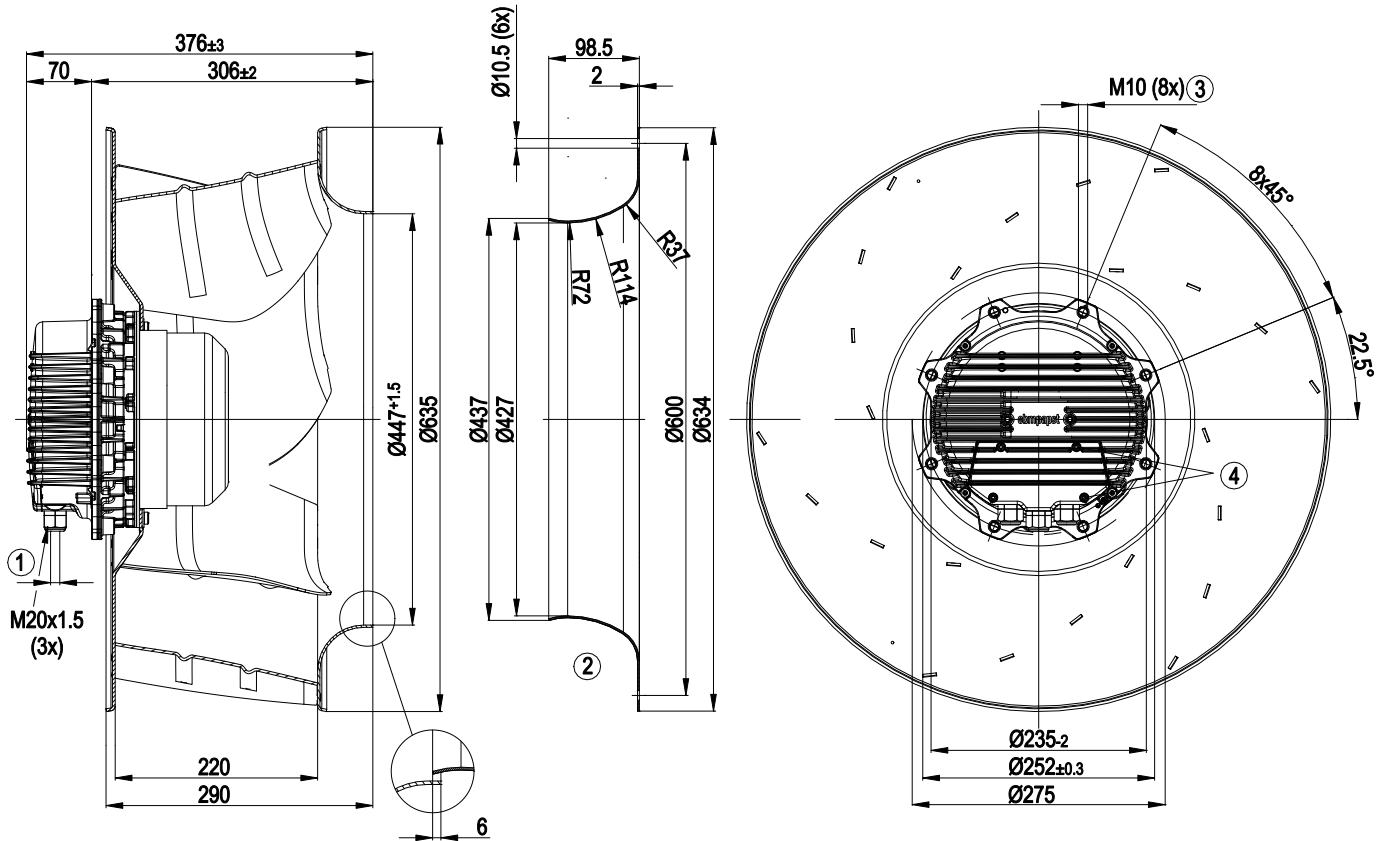

1	Cable diameter: min. 4 mm, max. 10 mm, tightening torque: 4±0.4 Nm
2	Accessory part: inlet nozzle 63070-2-4013 not included in the standard scope of delivery; other inlet nozzles on request
3	Depth of screw max. 25 mm
4	Tightening torque 3.5±0.5 Nm

EC centrifugal fan

backward curved, single inlet

Connection screen

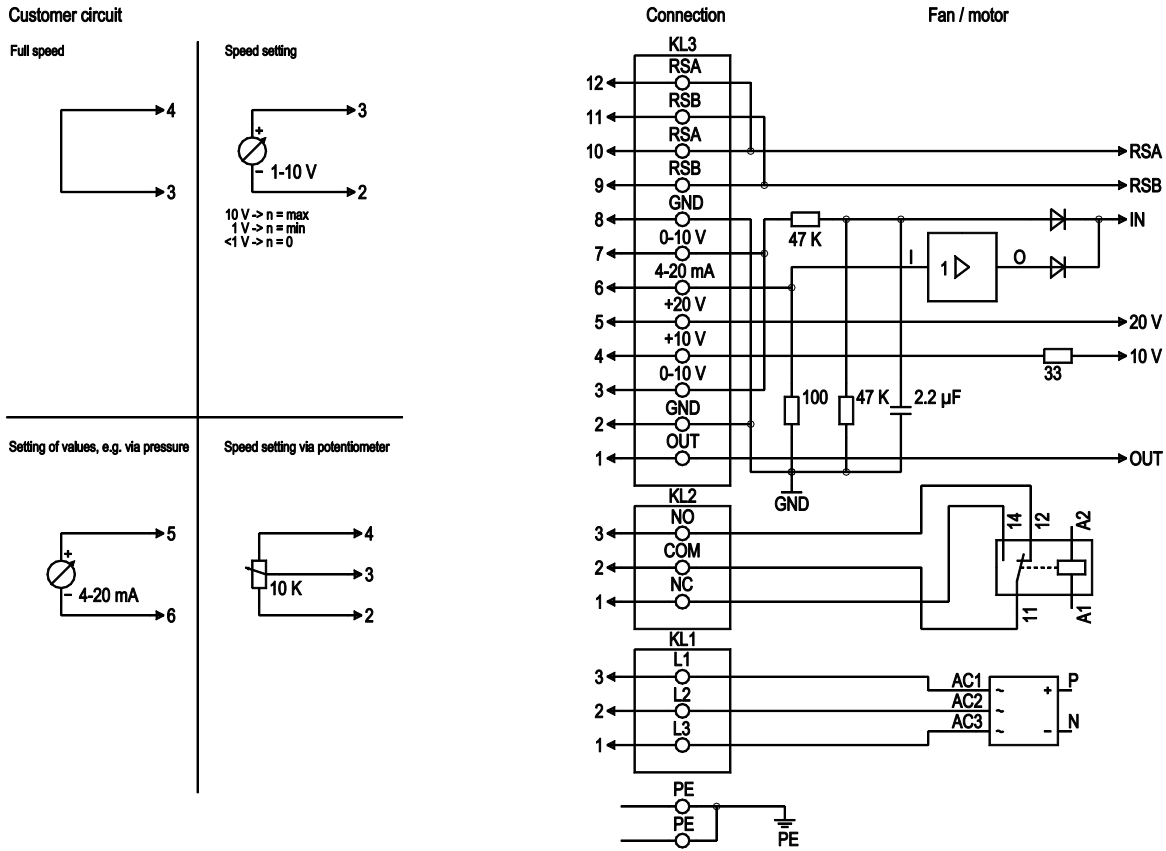

No.	Conn.	Designation	Function / assignment
PE		PE	Protective earth connection
KL1	1, 2, 3	L1, L2, L3	Supply voltage, 50/60 Hz
KL2	1	NC	Floating status message contact, normally closed connection
KL2	2	COM	Floating status message contact, changeover contact, common connection (2 A, max. 250 VAC, min. 10 mA, AC1)
KL2	3	NO	Floating status message contact, normally open connection
KL3	1	OUT	Analog output, 0-10 VDC, max. 3 mA, SELV, output of the current level control coefficient: 1 V equates to 10 % level control coefficient. 10 V equate to 100 % level control coefficient.
KL3	2, 8	GND	Reference mass for control interface, SELV
KL3	3, 7	0-10 V	Use control / actual value input 0-10 VDC, impedance 100 kΩ only as alternative to 4-20 mA input, SELV
KL3	4	+10 V	Voltage output 10 VDC (+/-3 %), max. 10 mA, supply voltage for ext. devices (e.g. potentiometers), SELV
KL3	5	+20 V	Voltage output 20 VDC (+25 %/-10 %), max. 50 mA, supply voltage for ext. devices (e.g. sensors), SELV
KL3	6	4-20 mA	Use control / actual value input 4-20 mA, impedance 100 Ω, only as alternative to 0-10 V input, SELV
KL3	9, 11	RSB	RS485 interface for ebmBus, RSB, SELV
KL3	10, 12	RSA	RS485 interface for ebmBus, RSA, SELV



Charts: Air flow 50 Hz

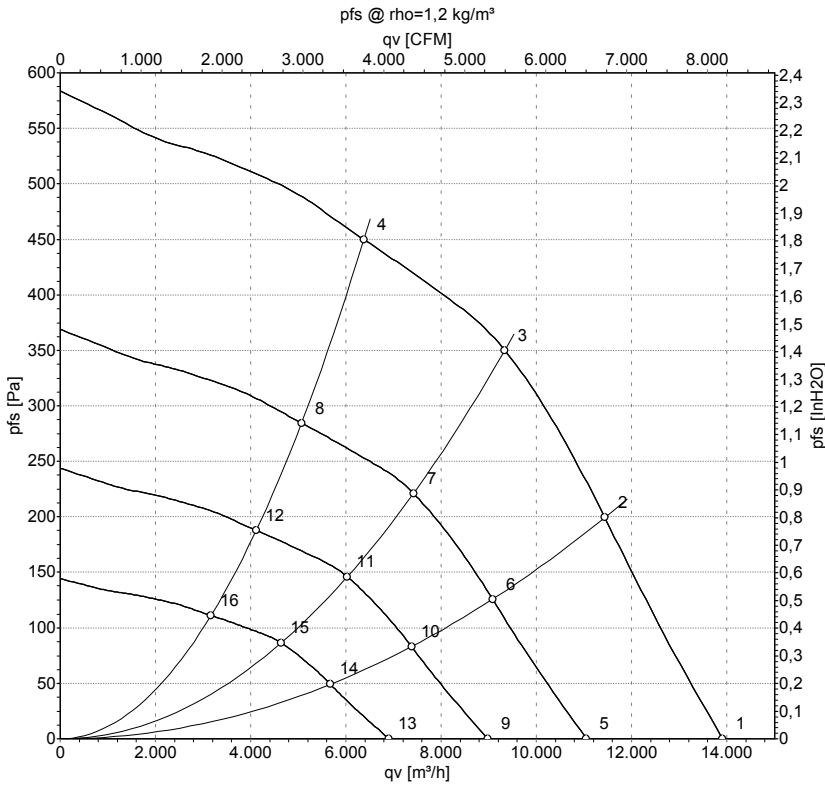

Measurement: LU-109100-1

Air performance measured as per ISO 5801 Installation category A. For detailed information on the measuring set-up, please contact ebm-papst. Suction-side noise levels: LwA measured as per ISO 13347 / LpA measured with 1m distance to fan axis. The values given are valid under the measuring conditions mentioned above and may vary according to the actual installation situation. With any deviation from the standard set-up, the specific values have to be checked and reviewed with the unit installed.

Measured values

	Conn.	U	f	n	P _{ed}	I	LpA _{in}	LwA _{in}	LwA _{out}	q _v	p _{fs}	q _v	p _{fs}
		V	Hz	min ⁻¹	W	A	dB(A)	dB(A)	dB(A)	m ³ /h	Pa	cfm	in. wg
1	Y	400	50	1000	1141	1.74	73	80	85	13905	0	8185	0.00
2	Y	400	50	1000	1475	2.22	69	76	82	11435	199	6730	0.80
3	Y	400	50	1000	1700	2.60	68	75	81	9330	350	5495	1.41
4	Y	400	50	1000	1533	2.32	68	76	82	6370	450	3750	1.81
5	Y	400	50	800	572	0.87	67	74	79	11045	0	6500	0.00
6	Y	400	50	800	739	1.11	63	71	76	9080	126	5345	0.51
7	Y	400	50	800	855	1.28	62	69	75	7415	221	4365	0.89
8	Y	400	50	800	771	1.17	63	70	76	5065	284	2980	1.14
9	Y	400	50	650	307	0.47	62	69	74	8975	0	5285	0.00
10	Y	400	50	650	396	0.60	58	65	71	7375	83	4340	0.33
11	Y	400	50	650	467	0.69	57	64	70	6025	146	3545	0.59
12	Y	400	50	650	414	0.63	57	65	71	4115	188	2425	0.75
13	Y	400	50	500	140	0.21	56	63	68	6905	0	4065	0.00
14	Y	400	50	500	180	0.27	52	59	64	5675	49	3340	0.20
15	Y	400	50	500	212	0.31	50	57	63	4635	86	2730	0.35
16	Y	400	50	500	188	0.28	51	58	64	3165	111	1865	0.45

Conn. = Connection · U = Supply voltage · f = Frequency · n = Speed (rpm) · P_{ed} = Power input · I = Current draw · LpA_{in} = Sound pressure level inlet side · LwA_{in} = Sound power level inlet side
 LwA_{out} = Sound power level outlet side · q_v = Air flow · p_{fs} = Pressure increase

