

R3G595-AB29-16 ebmpapst Datasheet

sales@fansco.com

www.fansco.com

Limited partnership · Headquarters Mulfingen

Amtsgericht (court of registration) Stuttgart · HRA 590344

General partner Elektrobau Mulfingen GmbH · Headquarters Mulfingen

Amtsgericht (court of registration) Stuttgart · HRB 590142

Nominal data

Type	R3G595-AB29-16	
Motor	M3G150-IF	
Phase		3~
Nominal voltage	VAC	200
Nominal voltage range	VAC	200 .. 240
Frequency	Hz	50/60
Method of obtaining data		ml
Status		prelim.
Speed (rpm)	min ⁻¹	1400
Power consumption	W	2950
Current draw	A	9.0
Min. ambient temperature	°C	-40
Max. ambient temperature	°C	55

ml = Max. load · me = Max. efficiency · fa = Free air · cs = Customer specification · ce = Customer equipment
Subject to change

Data according to Commission Regulation (EU) 327/2011

		Actual	Req. 2015			
01 Overall efficiency η_{es}	%	66.3	56.1	09 Power consumption P_{ed}	kW	2.74
02 Measurement category		A		09 Air flow q_v	m ³ /h	8585
03 Efficiency category		Static		09 Pressure increase p_{fs}	Pa	725
04 Efficiency grade N		72.2	62	10 Speed (rpm) n	min ⁻¹	1400
05 Variable speed drive		Yes		11 Specific ratio [*]		1.01

Data obtained at optimum efficiency level.

The ErP data is determined using a motor-impeller combination in a standardized measurement setup.

^{*} Specific ratio = $1 + p_{fs} / 100\,000\text{ Pa}$

LU-194844



Technical description

Weight	0.001 kg
Size	595 mm
Motor size	150
Rotor surface	Painted black
Electronics housing material	Die-cast aluminum
Impeller material	PP plastic
Number of blades	6
Direction of rotation	Clockwise, viewed toward rotor
Degree of protection	IP55
Insulation class	"F"
Moisture (F) / Environmental (H) protection class	H1
Ambient temperature note	Occasional start-up at temperatures between -40°C and -25°C is permitted. For continuous operation at ambient temperatures below -25°C (such as refrigeration applications), use must be made of a fan design with special low-temperature bearings.
Max. permitted ambient temp. for motor (transport/storage)	+80 °C
Min. permitted ambient temp. for motor (transport/storage)	-40 °C
Installation position	Shaft horizontal or rotor on bottom; rotor on top on request
Condensation drainage holes	On rotor side
Mode	S1
Motor bearing	Ball bearing
Technical features	<ul style="list-style-type: none"> - Operation and alarm display with LED - External 15-50 VDC input (parameterization) - Alarm relay - Integrated PI controller - Configurable inputs/outputs (I/O) - MODBUS V6.0 - Motor current limitation - RFID - ISO 15693 compatible - RS-485 MODBUS-RTU - Soft start - Voltage output 3.3-24 VDC, Pmax = 800 mW - Control interface with SELV potential safely disconnected from the mains - Thermal overload protection for electronics/motor - Line undervoltage / phase failure detection
Touch current according to IEC 60990 (measuring circuit Fig. 4, TN system)	<= 3.5 mA
Electrical hookup	Connector with cable
Motor protection	Reverse polarity and locked-rotor protection
Protection class	I (with customer connection of protective earth)
Conformity with standards	EN 61800-5-1; CE
Approval	EAC

Product drawing

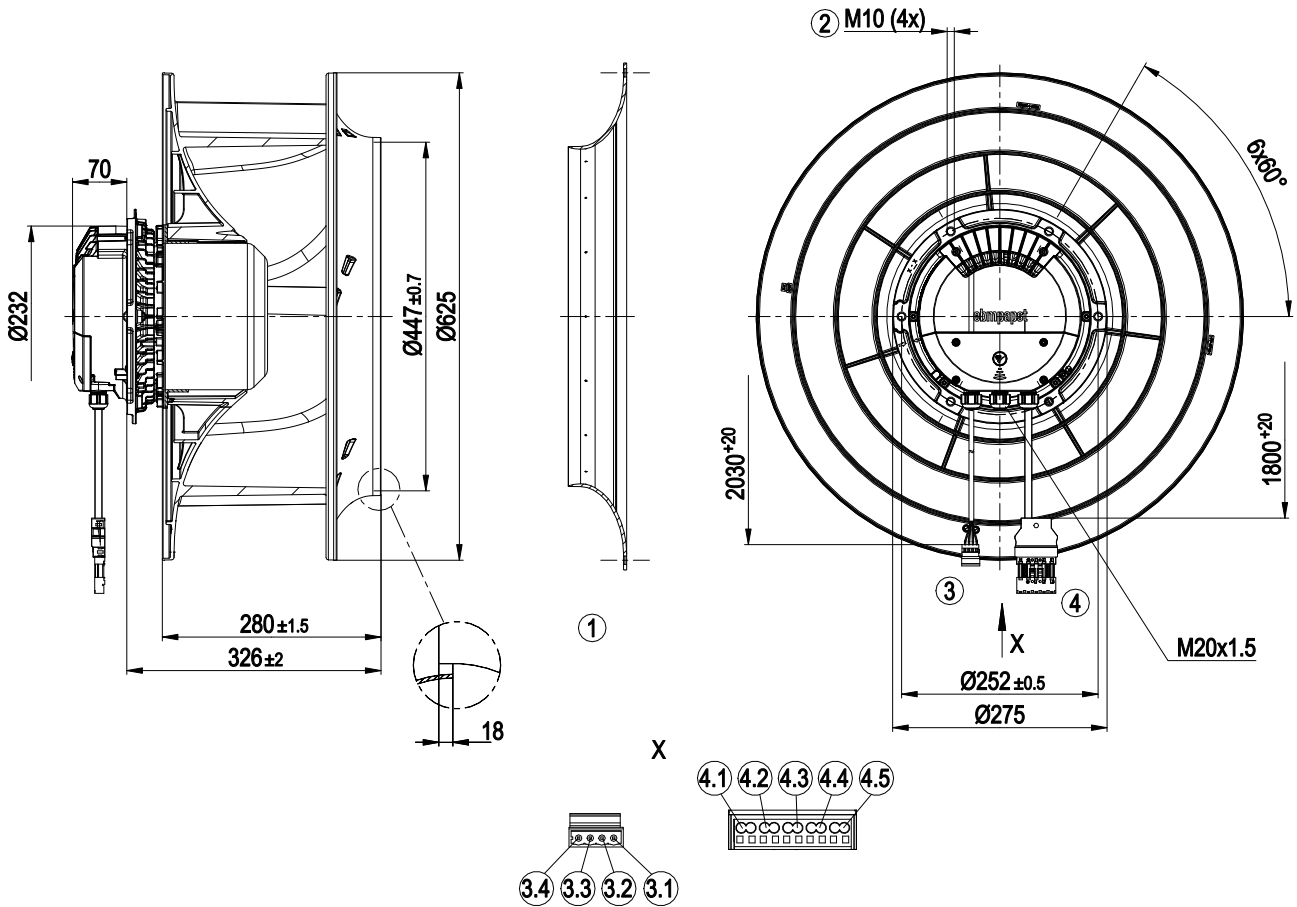

1	Accessory part: inlet ring 59520-2-2943 not included in scope of delivery
2	Max. clearance for screw 20 mm
3	Cable Ölflex Classic 110 4x 0.75 mm ² 4-pole header Wago 231-604
3.1	GND
3.2	IO2
3.3	COM / IO1 with bridge
3.4	NC
4	Cable Ölflex Classic 110 4G 2.5 mm ² Plug with strain relief 5-pole Wago 0770-001/K011-0174/0000-0300
4.1	Not used / no function
4.2	PE
4.3	L1
4.4	L2
4.5	L3

Accessory part

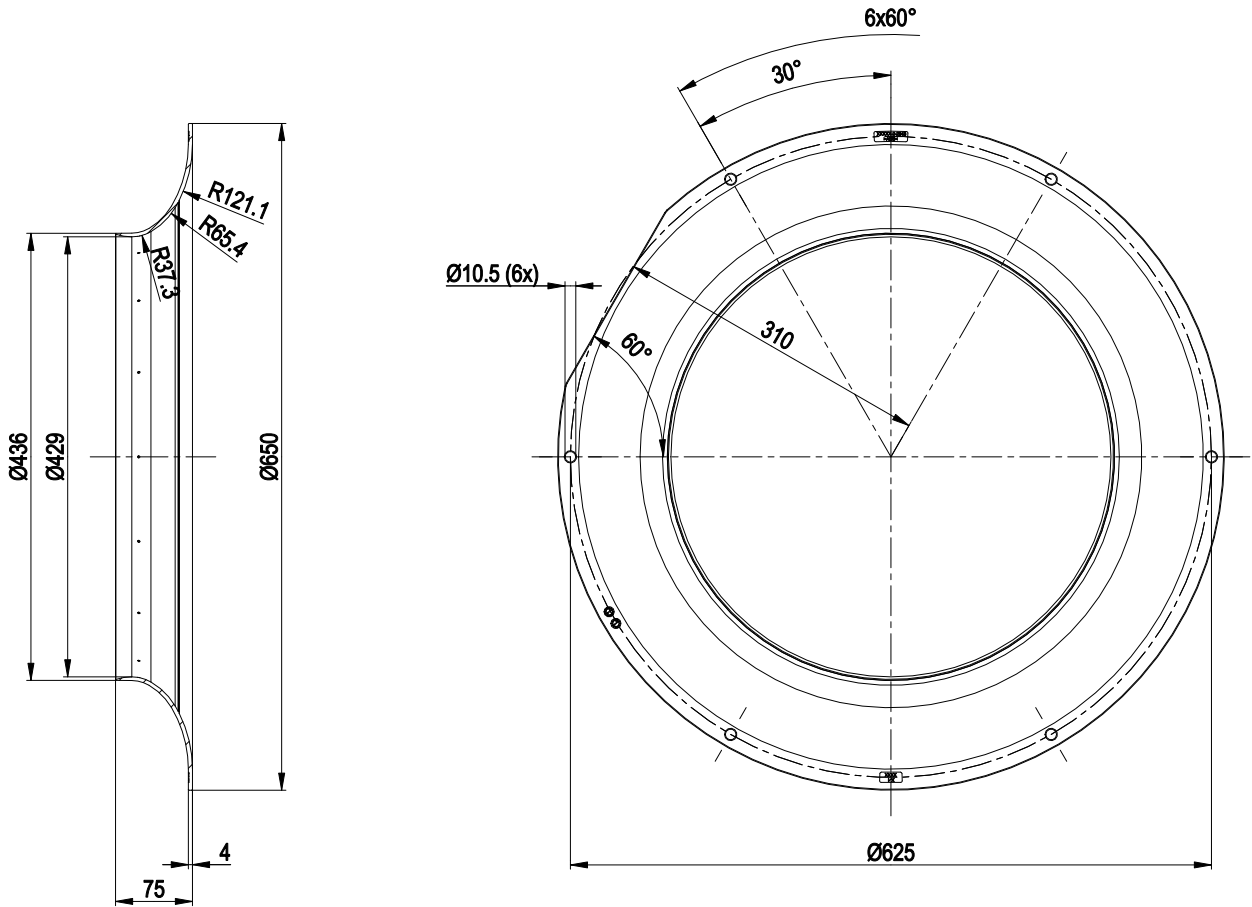

1 Accessory part: inlet ring 59520-2-2943 not included in scope of delivery



EC centrifugal fan

backward-curved, single-intake

Connection diagram

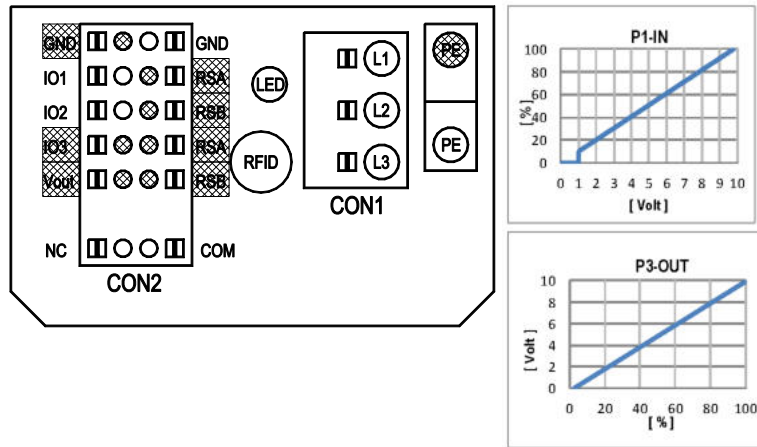

shaded gray => not brought out via leads

No.	Conn.	Designation	Function/assignment
	CON1	L1, L2, L3	Power supply, phase, see nameplate for voltage range
	PE	PE	Protective earth
	CON2	RSA	RS485 interface for MODBUS, RSA; SELV
	CON2	RSB	RS485 interface for MODBUS, RSB; SELV
	CON2	GND	Reference ground for control interface, SELV
	CON2	IO1	Function parameterizable (see "Optional interface functions" table) Factory setting: Digital input - high active, function: Enable input, SELV - inactive: Pin open or applied voltage < 1.5 VDC / < 0.7 VAC - active: applied voltage 3.5-50 VDC / 7-30 VAC Reset function: Triggering of error reset on change of state from "enabled" to "disabled".
	CON2	IO2	Function parameterizable (see "Optional interface functions" table) Factory setting: Analog input 0-10 V / PWM, Ri=100 kΩ, function: Set value Characteristic curve parameterizable (see input characteristic curve P1-IN), SELV
	CON2	IO3	Function parameterizable (see "Optional interface functions" table) Factory setting: Analog output 0-10 V, max. 5 mA, function: Fan modulation level Characteristic curve parameterizable (see output characteristic curve P3-OUT), SELV
	CON2	Vout	Voltage output 3.3-24 VDC ±5%, Pmax=800 mW, voltage parameterizable Factory setting: 10 VDC short-circuit-proof, supply for external devices, SELV alternatively: 15-50 VDC input for parameterization via MODBUS without line voltage
	CON2	COM	Status relay, floating status contact, common connection, contact rating 250 VAC / 2 A (AC1) / min. 10 mA, reinforced insulation on supply side and on control interface side
	CON2	NC	Status relay, floating status contact, break for failure or n < 200 rpm
		LED	green: status = good, ready for operation orange: status = warning red: status = failure
		P1-IN	Input characteristic curve
		P3-OUT	Output characteristic curve



Terminal/plug assignment

CON2	configurable IO mode	electrical specification	configurable IO functions: normal / inverse	MODBUS Register for IO mode configuration	INPUT	OUTPUT
101	○ Din1 (active high), digital input	not active: pin open or applied voltage < 1.5VDC active: applied voltage 3.5-50VDC, SELV		D158 [0]	switch: set value source	signal: tach out
	○ Ain1 0-10V/PWM: analog input	Ri=100k, characteristic curve parameterizable, f _{PWM} =1k..10kHz, SELV		D158 [2]	switch: fan enable / disable	signal: diagnostics out (selected directly via IO mode)
	○ Tacho out (open collector output)	U _{max} =50VDC, I _{max} =20mA, SELV		D158 [5]	switch: direction of rotation: cw / ccw	signal: fan modulation level %
	○ Diagnostics out (open collector output)	U _{max} =50VDC, I _{max} =20mA, SELV		D158 [6]	switch: control function: heating (pos.), cooling (neg.)	signal: actual speed
102	○ Din2 (active high), digital input	not active: pin open or applied voltage < 1.5VDC active: applied voltage 3.5-50VDC, SELV		D159 [0]	switch: parameter set: #1 / #2	signal: tach out (selected directly via IO mode)
	○ Ain2 0-10V/PWM: analog input ○ Ain2 4-20mA: analog input	Ri=100k, characteristic curve parameterizable, f _{PWM} =1k..10kHz, SELV Ri=125R, characteristic curve parameterizable, SELV		D159 [2] D159 [3]	source: sensor value	signal: remote control output 0-10V
103	○ Din3 (active high), digital input	not active: pin open or applied voltage < 1.5VDC active: applied voltage 3.5-50VDC, SELV		D15A [0]	source: set value	signal: fan modulation level %
	○ Din3 (active low), digital input	not active: pin open or applied voltage < 1.5VDC active: applied voltage 3.5-50VDC, SELV		D15A [1]	switch: set value source	signal: system modulation level %
	○ PWMIn3: digital input	not active: pin open or applied voltage < 1.5VDC active: applied voltage < 1.5VDC, SELV 40Hz - 10kHz, characteristics parameterizable		D15A [7]	switch: direction of rotation: cw / ccw	signal: actual speed
	○ Aout3 0-10V: analog output ○ Tacho out (pulses), analog output ○ Diagnostics out (pulses)	not active: pin open or applied voltage < 1.5VDC, SELV active: applied voltage < 1.5VDC, SELV function parameterizable, max. 5mA, max output frequency 300Hz, SELV 0-10V max. 5mA, max output frequency 300Hz, SELV 0-10V max. 5mA, max output frequency 300Hz, SELV		D15A [4] D15A [5] D15A [6]	switch: control function: heating (pos.), cooling (neg.)	signal: tach out (selected directly via IO mode)
RSA RSB	RS485 bus connection,	MODBUS RTU, specification V6.0, SELV				
Vout	voltage output alternatively: input auxiliary power supply for parameterization via RS485/MODBUS RTU without line voltage	voltage parameterizable 3.3...24VDC +/- 5.5%, P _{max} =800mW, short-circuit-proof, supply for external devices, SELV 15...50VDC				

○ configurable option

For further information and additional functions see EC Control Software, Fan-Set-App, or MODBUS Parameter Specification V6.0



Curves: Air performance 50 Hz

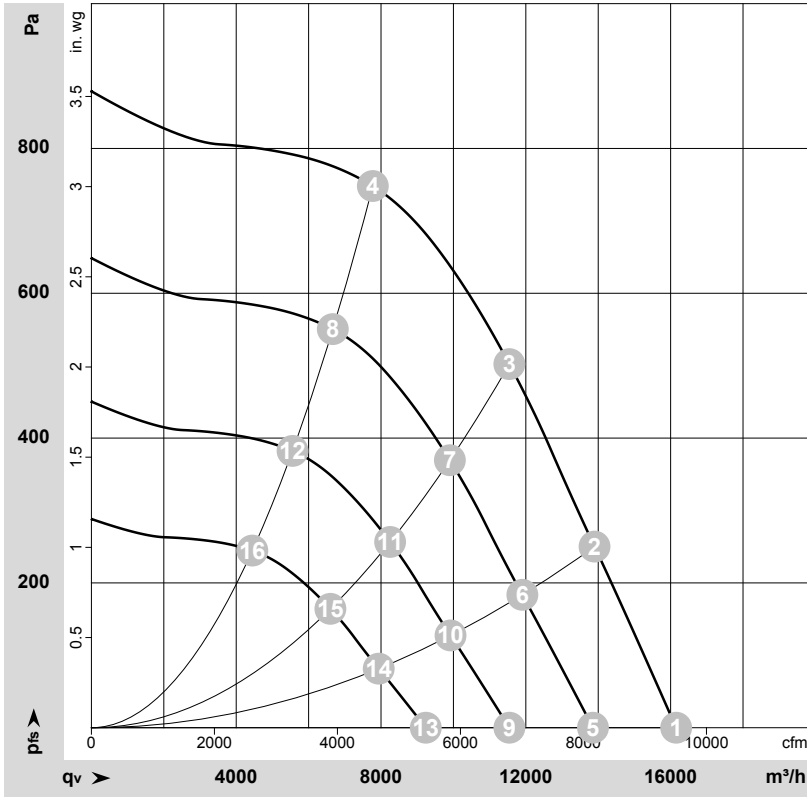

$\rho = 1.15 \text{ kg/m}^3 \pm 2 \%$

Measurement: LU-194844-1

Air performance measured according to ISO 5801 installation category A. For detailed information on the measurement setup, contact ebmpapst. Intake sound level: Sound power level according to ISO 13347 / sound pressure level measured at 1 m distance from fan axis. The values given are valid under the specified measuring conditions and may vary due to conditions of installation. For deviations from the standard configuration, the parameters have to be checked on the installed unit.

Measured values

	Wired	U	f	n	P _{ed}	I	LpA _{in}	LwA _{in}	LwA _{out}	q _v	p _{fs}	q _v	p _{fs}
		V	Hz	min ⁻¹	W	A	dB(A)	dB(A)	dB(A)	m ³ /h	Pa	cfm	in. wg
1	3~	200	50	1400	2207	6.74	82	92	94	16155	0	9505	0.00
2	3~	200	50	1400	2625	7.97	80	91	92	13900	250	8180	1.00
3	3~	200	50	1400	2950	9.00	75	85	88	11545	500	6795	2.01
4	3~	200	50	1400	2663	8.09	70	80	85	7775	750	4575	3.01
5	3~	200	50	1200	1393	4.25	78	88	90	13855	0	8155	0.00
6	3~	200	50	1200	1650	5.01	76	87	88	11905	184	7005	0.74
7	3~	200	50	1200	1834	5.58	71	81	84	9900	370	5830	1.49
8	3~	200	50	1200	1681	5.11	66	76	81	6670	551	3925	2.21
9	3~	200	50	1000	806	2.46	73	84	86	11545	0	6795	0.00
10	3~	200	50	1000	955	2.90	71	82	83	9920	127	5840	0.51
11	3~	200	50	1000	1061	3.23	67	76	80	8250	257	4855	1.03
12	3~	200	50	1000	973	2.96	61	72	77	5555	382	3270	1.53
13	3~	200	50	800	413	1.26	68	78	80	9235	0	5435	0.00
14	3~	200	50	800	489	1.48	66	76	78	7935	82	4670	0.33
15	3~	200	50	800	543	1.65	61	71	74	6600	164	3885	0.66
16	3~	200	50	800	498	1.51	56	66	71	4445	245	2615	0.98

Wired = Wiring · U = Voltage · f = Frequency · n = Speed (rpm) · P_{ed} = Power consumption · I = Current draw · LpA_{in} = Sound pressure level intake side · LwA_{in} = Sound power level intake side · LwA_{out} = Sound power level outlet side · q_v = Air flow · p_{fs} = Pressure increase

