

R3G560-RB32-10 ebmpapst Datasheet

sales@fansco.com

www.fansco.com

Nominal data

Type	R3G560-RB32-10	
Motor	M3G150-IF	
Phase		3~
Nominal voltage	VAC	400
Nominal voltage range	VAC	380 .. 480
Frequency	Hz	50/60
Type of data definition		ml
Speed (rpm)	min ⁻¹	1650
Power input	W	2900
Current draw	A	4.43
Min. ambient temperature	°C	-25
Max. ambient temperature	°C	50

ml = Max. load · me = Max. efficiency · fa = Running at free air · cs = Customer specs · cu = Customer unit
Subject to alterations

Data according to ErP directive

		Actual	Request 2015			
01 Overall efficiency η_{es}	%	66.9	56.4	09 Power input P_{ed}	kW	2.93
02 Measurement category		A		09 Air flow q_v	m ³ /h	9440
03 Efficiency category		Static		09 Pressure increase p_{fs}	Pa	710
04 Efficiency grade N		72.5	62	10 Speed (rpm) n	min ⁻¹	1655
05 Variable speed drive		Yes		11 Specific ratio [*]		1.01

Data definition with optimum efficiency.

The ErP data is determined using a motor-impeller combination in a standardised measurement configuration.

^{*} Specific ratio = $1 + p_{fs} / 100\,000\text{ Pa}$

LU-145862



R3G560-RB32-10

EMERSON

EC centrifugal fan - RadiCal

backward curved, single inlet

Technical features

Mass	27.8 kg
Size	560 mm
Surface of rotor	Coated in black
Material of electronics housing	Die-cast aluminium
Material of impeller	PP plastic
Number of blades	6
Direction of rotation	Clockwise, seen on rotor
Type of protection	IP 55
Insulation class	"F"
Humidity (F)/environmental protection class (H)	F4-1
Max. permissible ambient motor temp. (transp./ storage)	+80 °C
Min. permissible ambient motor temp. (transp./storage)	-40 °C
Mounting position	Shaft horizontal or rotor on bottom
Condensate discharge holes	Rotor-side
Operation mode	S1
Motor bearing	Ball bearing
Technical features	<ul style="list-style-type: none"> - Output 10 VDC, max. 10 mA - Output 20 VDC, max. 50 mA - Output for slave 0-10 V - Operation and alarm display - Input for sensor 0-10 V or 4-20 mA - External 24 V input (programming) - External release input - Alarm relay - Integrated PID controller - Motor current limit - PFC, passive - RS485 MODBUS RTU - Soft start - Control input 0-10 VDC / PWM - Control interface with SELV potential safely disconnected from the mains - Over-temperature protected electronics / motor - Line undervoltage / phase failure detection
EMC interference immunity	Acc. to EN 61000-6-2 (industrial environment)
EMC interference emission	Acc. to EN 61000-6-3 (household environment), except EN 61000-3-2 for professionally used devices with a total rated power greater than 1 kW
Touch current acc. IEC 60990 (measuring network Fig. 4, TN system)	<= 3.5 mA
Leakage current (meas. network acc. IEC 60990, fig.4, TN sys.); normal operation	<= 3.5 mA
Leakage current (measured with TrueRMS amperemeter); normal operation	< 6 mA
Electrical leads	Via terminal box
Motor protection	Reverse polarity and locked-rotor protection



R3G560-RB32-10
EMERSON

EC centrifugal fan - RadiCal

backward curved, single inlet

Protection class	I (if protective earth is connected by customer)
Product conforming to standard	EN 61800-5-1; CE
Approval	UL 1004-7 + 60730; C22.2 Nr.77 + CAN/CSA-E60730-1



Product drawing

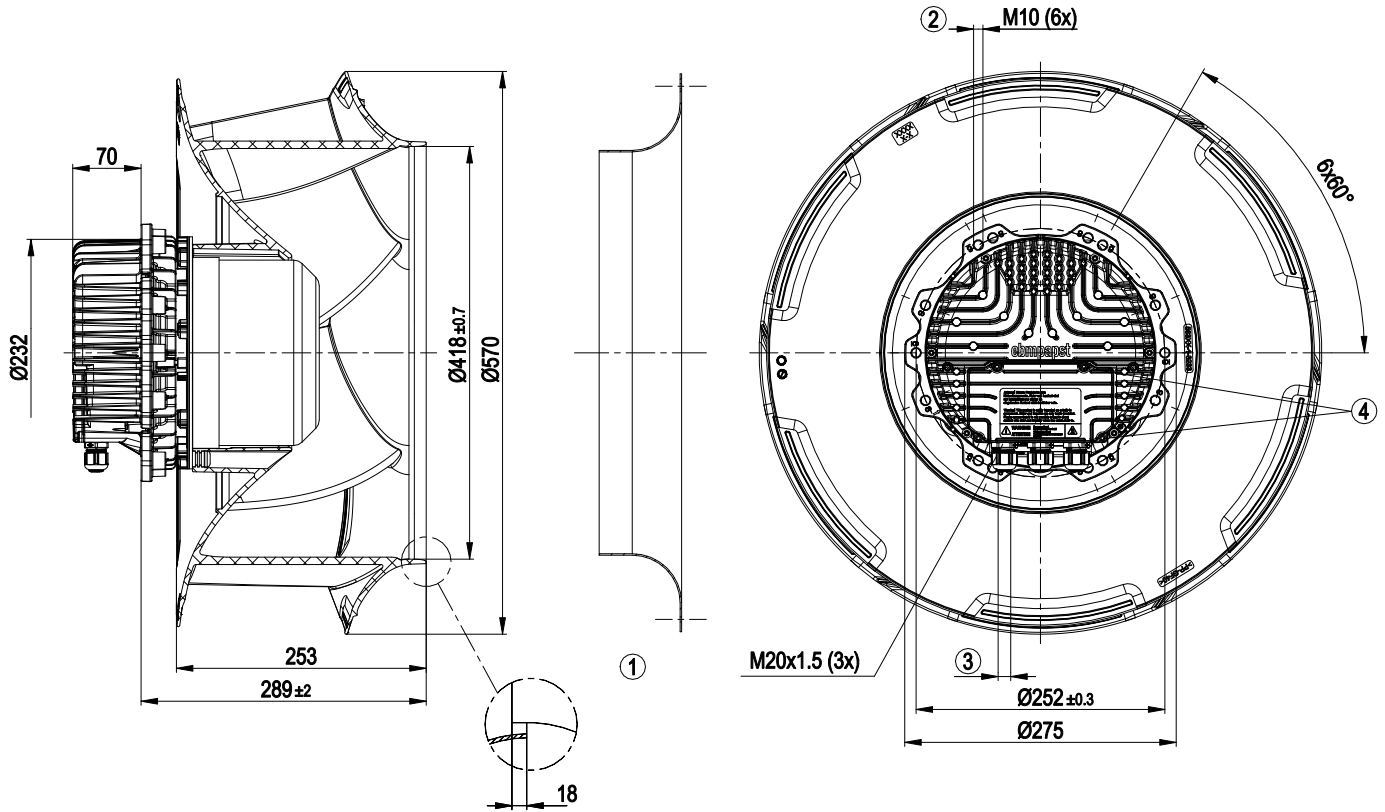

1	Accessory part: Inlet nozzle 54482-2-4013 not included in scope of delivery
2	Thread reach max. 25 mm
3	Cable diameter min. 4 mm, max. 10 mm, tightening torque 4 ± 0.6 Nm
4	Tightening torque 3.5 ± 0.5 Nm

Accessory part

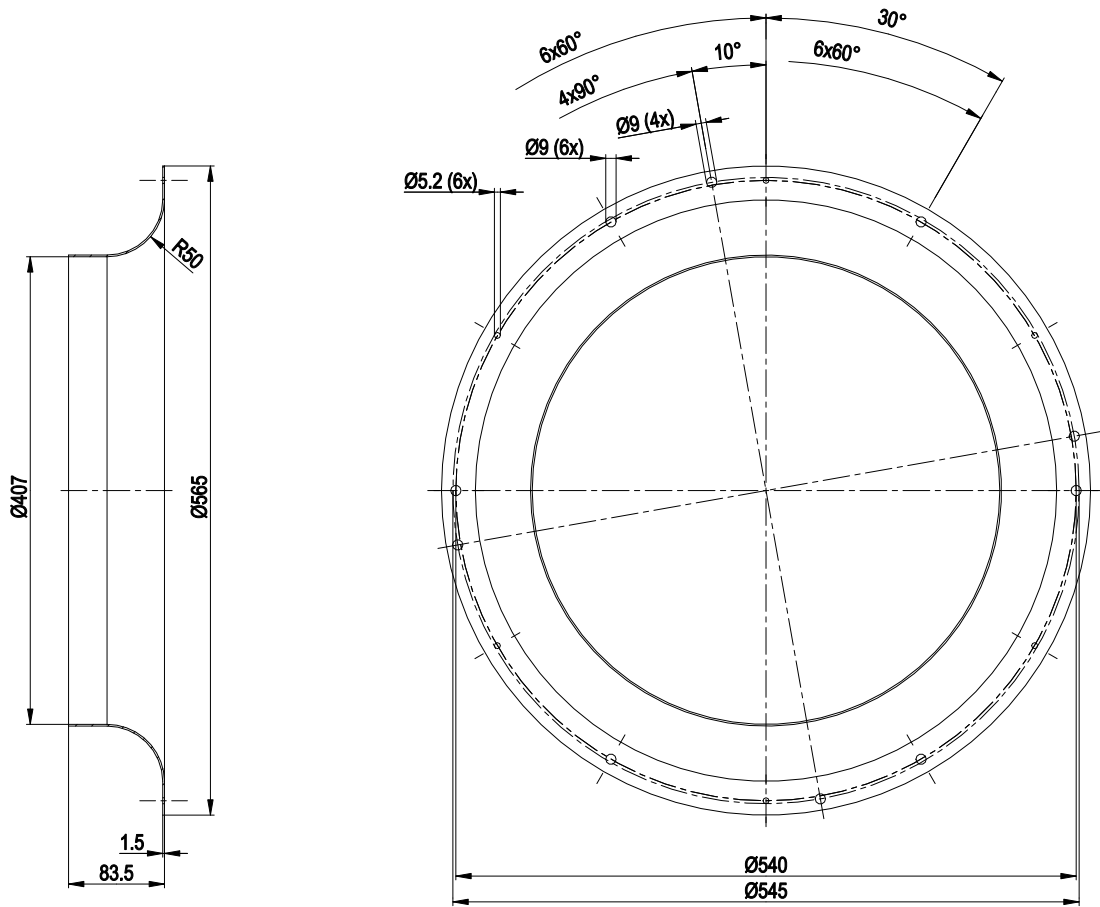

Accessory part: Inlet nozzle 54482-2-4013 not included in scope of delivery

Connection screen

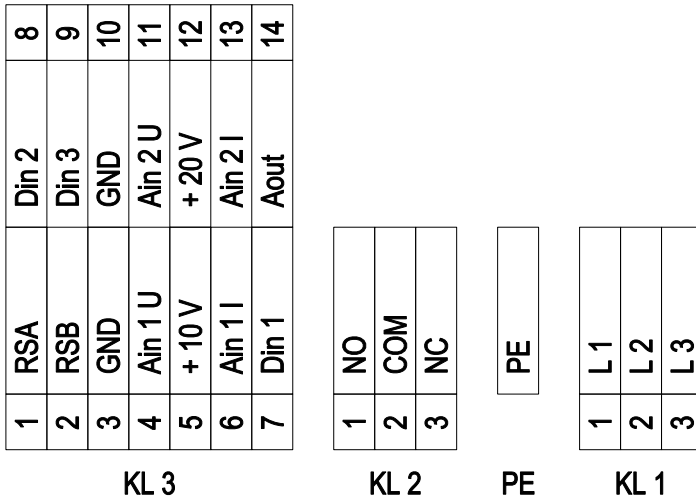

No.	Conn.	Designation	Function / assignment
KL 1	1	L1	Mains supply connection, supply voltage 3~380-480 VAC; 50/60 Hz
KL 1	2	L2	Mains supply connection, supply voltage 3~380-480 VAC; 50/60 Hz
KL 1	3	L3	Mains supply connection, supply voltage 3~380-480 VAC; 50/60 Hz
PE		PE	Earth connection, PE connection
KL 2	1	NO	Status relay, floating status contact; normally open; close with error
KL2	2	COM	Status relay; floating status contact; changeover contact; common connection; contact rating 250 VAC / max. 2 A (AC1) / min. 10 mA
KL2	3	NC	Status relay, floating status contact; break with error
KL 3	1	RSA	Bus connection RS-485, RSA, MODBUS RTU; SELV
KL 3	2	RSB	Bus connection RS-485, RSB, MODBUS RTU; SELV
KL 3	3 / 10	GND	Signal ground for control interface; SELV
KL 3	4	Ain1 U	Analogue input 1, set value: 0-10 V, Ri = 100 kΩ, parametrisable curve, only usable as alternative to input Ain1; SELV
KL 3	5	+ 10 V	Fixed voltage output 10 VDC, +10 V ±3%, max. 10 mA, short-circuit-proof, power supply for external devices (e.g. potentiometer), SELV
KL 3	6	Ain1 I	Analogue input 1, set value: 4-20 mA; Ri = 100 Ω, parametrisable curve, only usable as alternative to input Ain1 U; SELV
KL 3	7	Din1	Digital input 1: enabling of electronics, enabling: open pin or applied voltage 5-50 VDC disabling: bridge to GND or applied voltage <1 VDC reset function: triggers software reset after a level change to <1 VDC; SELV
KL 3	8	Din2	Digital input 2: parameter set switch 1/2, according to EEPROM setting, the valid/used parameter set can be selected via bus or via digital input DIN2. Parameter set 1: open pin or applied voltage 5-50 VDC Parameter set 2: bridge to GND or applied voltage <1 VDC; SELV
KL 3	9	Din3	Digital input 3: controller function of integrated controller, according to EEPROM setting, the controller function of the integrated controller is normally/inversely selectable per bus or per digital input normal: open pin or applied voltage 5-50 VDC inverse: bridge to GND or applied voltage <1 VDC; SELV
KL 3	11	Ain2 U	Analogue input 2, actual value: 0-10 V, Ri = 100 kΩ, parametrisable curve, only usable as alternative to input Ain2; SELV
KL 3	12	+ 20 V	Fixed voltage output 20 VDC, +20 V ±5/-10%, max. 50 mA, short-circuit-proof, power supply for external devices (e.g. sensors); SELV



R3G560-RB32-10

EMERSON

EC centrifugal fan - RadiCal

backward curved, single inlet

No.	Conn.	Designation	Function / assignment
KL 3	13	Ain2 I	Analogue input 2, actual value: 4-20 mA, Ri = 100 Ω , parametrisable curve, only usable as alternative to input Ain2 U; SELV
KL 3	14	Aout	Analogue output 0-10 VDC, max. 5 mA, output of the current motor level control coefficient / motor speed parametrisable curve; SELV



Charts: Air flow 50 Hz

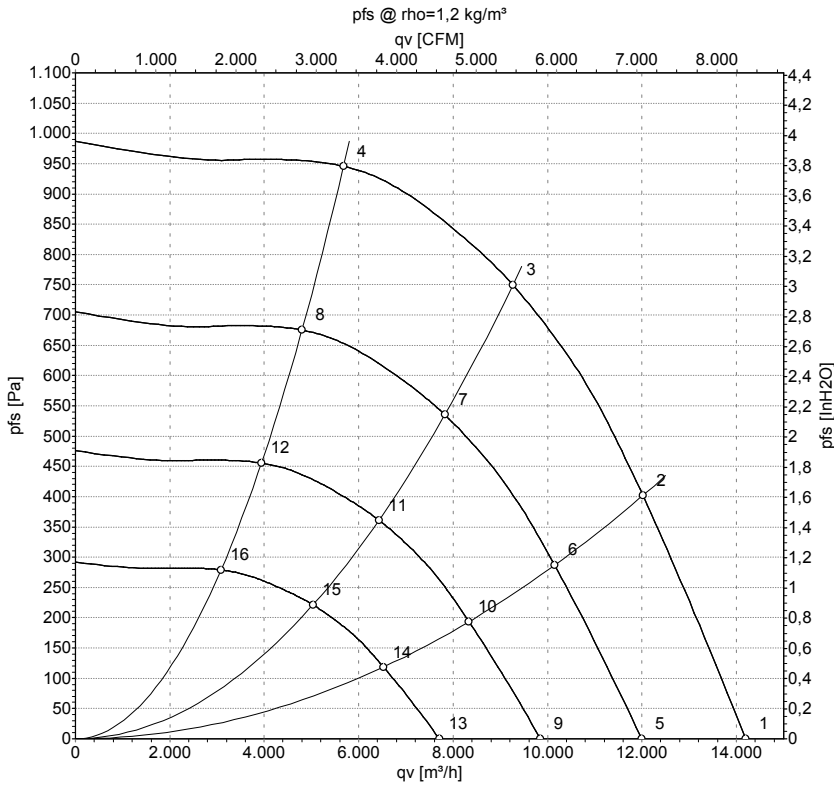

Measurement: LU-145862-1

Air performance measured as per ISO 5801 Installation category A. For detailed information on the measuring set-up, please contact ebmpapst. Suction-side noise levels: LwA measured as per ISO 13347 / LpA measured with 1m distance to fan axis. The values given are valid under the measuring conditions mentioned above and may vary according to the actual installation situation. With any deviation from the standard set-up, the specific values have to be checked and reviewed with the unit installed.

Measured values

	Conn.	U	f	n	P _{ed}	I	LpA _{in}	LwA _{in}	LwA _{out}	q _v	P _{fs}	q _v	P _{fs}
		V	Hz	min ⁻¹	W	A	dB(A)	dB(A)	dB(A)	m ³ /h	Pa	cfm	inH2O
1	Y	400	50	1650	2026	3.03	81	87	90	14200	0	8355	0.00
2	Y	400	50	1650	2686	4.00	74	81	85	12020	400	7075	1.61
3	Y	400	50	1650	2900	4.43	70	77	82	9265	750	5450	3.01
4	Y	400	50	1650	2710	4.03	75	83	86	5680	950	3340	3.81
5	Y	400	50	1400	1220	1.82	76	83	86	11990	0	7055	0.00
6	Y	400	50	1400	1618	2.41	70	77	81	10150	288	5975	1.16
7	Y	400	50	1400	1773	2.63	66	73	78	7825	537	4605	2.16
8	Y	400	50	1400	1634	2.43	70	78	82	4795	679	2825	2.73
9	Y	400	50	1150	676	1.01	71	78	81	9850	0	5795	0.00
10	Y	400	50	1150	897	1.33	65	72	76	8335	194	4905	0.78
11	Y	400	50	1150	983	1.46	61	68	73	6430	362	3785	1.45
12	Y	400	50	1150	906	1.35	66	74	77	3940	458	2320	1.84
13	Y	400	50	900	324	0.48	65	72	75	7710	0	4535	0.00
14	Y	400	50	900	430	0.64	59	66	70	6525	119	3840	0.48
15	Y	400	50	900	471	0.70	55	62	67	5030	222	2960	0.89
16	Y	400	50	900	434	0.65	59	67	71	3085	280	1815	1.12

Conn. = Connection · U = Supply voltage · f = Frequency · n = Speed (rpm) · P_{ed} = Power input · I = Current draw · LpA_{in} = Sound pressure level inlet side · LwA_{in} = Sound power level inlet side
LwA_{out} = Sound power level outlet side · q_v = Air flow · P_{fs} = Pressure increase

