

R3G560-RB31-76 ebmpapst Datasheet

sales@fansco.com

www.fansco.com

Limited partnership · Headquarters Mulfingen

Amtsgericht (court of registration) Stuttgart · HRA 590344

General partner Elektrobau Mulfingen GmbH · Headquarters Mulfingen

Amtsgericht (court of registration) Stuttgart · HRB 590142

Nominal data

Type	R3G560-RB31-76	
Motor	M3G150-IF	
Phase		3~
Nominal voltage	VAC	400
Nominal voltage range	VAC	380 .. 480
Frequency	Hz	50/60
Method of obtaining data		ml
Speed (rpm)	min ⁻¹	1645
Power consumption	W	2900
Current draw	A	4.43
Min. ambient temperature	°C	-25
Max. ambient temperature	°C	55

ml = Max. load · me = Max. efficiency · fa = Free air · cs = Customer specification · ce = Customer equipment
Subject to change

Data according to Commission Regulation (EU) 327/2011

		Actual	Req. 2015			
01 Overall efficiency η_{es}	%	67.9	56.4	09 Power consumption P_{ed}	kW	2.92
02 Measurement category		A		09 Air flow q_v	m ³ /h	9845
03 Efficiency category		Static		09 Pressure increase p_{fs}	Pa	688
04 Efficiency grade N		73.5	62	10 Speed (rpm) n	min ⁻¹	1645
05 Variable speed drive		Yes		11 Specific ratio [*]		1.01

Data obtained at optimum efficiency level.

The ErP data is determined using a motor-impeller combination in a standardized measurement setup.

^{*} Specific ratio = $1 + p_{fs} / 100\,000\text{ Pa}$

LU-162213



Technical description

Weight	26.5 kg
Size	560 mm
Motor size	150
Rotor surface	Painted black
Electronics housing material	Die-cast aluminum
Impeller material	PP plastic (black)
Number of blades	6
Direction of rotation	Clockwise, viewed toward rotor
Degree of protection	IP55
Insulation class	"F"
Moisture (F) / Environmental (H) protection class	H1
Ambient temperature note	Occasional start-up between -40°C and -25°C is permissible. For continuous operation at temperatures below -25°C (e.g. refrigeration applications) we recommend our fan design with special low-temperature bearings.
Max. permitted ambient temp. for motor (transport/storage)	+80 °C
Min. permitted ambient temp. for motor (transport/storage)	-40 °C
Installation position	Shaft horizontal or rotor on bottom; rotor on top on request
Condensation drainage holes	On rotor side
Mode	S1
Motor mounting	Ball bearing
Technical features	<ul style="list-style-type: none"> - Output 10 VDC, max. 10 mA - Operation and alarm display - External 24 V input (parameter setting) - External release input - Alarm relay - Integrated PID controller - Motor current limitation - PFC, passive - RS-485 MODBUS-RTU - Soft start - Control input 0-10 VDC / PWM - Control interface with SELV potential safely disconnected from the mains - Thermal overload protection for electronics/motor - Line undervoltage / phase failure detection
Touch current according to IEC 60990 (measuring circuit Fig. 4, TN system)	<= 3.5 mA
Electrical hookup	Terminal box
Motor protection	Reverse polarity and locked-rotor protection
Protection class	I (if protective earth is connected by customer to the housing's connection point)
Conformity with standards	EN 61800-5-1; CE
Approval	EAC

Product drawing

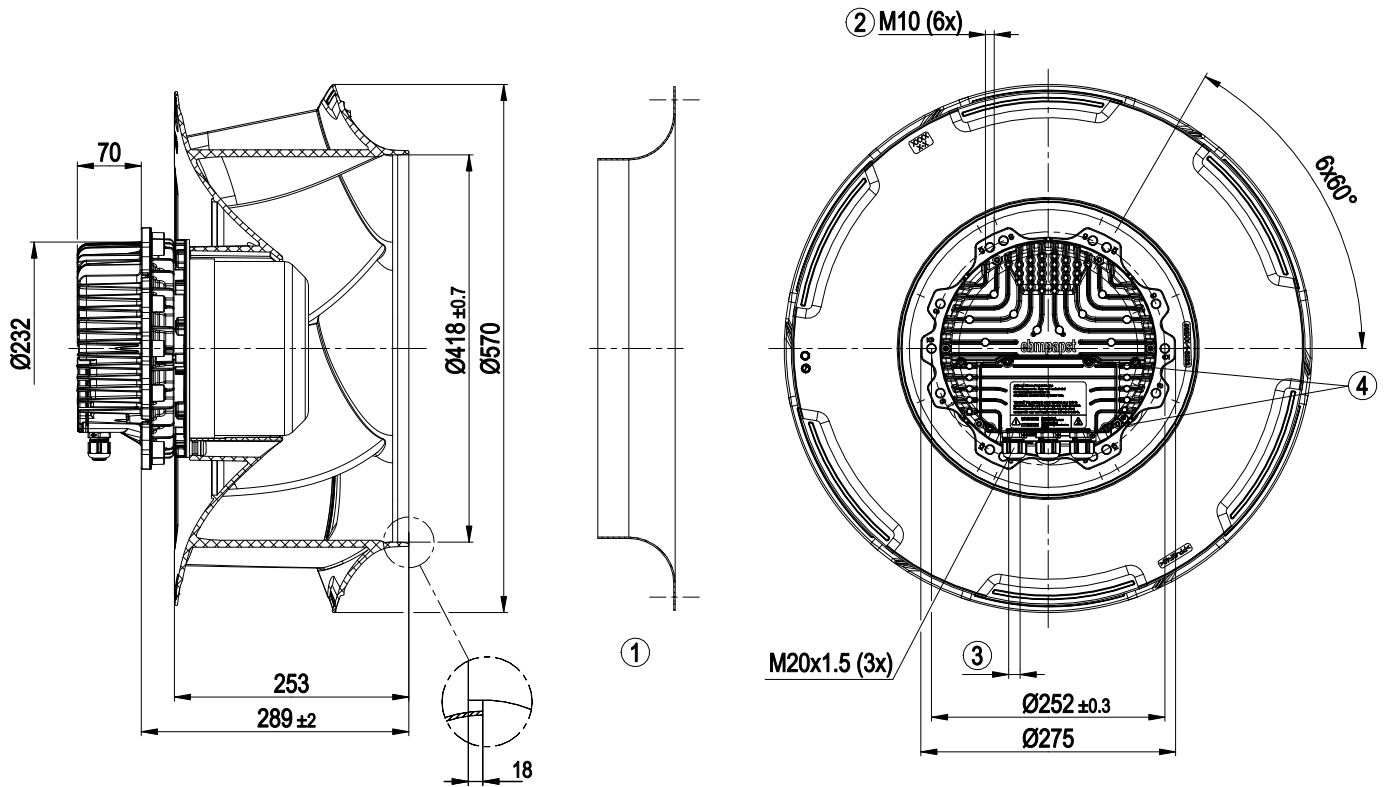

1	Accessory part: inlet ring 54482-2-4013 not included in scope of delivery
2	Max. clearance for screw 25 mm
3	Cable diameter min. 4 mm, max. 10 mm, tightening torque 4 ± 0.6 Nm
4	Tightening torque 3.5 ± 0.5 Nm



Accessory part

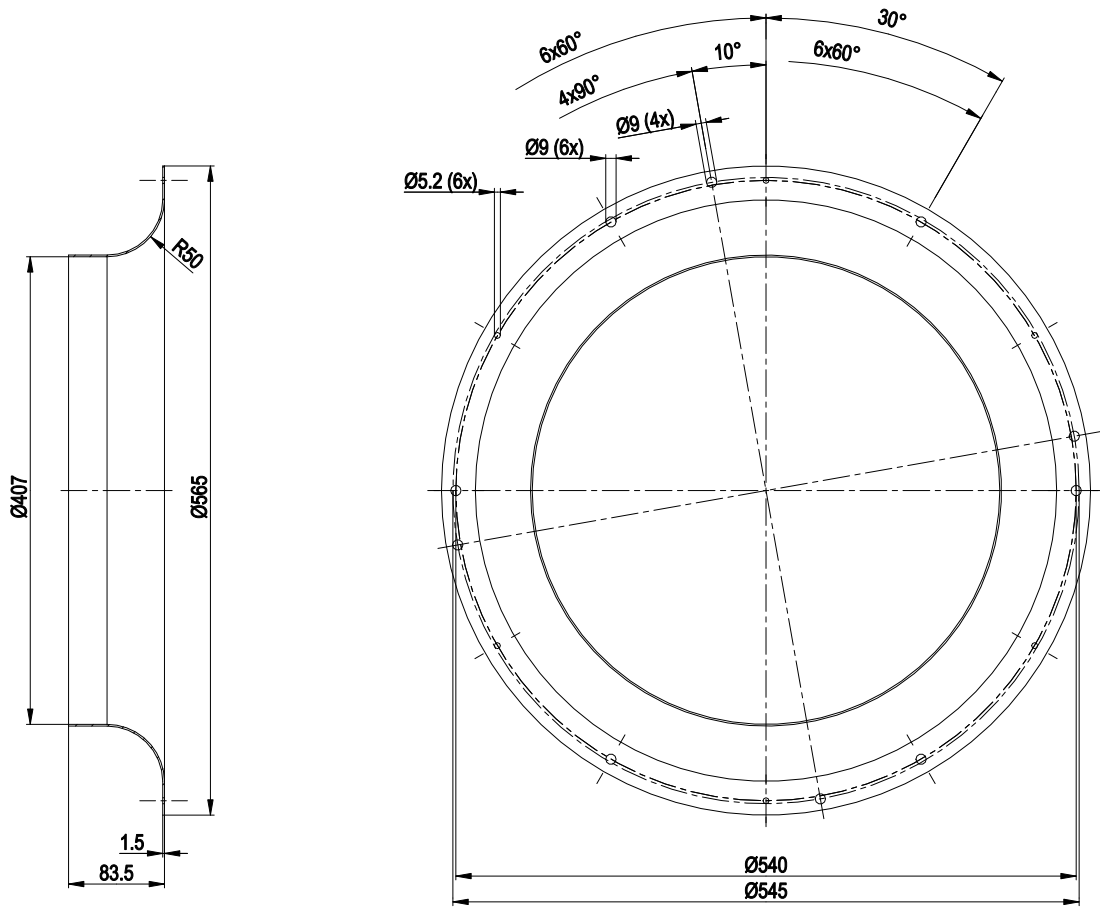

Accessory part: inlet ring 54482-2-4013 not included in scope of delivery



Connection diagram

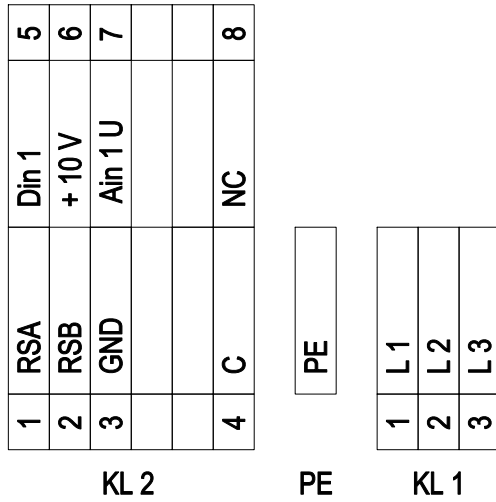

No.	Conn.	Designation	Function/assignment
KL 1	1	L1	Supply connection, power supply 3-phase 380-480 VAC, 50/60 Hz
KL 1	2	L2	Supply connection, power supply 3-phase 380-480 VAC, 50/60 Hz
KL 1	3	L3	Supply connection, power supply 3-phase 380-480 VAC, 50/60 Hz
PE		PE	Ground connection, PE connection
KL 2	1	RSA	Bus connection RS485, RSA, MODBUS-RTU; SELV
KL 2	2	RSB	Bus connection RS485, RSB, MODBUS-RTU; SELV
KL 2	3	GND	Reference ground for control interface; SELV
KL2	4	C	Status relay, floating status contact, break for failure; contact rating 250 VAC / max. 2 A (AC1) / min. 10 mA
KL 2	5	Din1	Digital input 1 enable electronics, enable: pin open or applied voltage 5-50 VDC disable: bridge to GND or applied voltage < 1 VDC reset function: triggers software reset after a level change to < 1 V; SELV
KL 2	6	+ 10 V	Fixed voltage output 10 VDC, +10 V ±3%, max. 10 mA, short-circuit-proof, power supply for external devices (e.g. pot); SELV Or: +24 VDC input for parameter setting via MODBUS without line voltage
KL 2	7	Ain1 U	Analog input 1 (set value) 0-10 V, Ri = 100 kΩ, adjustable curve; SELV
KL2	8	NC	Status relay, floating status contact, break for failure



Curves: Air performance 50 Hz

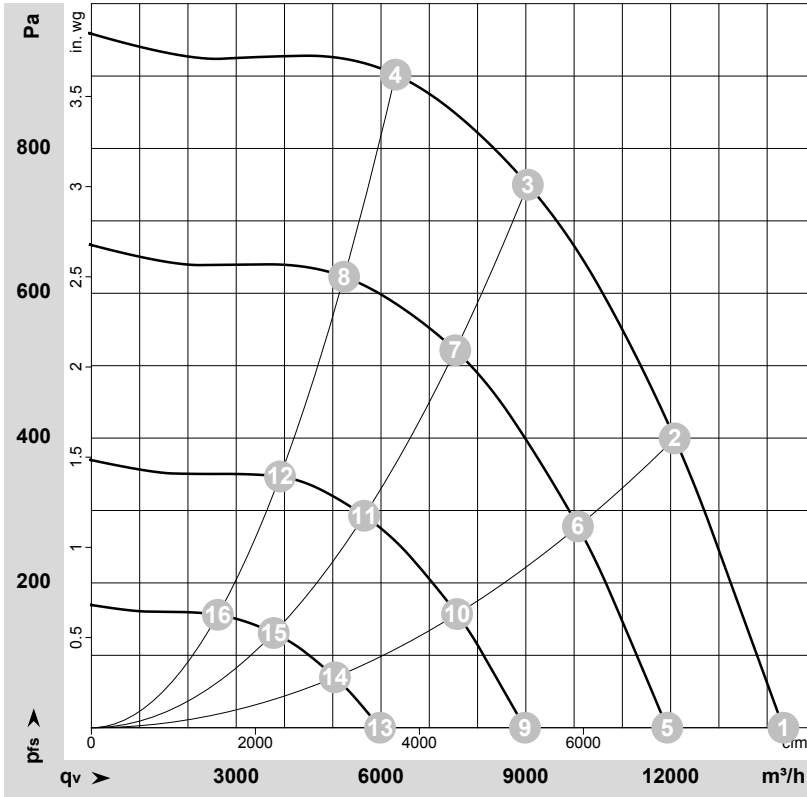

$\rho = 1.15 \text{ kg/m}^3 \pm 2 \%$

Measurement: LU-162213-1

Air performance measured according to ISO 5801 installation category A. For detailed information on the measurement setup, contact ebmpapst. Intake sound level: Sound power level according to ISO 13347 / sound pressure level measured at 1 m distance from fan axis. The values given are valid under the specified measuring conditions and may vary due to conditions of installation. For deviations from the standard configuration, the parameters have to be checked on the installed unit.

Measured values

	Wired	U	f	n	P _{ed}	I	LpA _{in}	LwA _{in}	LwA _{out}	q _v	P _{fs}	q _v	P _{fs}
		V	Hz	min ⁻¹	W	A	dB(A)	dB(A)	dB(A)	m ³ /h	Pa	cfm	in. wg
1	3~	400	50	1645	2030	3.17	79	87	90	14335	0	8440	0.00
2	3~	400	50	1645	2693	4.16	73	81	85	12085	400	7115	1.61
3	3~	400	50	1645	2900	4.43	69	77	82	9040	750	5320	3.01
4	3~	400	50	1645	2774	4.28	73	81	85	6300	900	3710	3.61
5	3~	400	50	1375	1191	1.94	75	83	86	11930	0	7020	0.00
6	3~	400	50	1375	1591	2.52	69	77	81	10080	279	5935	1.12
7	3~	400	50	1375	1705	2.70	64	73	77	7540	521	4435	2.09
8	3~	400	50	1375	1613	2.56	68	76	80	5235	624	3080	2.51
9	3~	400	50	1035	534	1.07	70	77	80	8985	0	5285	0.00
10	3~	400	50	1035	711	1.31	64	71	75	7575	158	4460	0.63
11	3~	400	50	1035	759	1.37	57	66	70	5650	293	3325	1.18
12	3~	400	50	1030	712	1.31	59	68	72	3905	347	2300	1.39
13	3~	400	50	695	189	0.60	61	69	72	5980	0	3520	0.00
14	3~	400	50	695	242	0.67	56	64	66	5045	70	2970	0.28
15	3~	400	50	695	258	0.69	48	56	60	3775	131	2220	0.53
16	3~	400	50	695	244	0.67	48	57	61	2620	156	1540	0.63

Wired = Wiring · U = Power supply · f = Frequency · n = Speed (rpm) · P_{ed} = Power consumption · I = Current draw · LpA_{in} = Sound pressure level intake side · LwA_{in} = Sound power level intake side · LwA_{out} = Sound power level outlet side · q_v = Air flow · P_{fs} = Pressure increase

