

R3G560-PB31-71 ebmpapst Datasheet

sales@fansco.com

www.fansco.com

## Nominal data

Type	R3G560-PB31-71	
Motor	M3G150-IF	
Phase		3~
Nominal voltage	VAC	400
Nominal voltage range	VAC	380 .. 480
Frequency	Hz	50/60
Type of data definition		ml
Speed (rpm)	min <sup>-1</sup>	1540
Power input	W	3300
Current draw	A	5.1
Min. ambient temperature	°C	-25
Max. ambient temperature	°C	50

ml = Max. load · me = Max. efficiency · fa = Running at free air · cs = Customer specs · cu = Customer unit  
Subject to alterations

## Data in accordance with ecodesign regulation EU 327/2011

		Actual	Request 2015			
01 Overall efficiency $\eta_{es}$	%	71	56.9	09 Power input $P_{ed}$	kW	3.29
02 Measurement category		A		09 Air flow $q_v$	m <sup>3</sup> /h	10515
03 Efficiency category		Static		09 Pressure increase $p_{fs}$	Pa	759
04 Efficiency grade N		76.1	62	10 Speed (rpm) n	min <sup>-1</sup>	1535
05 Variable speed drive		Yes		11 Specific ratio <sup>*</sup>		1.01

Data definition with optimum efficiency.

The ErP data is determined using a motor-impeller combination in a standardised measurement configuration.

<sup>\*</sup> Specific ratio =  $1 + p_{fs} / 100\,000\text{ Pa}$

LU-173841



### Technical features

Mass	30.5 kg
Size	560 mm
Surface of rotor	Coated in black
Material of electronics housing	Die-cast aluminium
Material of impeller	Aluminium sheet
Number of blades	5
Direction of rotation	Clockwise, seen on rotor
Type of protection	IP 55
Insulation class	"F"
Humidity (F)/environmental protection class (H)	H1
Max. permissible ambient motor temp. (transp./ storage)	+80 °C
Min. permissible ambient motor temp. (transp./storage)	-40 °C
Mounting position	Shaft horizontal or rotor on bottom; rotor on top on request
Condensate discharge holes	Rotor-side
Operation mode	S1
Motor bearing	Ball bearing
Technical features	<ul style="list-style-type: none"> <li>- Output 10 VDC, max. 10 mA</li> <li>- Operation and alarm display</li> <li>- External 24 V input (programming)</li> <li>- External release input</li> <li>- Alarm relay</li> <li>- Integrated PID controller</li> <li>- Motor current limit</li> <li>- PFC, passive</li> <li>- RS485 MODBUS RTU</li> <li>- Soft start</li> <li>- Control input 0-10 VDC / PWM</li> <li>- Control interface with SELV potential safely disconnected from the mains</li> <li>- Over-temperature protected electronics / motor</li> <li>- Line undervoltage / phase failure detection</li> </ul>
EMC interference immunity	Acc. to EN 61000-6-2 (industrial environment)
EMC interference emission	Acc. to EN 61000-6-3 (household environment), except EN 61000-3-2 for professionally used devices with a total rated power greater than 1 kW
Touch current acc. IEC 60990 (measuring network Fig. 4, TN system)	<= 3.5 mA
Electrical leads	Via terminal box
Motor protection	Reverse polarity and locked-rotor protection
Protection class	I (if protective earth is connected by customer)
Product conforming to standard	EN 61800-5-1; CE
Approval	EAC

Product drawing

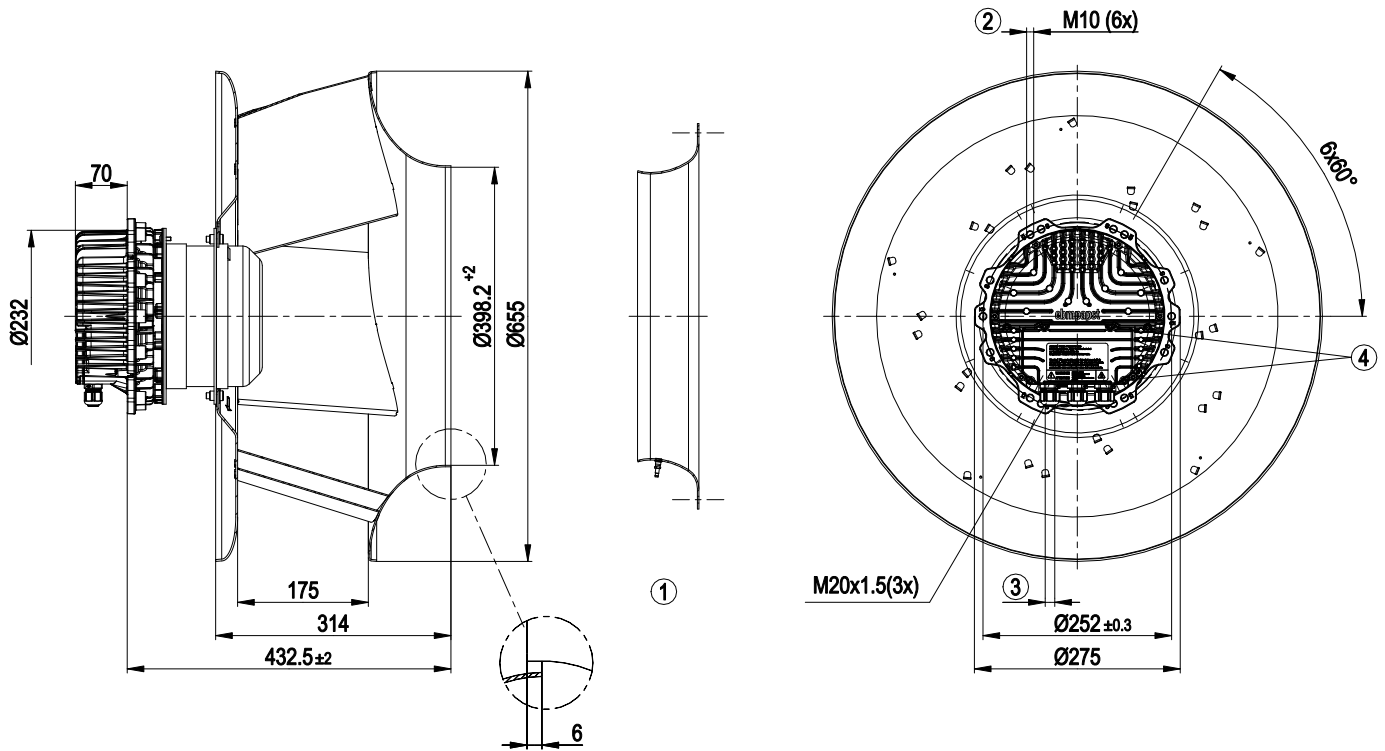

1	Accessory part: inlet nozzle 64030-2-4013 with pressure tap (k-factor: 348) not included in scope of delivery
2	Thread reach max. 25 mm
3	Cable diameter min. 4 mm, max. 10 mm, tightening torque $4 \pm 0.6$ Nm
4	Tightening torque $3.5 \pm 0.5$ Nm



## Accessory part

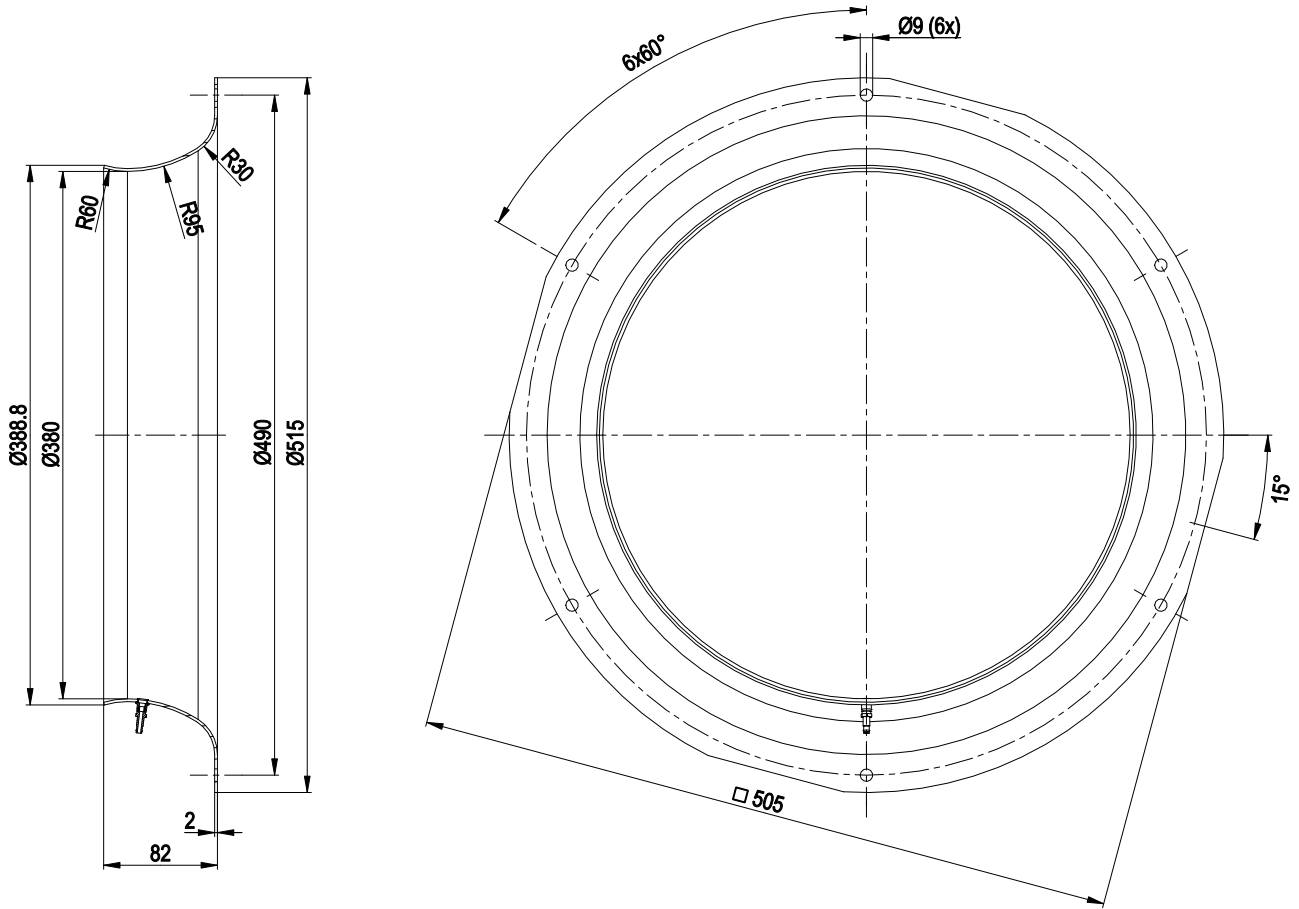

Inlet nozzle 64030-2-4013 with pressure tap not included in scope of delivery



## Connection screen

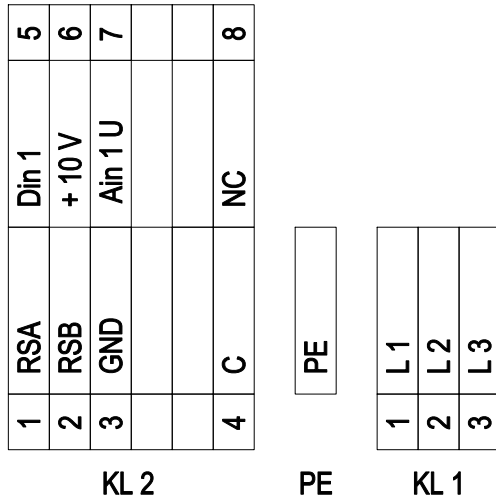

No.	Conn.	Designation	Function / assignment
KL 1	1	L1	Mains supply connection, supply voltage 3~380-480 VAC; 50/60 Hz
KL 1	2	L2	Mains supply connection, supply voltage 3~380-480 VAC; 50/60 Hz
KL 1	3	L3	Mains supply connection, supply voltage 3~380-480 VAC; 50/60 Hz
PE		PE	Earth connection, PE connection
KL 2	1	RSA	Bus connection RS-485, RSA, MODBUS RTU; SELV
KL 2	2	RSB	Bus connection RS-485, RSB, MODBUS RTU; SELV
KL 2	3	GND	Signal ground for control interface; SELV
KL2	4	C	Status relay; floating status contact; break for failure; contact rating 250 VAC / max. 2 A (AC1) / min. 10 mA
KL 2	5	Din1	Digital input 1 enabling of electronics, enabling: open pin or applied voltage 5-50 VDC disabling: bridge to GND or applied voltage <1 VDC reset function: triggers software reset after a level change to <1 V; SELV
KL 2	6	+ 10 V	Fixed voltage output 10 VDC; +10 V -3 %, max. 10 mA, short-circuit-proof, power supply for external devices (e.g. potentiometer); SELV Alternative: +24 VDC input for parametrisation via MODBUS without mains power
KL 2	7	Ain1 U	Analogue input 1 (set value) 0-10 V, Ri=100 kΩ, parametrisable curve; SELV
KL2	8	NC	Status relay, floating status contact; break for failure



## Charts: Air flow 50 Hz

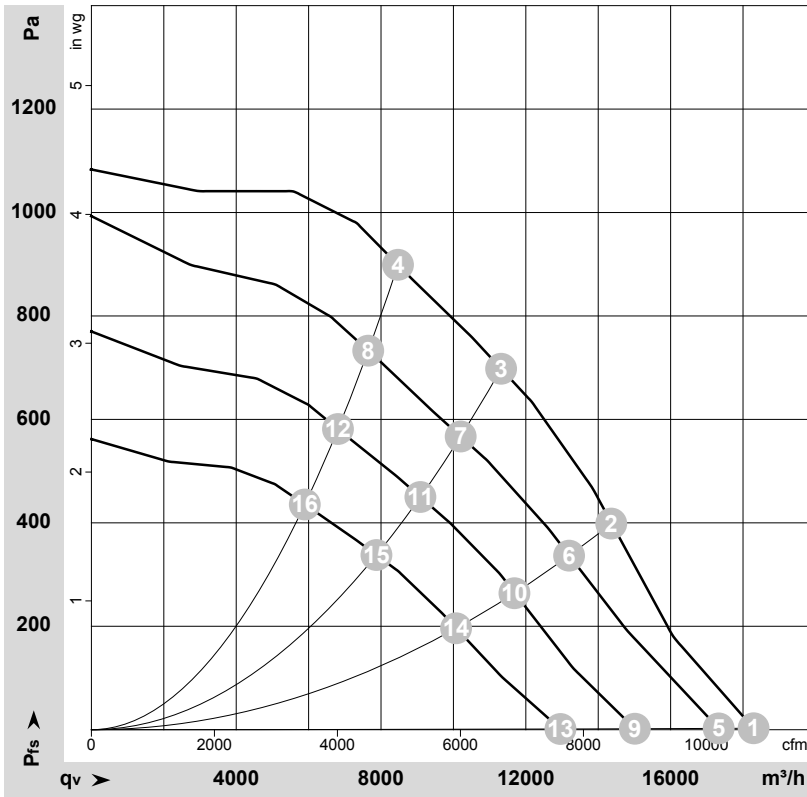

$\rho = 1.15 \text{ kg/m}^3 \pm 2 \%$

Measurement: LU-173841-1

Air performance measured as per ISO 5801 Installation category A. For detailed information on the measuring set-up, please contact ebmpapst. Suction-side noise levels: LwA measured as per ISO 13347 / LpA measured with 1m distance to fan axis. The values given are valid under the measuring conditions mentioned above and may vary according to the actual installation situation. With any deviation from the standard set-up, the specific values have to be checked and reviewed with the unit installed.

## Measured values

	U	f	n	P <sub>ed</sub>	I	LpA <sub>in</sub>	LwA <sub>in</sub>	LwA <sub>out</sub>	q <sub>v</sub>	P <sub>fs</sub>	q <sub>v</sub>	P <sub>fs</sub>
	V	Hz	min <sup>-1</sup>	W	A	dB(A)	dB(A)	dB(A)	m <sup>3</sup> /h	Pa	cfm	in. wg
1	400	50	1540	1834	2.88	91	97	97	18290	0	10765	0.00
2	400	50	1540	2810	4.32	81	88	90	14360	400	8450	1.61
3	400	50	1540	3300	5.10	76	82	86	11320	700	6665	2.81
4	400	50	1540	3230	4.95	76	82	86	8470	900	4985	3.61
5	400	50	1470	1591	2.52	89	96	95	17325	0	10200	0.00
6	400	50	1410	2168	3.37	80	86	88	13195	337	7765	1.35
7	400	50	1385	2389	3.70	71	79	82	10200	567	6005	2.28
8	400	50	1385	2372	3.68	71	78	82	7645	733	4500	2.94
9	400	50	1275	1059	1.77	86	93	93	15015	0	8835	0.00
10	400	50	1250	1524	2.43	75	83	85	11685	265	6880	1.06
11	400	50	1235	1699	2.69	69	75	80	9085	450	5350	1.81
12	400	50	1235	1684	2.66	69	75	80	6810	581	4010	2.33
13	400	50	1110	714	1.31	82	89	90	12955	0	7625	0.00
14	400	50	1080	1001	1.69	72	79	82	10075	196	5930	0.79
15	400	50	1070	1116	1.85	65	72	77	7875	338	4635	1.36
16	400	50	1070	1101	1.83	65	72	77	5895	436	3470	1.75

U = Supply voltage · f = Frequency · n = Speed (rpm) · P<sub>ed</sub> = Power input · I = Current draw · LpA<sub>in</sub> = Sound pressure level inlet side · LwA<sub>in</sub> = Sound power level inlet side · LwA<sub>out</sub> = Sound power level outlet side  
 q<sub>v</sub> = Air flow · P<sub>fs</sub> = Pressure increase

