

R3G560-PB31-10 ebmpapst Datasheet

sales@fansco.com

www.fansco.com

Limited partnership · Headquarters Mulfingen

Amtsgericht (court of registration) Stuttgart · HRA 590344

General partner Elektrobau Mulfingen GmbH · Headquarters Mulfingen

Amtsgericht (court of registration) Stuttgart · HRB 590142

Nominal data

| | | |
|--------------------------|-------------------|------------|
| Type | R3G560-PB31-10 | |
| Motor | M3G150-IF | |
| Phase | | 3~ |
| Nominal voltage | VAC | 400 |
| Nominal voltage range | VAC | 380 .. 480 |
| Frequency | Hz | 50/60 |
| Method of obtaining data | | ml |
| Status | | prelim. |
| Speed (rpm) | min ⁻¹ | 1495 |
| Power consumption | W | 3100 |
| Current draw | A | 4.7 |
| Min. ambient temperature | °C | -40 |
| Max. ambient temperature | °C | 60 |

ml = Max. load · me = Max. efficiency · fa = Free air · cs = Customer specification · ce = Customer equipment
Subject to change

Data according to Commission Regulation (EU) 327/2011 (EN 17166)

| | | Actual | Req. 2015 | | | |
|-----------------------------------|---|--------|-----------|--------------------------------|-------------------|-------|
| 01 Overall efficiency η_{es} | % | 68.5 | 56.6 | 09 Power consumption P_{ed} | kW | 3.08 |
| 02 Measurement category | | A | | 09 Air flow q_v | m ³ /h | 10295 |
| 03 Efficiency category | | Static | | 09 Pressure increase p_{fs} | Pa | 703 |
| 04 Efficiency grade N | | 73.9 | 62 | 10 Speed (rpm) n | min ⁻¹ | 1500 |
| 05 Variable speed drive | | Yes | | 11 Specific ratio [*] | | 1.01 |

Data obtained at optimum efficiency level.

^{*} Specific ratio = $1 + p_{fs} / 100\,000\text{ Pa}$

LU-210632

The efficiency values displayed for achieving conformity with the Ecodesign Regulation EU 327/2011 has been reached with defined air duct components (e.g. inlet rings).

The dimensions must be requested from ebm-papst. If other air conduction geometries are used on the installation side, the ebm-papst evaluation loses its validity/the conformity must be confirmed again.

The product does not fall within the scope of Regulation (EU) 2019/1781 due to the exception specified in Article 2 (2a) (motors completely integrated into a product).



Technical description

| | |
|--|--|
| Size | 560 mm |
| Motor size | 150 |
| Rotor surface | Painted black |
| Electronics housing material | Die-cast aluminum |
| Impeller material | Sheet aluminum |
| Number of blades | 5 |
| Direction of rotation | Clockwise, viewed toward rotor |
| Degree of protection | IP55 |
| Insulation class | "F" |
| Moisture (F) / Environmental (H) protection class | H1 |
| Ambient temperature note | Occasional start-up at temperatures between -40°C and -25°C is permitted. For continuous operation at ambient temperatures below -25°C (such as refrigeration applications), use must be made of a fan design with special low-temperature bearings. |
| Max. permitted ambient temp. for motor (transport/storage) | +80 °C |
| Min. permitted ambient temp. for motor (transport/storage) | -40 °C |
| Installation position | Shaft horizontal or rotor on bottom; rotor on top on request |
| Condensation drainage holes | On rotor side |
| Mode | S1 |
| Motor bearing | Ball bearing |
| Technical features | <ul style="list-style-type: none"> - Operation and alarm display with LED - External 15-50 VDC input (parameterization) - Alarm relay - Integrated PI controller - Configurable inputs/outputs (I/O) - MODBUS V6.3 - Motor current limitation - RFID - ISO 15693 compatible - RS-485 MODBUS-RTU - Soft start - Voltage output 3.3-24 VDC, Pmax = 800 mW - Control interface with SELV potential safely disconnected from the mains - Thermal overload protection for electronics/motor - Line undervoltage / phase failure detection |
| EMC immunity to interference | According to EN 61000-6-2 (industrial environment) |
| EMC interference emission | According to EN 61000-6-3 (household environment), except EN 61000-3-2 for professionally used equipment with a total rated power greater than 1 kW |
| Touch current according to IEC 60990 (measuring circuit Fig. 4, TN system) | <= 3.5 mA |
| Electrical hookup | Terminal box |
| Motor protection | Reverse polarity and locked-rotor protection |
| Protection class | I (with customer connection of protective earth) |
| Conformity with standards | EN 61800-5-1; CE |
| Approval | CSA C22.2 No. 77 + CAN/CSA-E60730-1; EAC; UL 1004-7 + 60730-1 |

Product drawing

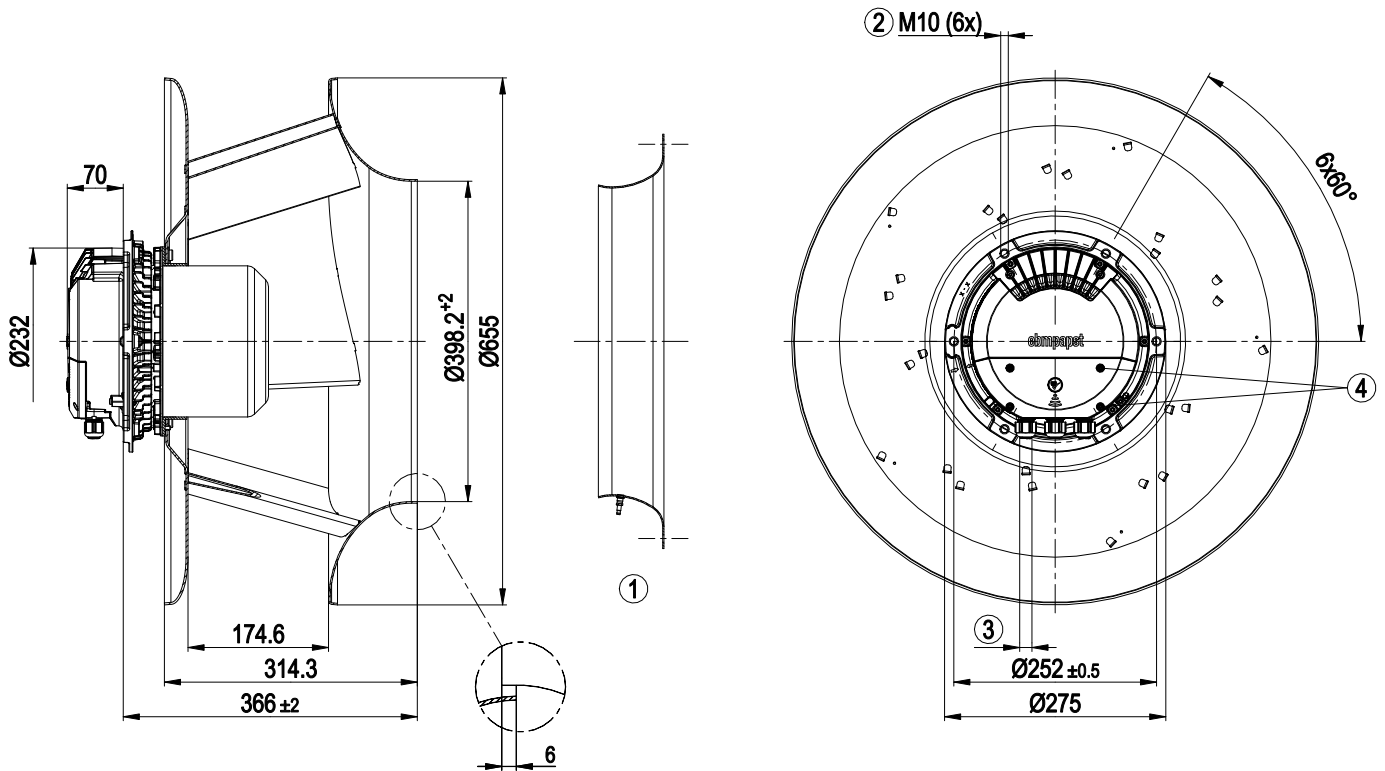

| | |
|---|---|
| 1 | Accessory part: Inlet ring 64030-2-4013 with pressure tap (k-factor: 348) not included in scope of delivery |
| 2 | Max. clearance for screw 20 mm |
| 3 | Cable diameter min. 4 mm, max. 10 mm, tightening torque 4 ± 0.6 Nm (The tightening torque is designed for PVC cables. If the cable materials are different, the tightening torque may have to be adjusted) |
| 4 | Tightening torque 1.5 ± 0.2 Nm |

Accessory part

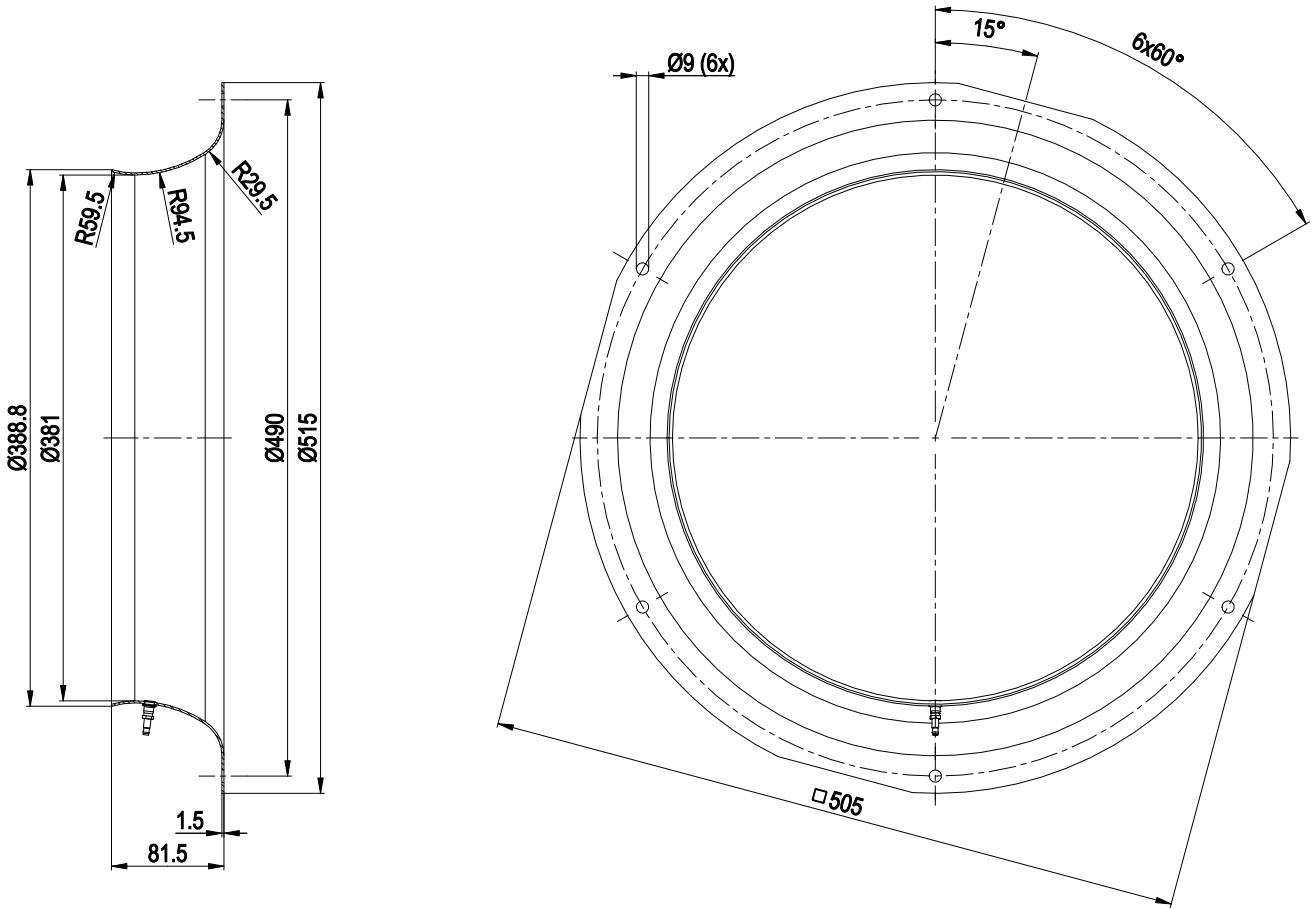

Inlet ring 64030-2-4013 with pressure tap (k-factor: 348)



Connection diagram

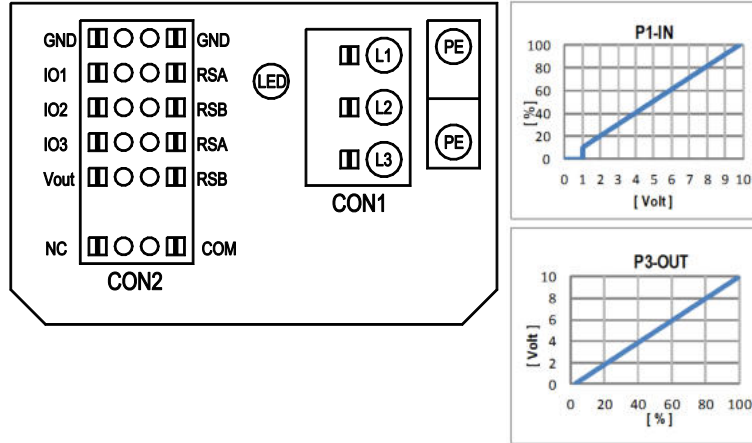

| No. | Conn. | Designation | Function/assignment |
|-----|-------|-------------|---|
| | CON1 | L1, L2, L3 | Power supply, phase, see nameplate for voltage range |
| | PE | PE | Protective earth |
| | CON2 | RSA | RS485 interface for MODBUS, RSA; SELV |
| | CON2 | RSB | RS485 interface for MODBUS, RSB; SELV |
| | CON2 | GND | Reference ground for control interface, SELV |
| | CON2 | IO1 | Function parameterizable (see "Optional interface functions" table) Factory setting: Digital input - high active, function: Disable input, SELV - inactive: Pin open or applied voltage < 1.5 VDC - active: applied voltage 3.5-50 VDC Reset function: Triggering of error reset on change of state from "enabled" to "disabled" |
| | CON2 | IO2 | Function parameterizable (see "Optional interface functions" table) Factory setting: Analog input 0-10 V / PWM, Ri=100 kΩ, function: Set value Characteristic curve parameterizable (see input characteristic curve P1-IN), SELV |
| | CON2 | IO3 | Function parameterizable (see "Optional interface functions" table) Factory setting: Analog output 0-10 V, max. 5 mA, function: Fan modulation level Characteristic curve parameterizable (see output characteristic curve P3-OUT), SELV |
| | CON2 | Vout | Voltage output 3.3-24 VDC ±5%, Pmax=800 mW, voltage parameterizable Factory setting: 10 VDC short-circuit-proof, supply for external devices, SELV alternatively: 15-50 VDC input for parameterization via MODBUS without line voltage |
| | CON2 | COM | Status relay, floating status contact, common connection, contact rating 250 VAC / 2 A (AC1) / min. 10 mA, reinforced insulation on supply side and on control interface side |
| | CON2 | NC | Status relay, floating status contact, break for failure |
| | | LED | green: status = good, ready for operation orange: status = warning red: status = failure |
| | | P1-IN | Input characteristic curve |
| | | P3-OUT | Output characteristic curve |



Terminal/plug assignment

| CON2 | configurable IO mode | electrical specification | configurable IO functions: normal / inverse | MODBUS Register for IO mode configuration | |
|------|--|---|---|---|---|
| | | | | MODBUS Register for IO mode configuration | MODBUS Register for IO mode configuration |
| IO1 | ○ Din1 (active high), digital input | active: applied voltage 3.5-50VDC, SELV not active: pin open or applied voltage < 1.5VDC | D158 [0] | switch: fan enable / disable | D16A [..] |
| | ○ Ain1 0-10V/PWM: analog input | RI = 100k, characteristic curve parameterizable, $f_{PWM} = 1k..10kHz$, SELV | D158 [2] | switch: set value source | D16C [..] |
| | ○ Tach out (open collector output) | Umax = 50VDC, Imax = 20mA, SELV | D158 [5] | switch: direction of rotation: cw / ccw | D148 [..] |
| | ○ Diagnostics out (open collector output) | Umax = 50VDC, Imax = 20mA, SELV | D158 [6] | switch: control function: heating (pos.) / cooling (neg.) | D12E [..] |
| IO2 | ○ Din2 (active high), digital input | active: applied voltage 3.5-50VDC, SELV not active: pin open or applied voltage < 1.5VDC | D159 [0] | switch: parameter set: #1 / #2 | D104 [..] |
| | ○ Ain2 0-10V/PWM: analog input | RI = 100k, characteristic curve parameterizable, $f_{PWM} = 1k..10kHz$, SELV | D159 [2] | source: sensor value | D147 [..] |
| | ○ Ain2 4-20mA: analog input | RI = 125R, characteristic curve parameterizable, SELV | D159 [3] | source: set value | D101 [..] |
| | ○ Din3 (active high), digital input | active: applied voltage 3.5-50VDC, SELV not active: pin open or applied voltage < 1.5VDC | D15A [0] | | |
| IO3 | ○ Din3 (active low), digital input | active: applied voltage < 1.5VDC, SELV not active: pin open or applied voltage 3.5-50VDC | D15A [1] | | |
| | ○ PWMIn3: digital input, idle level high | PWM = 40Hz - 10kHz, characteristics parameterizable | D15A [7] | | |
| | ○ PWMIn3: digital input, idle level low | active: pin open or applied voltage 3.5-50VDC not active: applied voltage < 1.5VDC, SELV | D15A [8] | | |
| | ○ Aout3 0-10V: analog output | function parameterizable, max. 5mA max output frequency 300Hz SELV | D15A [4] | | |
| RSA | ○ Tacho out (pulses), analog output | 0-10V/max. 5mA max output frequency 300Hz SELV | D15A [5] | | |
| | ○ Diagnostics out (pulses) | 0-10V/max. 5mA max output frequency 300Hz, SELV | D15A [6] | | |
| | ○ Diagnostics out (pulses) | MODBUS RTU, specification V6.3, SELV | | | |
| RSB | RS485 bus connection, | | | | |
| Vout | voltage output | voltage parameterizable 3.3..24VDC +/- 5%, Pmax=600mW, short-circuit-proof, supply for external devices, SELV | D16E [..] | | |
| | alternatively: Input auxiliary power supply for parameterization via RS485/MODBUS RTU without line voltage | 15..50VDC | | | |

○ configurable option

For further information and additional functions see EC Control Software, Fan-Set-App, or MODBUS Parameter Specification V6.3



Curves: Air performance 50 Hz

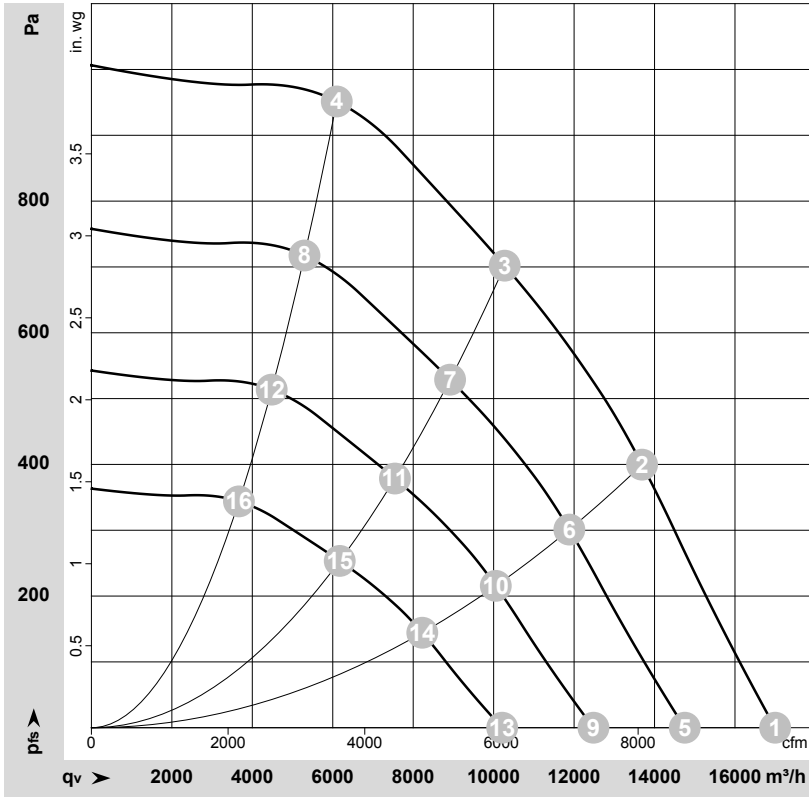

$\rho = 1.15 \text{ kg/m}^3 \pm 2 \%$

Measurement: LU-210632-1

Air performance measured according to ISO 5801 installation category A. For detailed information on the measurement setup, contact ebmpapst. Intake sound level: Sound power level according to ISO 13347 / sound pressure level measured at 1 m distance from fan axis. The values given are valid under the specified measuring conditions and may vary due to conditions of installation. For deviations from the standard configuration, the parameters have to be checked on the installed unit.

Measured values

| | Wired | U | f | n | P _{ed} | I | LpA _{in} | LwA _{in} | LwA _{out} | q _v | p _{fs} | q _v | p _{fs} |
|----|-------|-----|----|-------------------|-----------------|------|-------------------|-------------------|--------------------|-------------------|-----------------|----------------|-----------------|
| | | V | Hz | min ⁻¹ | W | A | dB(A) | dB(A) | dB(A) | m ³ /h | Pa | cfm | in. wg |
| 1 | 3~ | 400 | 50 | 1495 | 1827 | 2.87 | 93 | 99 | 98 | 17000 | 0 | 10005 | 0.00 |
| 2 | 3~ | 400 | 50 | 1495 | 2701 | 4.16 | 80 | 87 | 89 | 13690 | 400 | 8060 | 1.61 |
| 3 | 3~ | 400 | 50 | 1495 | 3100 | 4.70 | 73 | 80 | 84 | 10275 | 700 | 6050 | 2.81 |
| 4 | 3~ | 400 | 50 | 1495 | 2807 | 4.32 | 75 | 83 | 88 | 6100 | 950 | 3590 | 3.81 |
| 5 | 3~ | 400 | 50 | 1300 | 1194 | 1.87 | 89 | 95 | 95 | 14750 | 0 | 8680 | 0.00 |
| 6 | 3~ | 400 | 50 | 1300 | 1765 | 2.72 | 77 | 84 | 85 | 11880 | 305 | 6995 | 1.22 |
| 7 | 3~ | 400 | 50 | 1300 | 2013 | 3.08 | 69 | 76 | 81 | 8915 | 530 | 5250 | 2.13 |
| 8 | 3~ | 400 | 50 | 1300 | 1838 | 2.83 | 72 | 79 | 84 | 5295 | 717 | 3120 | 2.88 |
| 9 | 3~ | 400 | 50 | 1100 | 723 | 1.14 | 85 | 91 | 91 | 12480 | 0 | 7345 | 0.00 |
| 10 | 3~ | 400 | 50 | 1100 | 1069 | 1.65 | 73 | 80 | 81 | 10055 | 218 | 5920 | 0.88 |
| 11 | 3~ | 400 | 50 | 1100 | 1220 | 1.87 | 65 | 72 | 77 | 7545 | 379 | 4440 | 1.52 |
| 12 | 3~ | 400 | 50 | 1100 | 1113 | 1.71 | 67 | 75 | 80 | 4480 | 514 | 2640 | 2.06 |
| 13 | 3~ | 400 | 50 | 900 | 396 | 0.62 | 80 | 86 | 85 | 10215 | 0 | 6010 | 0.00 |
| 14 | 3~ | 400 | 50 | 900 | 586 | 0.90 | 68 | 75 | 76 | 8225 | 146 | 4840 | 0.59 |
| 15 | 3~ | 400 | 50 | 900 | 668 | 1.02 | 60 | 67 | 72 | 6175 | 254 | 3635 | 1.02 |
| 16 | 3~ | 400 | 50 | 900 | 610 | 0.94 | 62 | 70 | 75 | 3665 | 344 | 2160 | 1.38 |

Wired = Wiring · U = Voltage · f = Frequency · n = Speed (rpm) · P_{ed} = Power consumption · I = Current draw · LpA_{in} = Sound pressure level intake side · LwA_{in} = Sound power level intake side · LwA_{out} = Sound power level outlet side · q_v = Air flow · p_{fs} = Pressure increase

