



R3G560-AQ04-06 ebmpapst Datasheet

sales@fansco.com

www.fansco.com

Limited partnership · Headquarters Mulfingen

Amtsgericht (court of registration) Stuttgart · HRA 590344

General partner Elektrobau Mulfingen GmbH · Headquarters Mulfingen

Amtsgericht (court of registration) Stuttgart · HRB 590142

### Nominal data

Type	R3G560-AQ04-06	
Motor	M3G150-NA	
Phase		3~
Nominal voltage	VAC	400
Nominal voltage range	VAC	380 .. 480
Frequency	Hz	50/60
Method of obtaining data		ml
Speed (rpm)	min <sup>-1</sup>	1750
Power consumption	W	5030
Current draw	A	6.1
Min. ambient temperature	°C	-25
Max. ambient temperature	°C	40

ml = Max. load · me = Max. efficiency · fa = Free air · cs = Customer specification · ce = Customer equipment  
Subject to change

### Data according to Commission Regulation (EU) 327/2011

		Actual	Req. 2015
01 Overall efficiency $\eta_{es}$	%	67.2	58.5
02 Measurement category		A	
03 Efficiency category		Static	
04 Efficiency grade N		70.7	62
05 Variable speed drive		Yes	

Data obtained at optimum efficiency level.

The ErP data is determined using a motor-impeller combination in a standardized measurement setup.

09 Power consumption $P_{ed}$	kW	4.67
09 Air flow $q_v$	m <sup>3</sup> /h	11640
09 Pressure increase $p_{fs}$	Pa	934
10 Speed (rpm) $n$	min <sup>-1</sup>	1765
11 Specific ratio*		1.01

\* Specific ratio =  $1 + p_{fs} / 100\,000\text{ Pa}$ 

LU-128639



## Technical description

Weight	40 kg
Size	560 mm
Motor size	150
Rotor surface	Painted black
Electronics housing material	Die-cast aluminum
Impeller material	Sheet aluminum
Number of blades	7
Direction of rotation	Clockwise, viewed toward rotor
Degree of protection	IP55
Insulation class	"F"
Moisture (F) / Environmental (H) protection class	H1
Max. permitted ambient temp. for motor (transport/storage)	+80 °C
Min. permitted ambient temp. for motor (transport/storage)	-40 °C
Installation position	Shaft horizontal or rotor on bottom; rotor on top on request
Condensation drainage holes	On rotor side
Mode	S1
Motor bearing	Ball bearing
Technical features	<ul style="list-style-type: none"> <li>- Output 10 VDC, max. 10 mA</li> <li>- Output 20 VDC, max. 50 mA</li> <li>- Output for slave 0-10 V</li> <li>- Input for sensor 0-10 V or 4-20 mA</li> <li>- External 24 V input (parameter setting)</li> <li>- External release input</li> <li>- Alarm relay</li> <li>- Integrated PID controller</li> <li>- Motor current limitation</li> <li>- PFC, passive</li> <li>- RS-485 MODBUS-RTU</li> <li>- Soft start</li> <li>- EEPROM write cycles: 100,000 maximum</li> <li>- Control input 0-10 VDC / PWM</li> <li>- Control interface with SELV potential safely disconnected from the mains</li> <li>- Thermal overload protection for electronics/motor</li> <li>- Line undervoltage / phase failure detection</li> </ul>
Touch current according to IEC 60990 (measuring circuit Fig. 4, TN system)	<= 3.5 mA
Electrical hookup	Terminal box
Motor protection	Reverse polarity and locked-rotor protection
Protection class	I (with customer connection of protective earth)
Conformity with standards	EN 61800-5-1; CE
Approval	UL 1004-7 + 60730; CSA C22.2 No. 77 + CAN/CSA-E60730-1

Product drawing

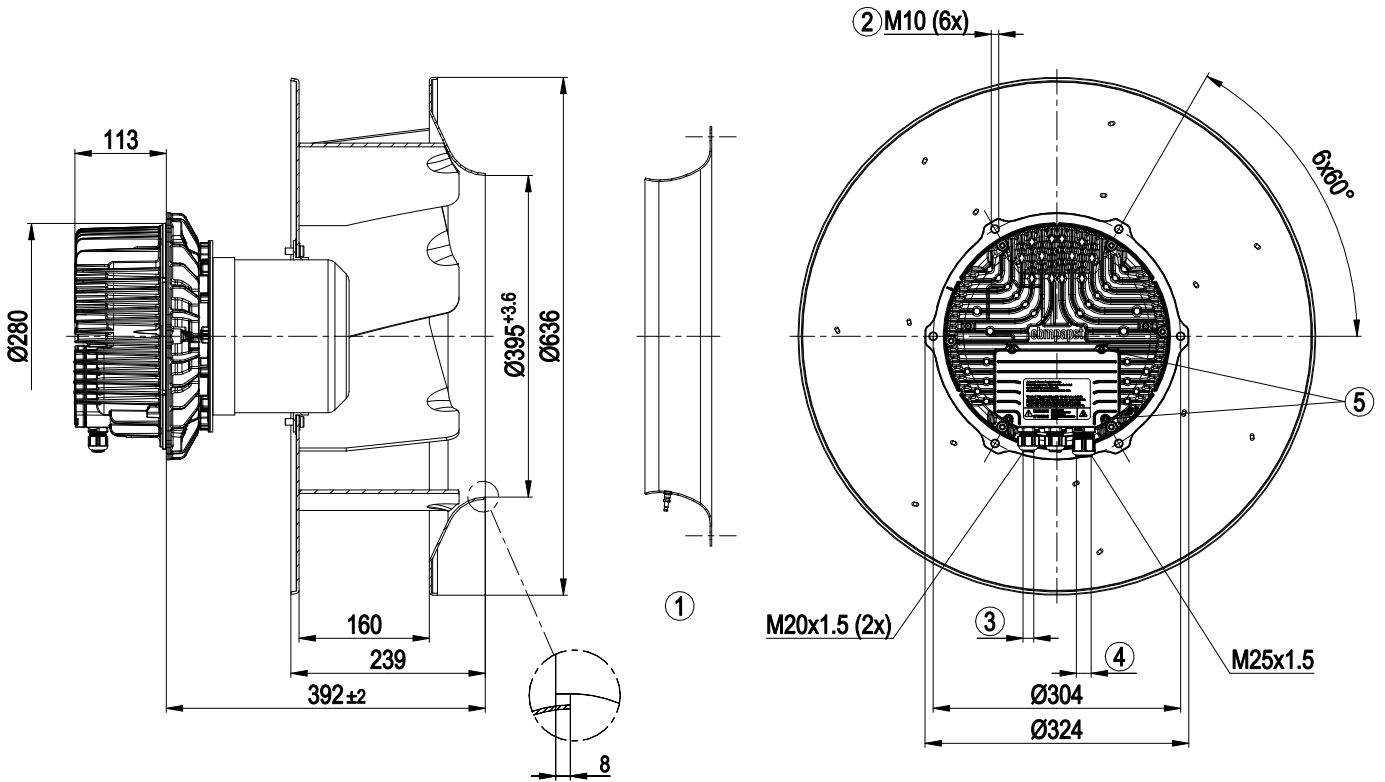

1	Accessory part: Inlet ring 64030-2-4013 with pressure tap (k-factor: 348) not included in scope of delivery
2	Max. clearance for screw 20 mm
3	Cable diameter min. 4 mm, max. 10 mm; tightening torque 4±0.6 Nm
4	Cable diameter min. 9 mm, max. 16 mm; tightening torque 6±0.9 Nm
5	Tightening torque 3.5 ± 0.5 Nm



## Accessory part

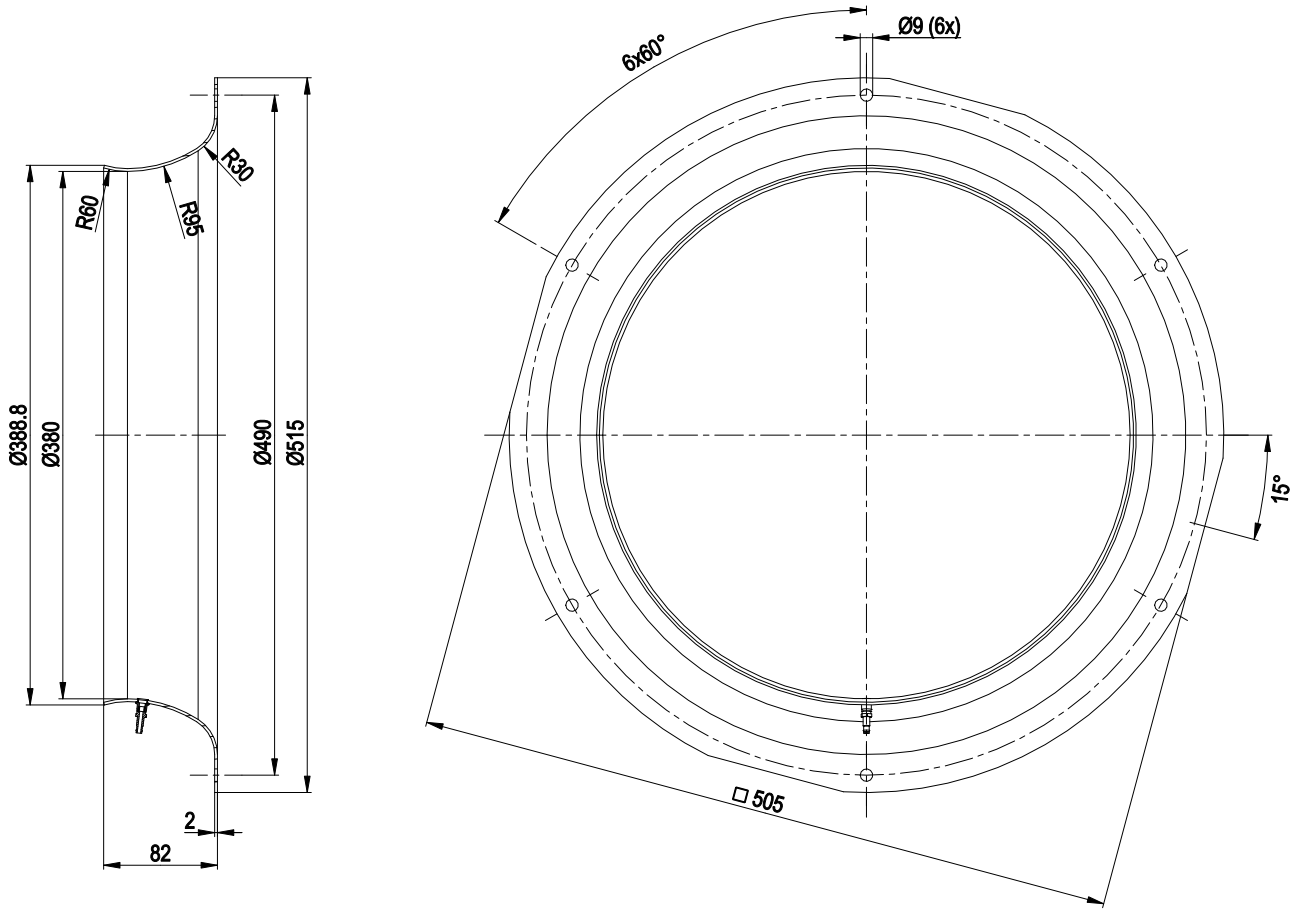

Inlet ring 64030-2-4013 with pressure tap not included in scope of delivery

## Connection diagram

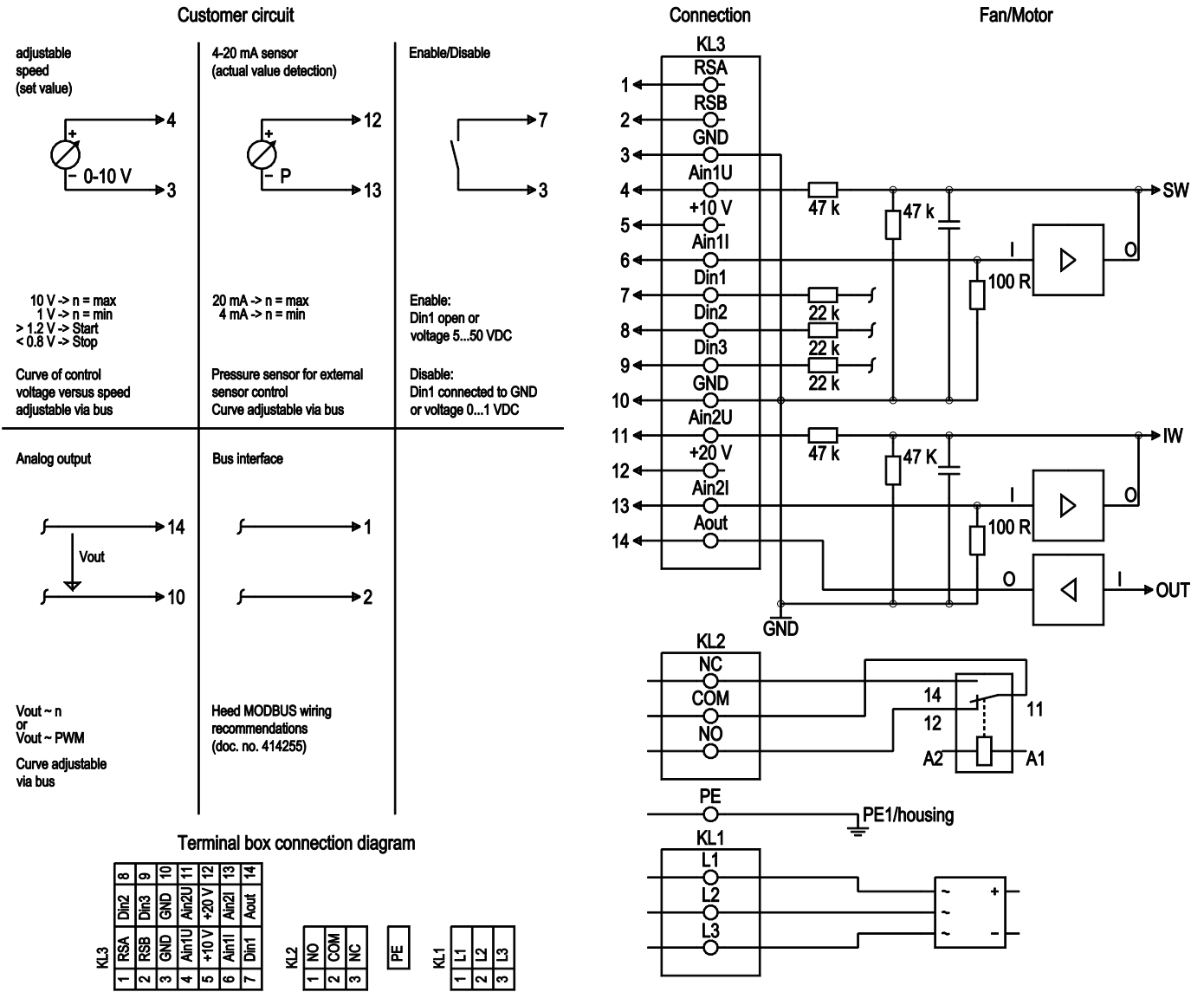

No.	Conn.	Designation	Function/assignment
KL 1	1	L1	Supply connection, power supply; for nominal voltage range see technical data
KL 1	2	L2	Supply connection, power supply; for nominal voltage range see technical data
KL 1	3	L3	Supply connection, power supply; for nominal voltage range see technical data
PE		PE	Ground connection, PE connection
KL 2	1	NO	Status relay, floating status contact, make for failure
KL2	2	COM	Status relay, floating status contact, changeover contact, common connection; contact rating 30 VAC/max. 2 A (AC1)/min. 10 mA
KL2	3	NC	Status relay, floating status contact, break for failure
KL 3	1	RSA	Bus connection RS485, RSA, MODBUS-RTU; SELV
KL 3	2	RSB	Bus connection RS485, RSB, MODBUS-RTU; SELV
KL 3	3 / 10	GND	Reference ground for control interface; SELV
KL 3	4	Ain1 U	Analog input 1, set value: 0-10 V, Ri = 100 kΩ, adjustable curve, only usable as alternative to input Ain1 I; SELV



No.	Conn.	Designation	Function/assignment
KL 3	5	+ 10 V	Fixed voltage output 10 VDC, +10 V +/-3%, max. 10 mA, short-circuit-proof, power supply for external devices (e.g. potentiometer); SELV
KL 3	6	Ain1 I	Analog input 1, set value: 4-20 mA, Ri = 100 Ω, adjustable curve, only usable as alternative to input Ain1 U; SELV
KL 3	7	Din1	Digital input 1: enable electronics, enable: pin open or applied voltage 5-50 VDC disable: bridge to GND or applied voltage < 1 VDC reset function: triggers software reset after a level change to < 1 VDC; SELV
KL 3	8	Din2	Digital input 2: Switching parameter sets 1/2, according to EEPROM setting, the valid or used parameter set can be selected via bus or via digital input DIN2. Parameter set 1: pin open or applied voltage 5-50 VDC Parameter set 2: bridge to GND or applied voltage < 1 VDC; SELV
KL 3	9	Din3	Digital input 3: according to EEPROM setting, the integrated controller's direction of action can be selected via bus or digital input Din3; normal: pin open or applied voltage 5-50 VDC inverse: bridge to GND or applied voltage < 1 VDC; SELV
KL 3	11	Ain2 U	Analog input 2, measured value: 0-10 V, Ri = 100 kΩ, adjustable curve, only usable as alternative to input Ain2 I; SELV
KL 3	12	+ 20 V	Fixed voltage output 20 VDC; +20 V +25/-10%, max. 50 mA, short-circuit-proof, power supply for external devices (e.g. sensors); SELV Alternatively: +24 VDC input for parameterization without line voltage
KL 3	13	Ain2 I	Analog input 2, measured value: 4-20 mA, Ri = 100 Ω, adjustable curve, only usable as alternative to input Ain2 U; SELV
KL 3	14	Aout	Analog output 0-10 VDC, max. 5 mA, output of current motor modulation level / motor speed adjustable curve; SELV

## Curves: Air performance 50 Hz

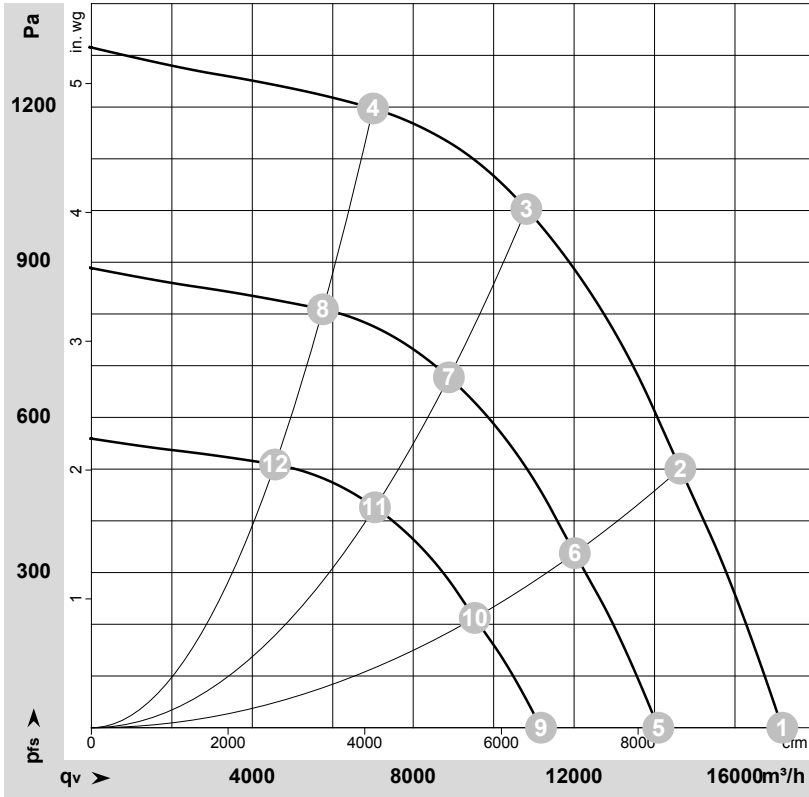

$\rho = 1.15 \text{ kg/m}^3 \pm 2 \%$

Measurement: LU-128639-1

Air performance measured according to ISO 5801 installation category A. For detailed information on the measurement setup, contact ebmpapst. Intake sound level: Sound power level according to ISO 13347 / sound pressure level measured at 1 m distance from fan axis. The values given are valid under the specified measuring conditions and may vary due to conditions of installation. For deviations from the standard configuration, the parameters have to be checked on the installed unit.

## Measured values

	Wired	U	f	n	P <sub>ed</sub>	I	LpA <sub>in</sub>	LwA <sub>in</sub>	LwA <sub>out</sub>	q <sub>v</sub>	p <sub>fs</sub>	q <sub>v</sub>	p <sub>fs</sub>
		V	Hz	min <sup>-1</sup>	W	A	dB(A)	dB(A)	dB(A)	m <sup>3</sup> /h	Pa	cfm	in. wg
1	3~	400	50	1750	3031	4.77	88	97	103	17175	0	10110	0.00
2	3~	400	50	1750	3969	6.16	84	91	96	14640	500	8615	2.01
3	3~	400	50	1750	4700	7.30	78	84	91	10815	1000	6365	4.01
4	3~	400	50	1750	4224	6.50	81	87	93	7000	1200	4120	4.82
5	3~	400	50	1450	1675	2.64	83	92	98	14095	0	8295	0.00
6	3~	400	50	1450	2193	3.40	79	86	91	12015	337	7075	1.35
7	3~	400	50	1450	2610	4.02	73	79	86	8885	678	5230	2.72
8	3~	400	50	1450	2346	3.61	76	82	88	5755	809	3385	3.25
9	3~	400	50	1150	836	1.32	77	86	92	11180	0	6580	0.00
10	3~	400	50	1150	1094	1.70	73	80	85	9530	212	5610	0.85
11	3~	400	50	1150	1302	2.00	67	74	80	7050	426	4150	1.71
12	3~	400	50	1150	1171	1.80	70	76	83	4565	509	2685	2.04

Wired = Wiring · U = Voltage · f = Frequency · n = Speed (rpm) · P<sub>ed</sub> = Power consumption · I = Current draw · LpA<sub>in</sub> = Sound pressure level intake side · LwA<sub>in</sub> = Sound power level intake side · LwA<sub>out</sub> = Sound power level outlet side · q<sub>v</sub> = Air flow · p<sub>fs</sub> = Pressure increase

