

R3G560-AH29-19

EC centrifugal fan

backward-curved, single-intake



R3G560-AH29-19 ebmpapst Datasheet

sales@fansco.com

www.fansco.com

Limited partnership · Headquarters Muldingen

Amtsgericht (court of registration) Stuttgart · HRA 590344

General partner Elektrobau Muldingen GmbH · Headquarters Muldingen

Amtsgericht (court of registration) Stuttgart · HRB 590142

Nominal data

Type	R3G560-AH29-19	
Motor	M3G150-IF	
Phase		3~
Nominal voltage	VAC	200
Nominal voltage range	VAC	200 .. 240
Frequency	Hz	50/60
Method of obtaining data		ml
Speed (rpm)	min ⁻¹	1520
Power consumption	W	3000
Current draw	A	9.8
Min. ambient temperature	°C	-25
Max. ambient temperature	°C	45

ml = Max. load · me = Max. efficiency · fa = Free air · cs = Customer specification · ce = Customer equipment
Subject to change



Technical description

Weight	28.5 kg
Fan size	560 mm
Rotor surface	Painted black
Electronics housing material	Die-cast aluminum
Impeller material	Sheet aluminum
Number of blades	9
Direction of rotation	Clockwise, viewed toward rotor
Degree of protection	IP55
Insulation class	"F"
Moisture (F) / Environmental (H) protection class	F4-1
Max. permitted ambient temp. for motor (transport/storage)	+80 °C
Min. permitted ambient temp. for motor (transport/storage)	-40 °C
Installation position	Shaft horizontal or rotor on bottom; rotor on top on request
Condensation drainage holes	On rotor side
Mode	S1
Motor bearing	Ball bearing
Technical features	<ul style="list-style-type: none"> - Output 10 VDC, max. 10 mA - Output 20 VDC, max. 50 mA - Output for slave 0-10 V - Operation and alarm display - Input for sensor 0-10 V or 4-20 mA - External 24 V input (parameter setting) - External release input - Alarm relay - Integrated PID controller - Motor current limitation - PFC, passive - RS-485 MODBUS-RTU - Soft start - Control input 0-10 VDC / PWM - Control interface with SELV potential safely disconnected from the mains - Thermal overload protection for electronics/motor - Line undervoltage / phase failure detection
EMC immunity to interference	According to EN 61000-6-2 (industrial environment)
EMC interference emission	According to EN 61000-6-4 (industrial environment)
Touch current according to IEC 60990 (measuring circuit Fig. 4, TN system)	<= 3.5 mA
Electrical hookup	Via terminal box
Motor protection	Reverse polarity and locked-rotor protection
Protection class	I (with customer connection of protective earth)
Conformity with standards	EN 61800-5-1; CE
Approval	C22.2 No.77 + CAN/CSA-E60730-1; UL 1004-7 + 60730

Product drawing

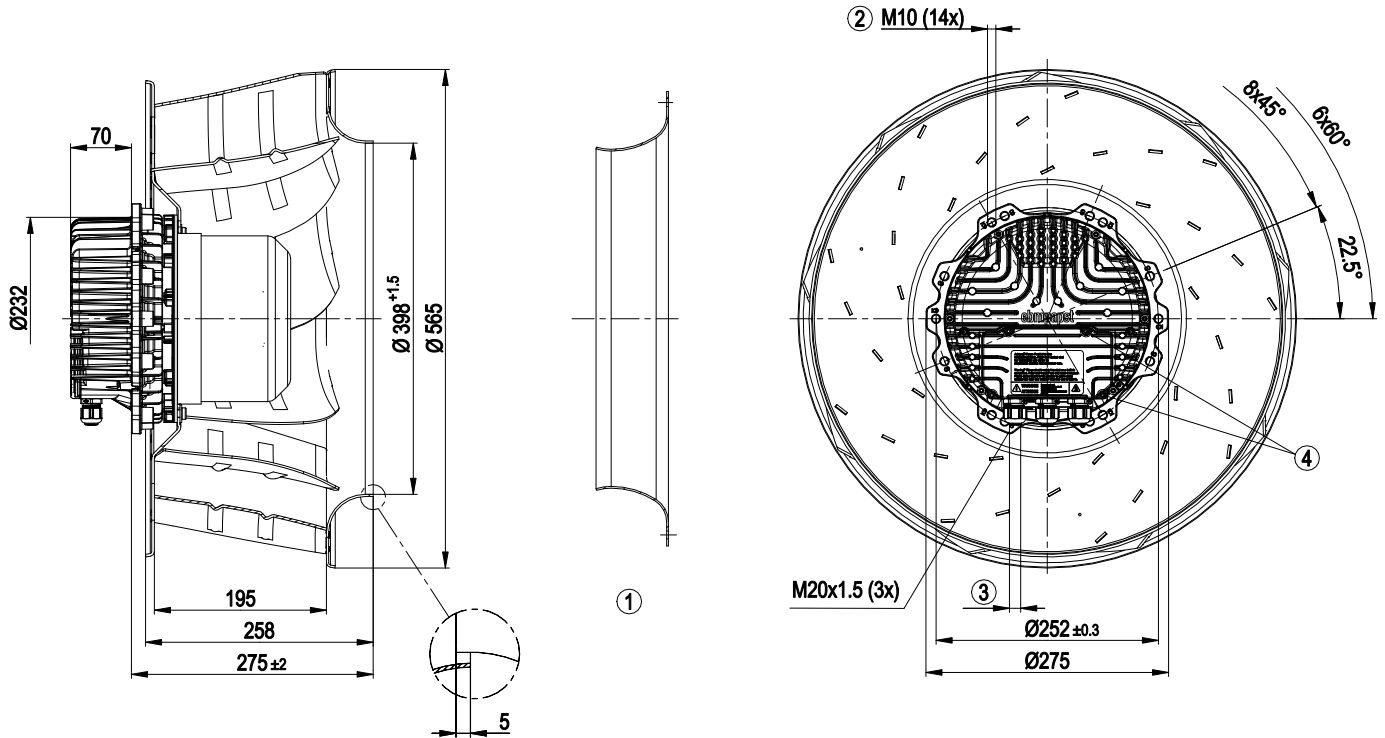

1	Accessory part: inlet ring 63071-2-4013 not included in scope of delivery
2	Max. clearance for screw 25 mm
3	Cable diameter min. 4 mm, max. 10 mm, tightening torque 4 ± 0.6 Nm
4	Tightening torque 3.5 ± 0.5 Nm



Accessory part

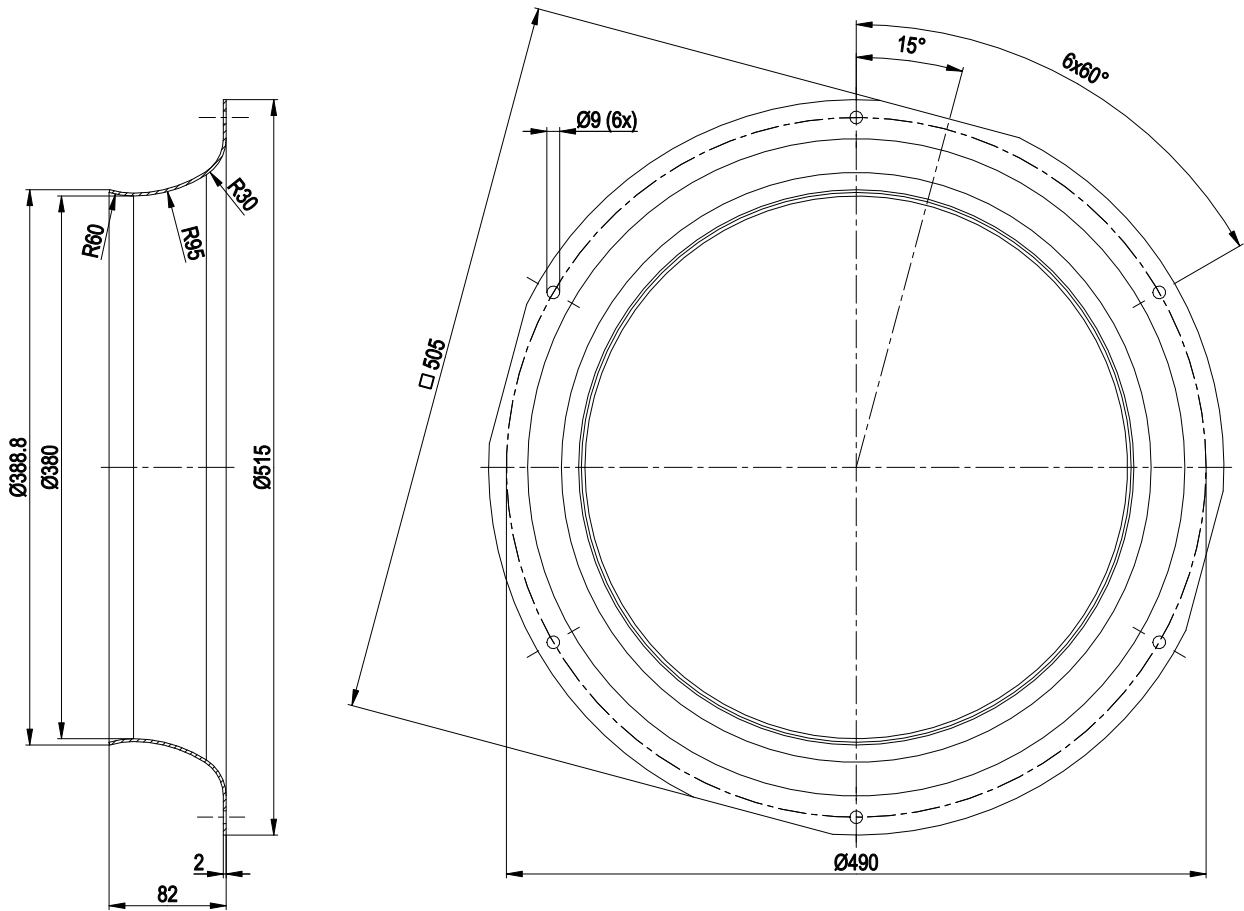

- inlet ring 63071-2-4013 not included in scope of delivery



EC centrifugal fan

backward-curved, single-intake

Connection diagram



No.	Conn.	Designation	Function/assignment
KL 1	1	L1	Supply connection, power supply 3-phase 200-240 VAC, 50/60 Hz
KL 1	2	L2	Supply connection, power supply 3-phase 200-240 VAC, 50/60 Hz
KL 1	3	L3	Supply connection, power supply 3-phase 200-240 VAC, 50/60 Hz
PE		PE	Ground connection, PE connection
KL 2	1	NO	Status relay, floating status contact, make for failure
KL2	2	COM	Status relay, floating status contact; changeover contact; common connection; contact rating 250 VAC / max. 2 A (AC1) / min. 10 mA
KL2	3	NC	Status relay, floating status contact, break for failure
KL 3	1	RSA	Bus connection RS485, RSA, MODBUS-RTU; SELV
KL 3	2	RSB	Bus connection RS485, RSB, MODBUS-RTU; SELV
KL 3	3 / 10	GND	Reference ground for control interface; SELV
KL 3	4	Ain1 U	Analog input 1, set value: 0-10 V, Ri = 100 kΩ, adjustable curve, only usable as alternative to input Ain1I; SELV
KL 3	5	+ 10 V	Fixed voltage output 10 VDC, +10 V ±3%, max. 10 mA, short-circuit-proof power supply for external devices (e.g. pot); SELV
KL 3	6	Ain1 I	Analog input 1, set value: 4-20 mA, Ri = 100 Ω, adjustable curve, only usable as alternative to input Ain1U; SELV
KL 3	7	Din1	Digital input 1: enable electronics, enable: pin open or applied voltage 5-50 VDC disable: bridge to GND or applied voltage < 1 VDC reset function: triggers software reset after a level change to < 1 VDC; SELV
KL 3	8	Din2	Digital input 2: Switching parameter sets 1/2, according to EEPROM setting, the valid or used parameter set can be selected via bus or via digital input DIN2. Parameter set 1: pin open or applied voltage 5-50 VDC Parameter set 2: bridge to GND or applied voltage < 1 VDC; SELV
KL 3	9	Din3	Digital input 3: according to EEPROM setting, the integrated controller's direction of action can be selected as normal/inverse via bus or digital input normal: pin open or applied voltage 5-50 VDC inverse: bridge to GND or applied voltage < 1 VDC; SELV
KL 3	11	Ain2 U	Analog input 2, measured value: 0-10 V, Ri = 100 kΩ, adjustable curve, only usable as alternative to input Ain2I; SELV
KL 3	12	+ 20 V	Fixed voltage output 20 VDC, +20 V ±5/-10%, max. 50 mA, short-circuit-proof power supply for external devices (e.g. sensors); SELV



EC centrifugal fan

backward-curved, single-intake

No.	Conn.	Designation	Function/assignment
KL 3	13	Ain2 I	Analog input 2, measured value: 4-20 mA, Ri = 100 Ω, adjustable curve, only usable as alternative to input Ain2U; SELV
KL 3	14	Aout	Analog output 0-10 VDC, max. 5 mA, output of current motor modulation level / motor speed adjustable curve; SELV



Curves: Air performance 50 Hz

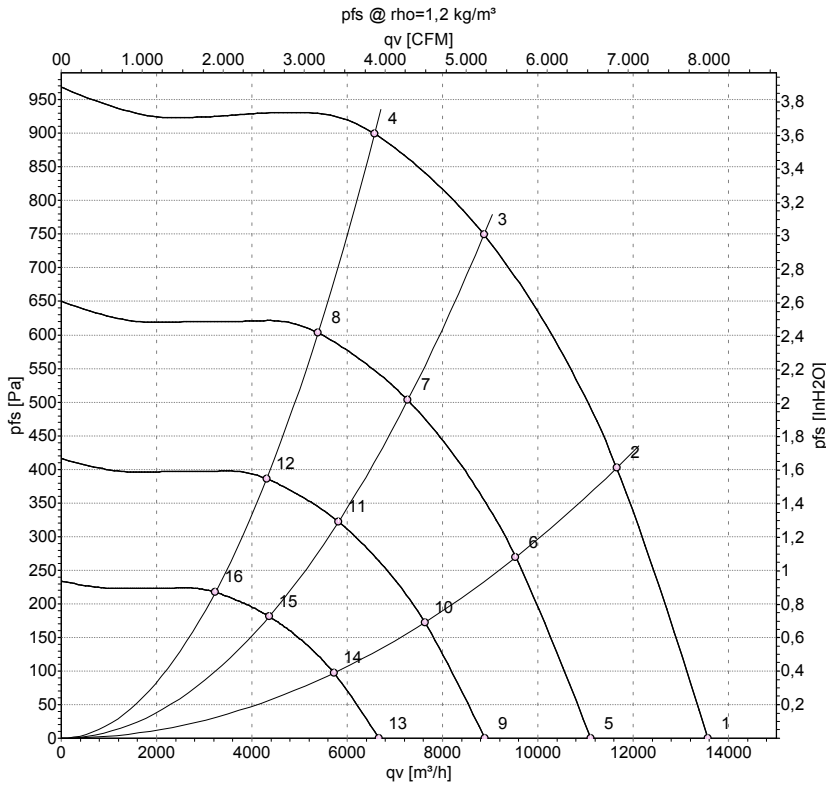

Measurement: LU-160260-1

Air performance measured according to ISO 5801 installation category A. For detailed information on the measurement setup, contact ebmpapst. Intake sound level: Sound power level according to ISO 13347 / sound pressure level measured at 1 m distance from fan axis. The values given are valid under the specified measuring conditions and may vary due to conditions of installation. For deviations from the standard configuration, the parameters have to be checked on the installed unit.

Measured values

	Wired	U	f	n	P _{ed}	I	LpA _{in}	LwA _{in}	LwA _{out}	qv	p _{fs}	qv	p _{fs}
		V	Hz	min ⁻¹	W	A	dB(A)	dB(A)	dB(A)	m ³ /h	Pa	CFM	inH2O
1	Y	200	50	1520	2146	6.71	83	89	95	13565	0	7985	0.00
2	Y	200	50	1520	2926	9.00	78	85	92	11650	400	6855	1.61
3	Y	200	50	1520	3000	9.80	74	82	88	8865	750	5220	3.01
4	Y	200	50	1520	2987	9.15	75	82	88	6575	900	3870	3.61
5	Y	200	50	1250	1177	3.68	78	84	89	11105	0	6535	0.00
6	Y	200	50	1250	1603	4.93	73	80	86	9530	274	5610	1.10
7	Y	200	50	1250	1758	5.45	69	77	83	7265	506	4275	2.03
8	Y	200	50	1250	1642	5.03	70	77	83	5385	604	3170	2.42
9	Y	200	50	1000	603	1.88	72	78	84	8885	0	5230	0.00
10	Y	200	50	1000	820	2.52	67	74	81	7625	175	4490	0.70
11	Y	200	50	1000	900	2.79	63	71	77	5815	324	3420	1.30
12	Y	200	50	1000	841	2.57	64	72	77	4310	386	2535	1.55
13	Y	200	50	750	254	0.79	65	71	77	6665	0	3920	0.00
14	Y	200	50	750	346	1.06	60	67	74	5720	98	3365	0.39
15	Y	200	50	750	380	1.18	56	64	70	4360	182	2565	0.73
16	Y	200	50	750	355	1.09	57	64	70	3230	217	1900	0.87

Wired = Wiring · U = Power supply · f = Frequency · n = Speed (rpm) · P_{ed} = Power consumption · I = Current draw · LpA_{in} = Sound pressure level intake side · LwA_{in} = Sound power level intake side
 LwA_{out} = Sound power level outlet side · qv = Air flow · p_{fs} = Pressure increase

