

R3G560-AH02-10

# EC centrifugal fan

backward-curved, single-intake



R3G560-AH02-10 ebmpapst Datasheet

sales@fansco.com

www.fansco.com

Limited partnership · Headquarters Muldingen  
Amtsgericht (court of registration) Stuttgart · HRA 590344

General partner Elektrobau Muldingen GmbH · Headquarters Muldingen  
Amtsgericht (court of registration) Stuttgart · HRB 590142



## Nominal data

|                          |                   |            |
|--------------------------|-------------------|------------|
| Type                     | R3G560-AH02-10    |            |
| Motor                    | M3G150-IF         |            |
| Phase                    |                   | 3~         |
| Nominal voltage          | VAC               | 400        |
| Nominal voltage range    | VAC               | 380 .. 480 |
| Frequency                | Hz                | 50/60      |
| Method of obtaining data |                   | ml         |
| Speed (rpm)              | min <sup>-1</sup> | 1510       |
| Power consumption        | W                 | 3100       |
| Current draw             | A                 | 4.9        |
| Min. ambient temperature | °C                | -25        |
| Max. ambient temperature | °C                | 60         |

ml = Max. load · me = Max. efficiency · fa = Free air · cs = Customer specification · ce = Customer equipment  
Subject to change

## Data according to ErP Directive

|                                   |   | Actual | Req. 2015 |                               |                   |      |
|-----------------------------------|---|--------|-----------|-------------------------------|-------------------|------|
| 01 Overall efficiency $\eta_{es}$ | % | 59.7   | 56.6      | 09 Power consumption $P_{ed}$ | kW                | 3.03 |
| 02 Measurement category           |   | A      |           | 09 Air flow $q_v$             | m <sup>3</sup> /h | 8745 |
| 03 Efficiency category            |   | Static |           | 09 Pressure increase $p_{fs}$ | Pa                | 709  |
| 04 Efficiency grade N             |   | 65.1   | 62        | 10 Speed (rpm) $n$            | min <sup>-1</sup> | 1505 |
| 05 Variable speed drive           |   | Yes    |           | 11 Specific ratio*            |                   | 1.01 |

Data obtained at optimum efficiency level.  
The ErP data is determined using a motor-impeller combination in a standardized measurement setup.

\* Specific ratio =  $1 + p_{fs} / 100\,000\text{ Pa}$

LU-109157



## Technical description

|  |  |
|--|--|
| Weight   | 27 kg  |
| Fan size   | 560 mm   |
| Rotor surface  | Painted black  |
| Electronics housing material   | Die-cast aluminum  |
| Impeller material  | Sheet aluminum   |
| Number of blades   | 9  |
| Direction of rotation  | Clockwise, viewed toward rotor   |
| Degree of protection   | IP55   |
| Insulation class   | "F"  |
| Moisture (F) / Environmental (H) protection class                          | F4-1   |
| Max. permitted ambient temp. for motor (transport/storage)                 | +80 °C   |
| Min. permitted ambient temp. for motor (transport/storage)                 | -40 °C   |
| Installation position  | Shaft horizontal or rotor on bottom; rotor on top on request   |
| Condensation drainage holes  | On rotor side  |
| Mode   | S1   |
| Motor bearing  | Ball bearing   |
| Technical features   | <ul style="list-style-type: none"> <li>- Output 10 VDC, max. 10 mA</li> <li>- Output 20 VDC, max. 50 mA</li> <li>- Output for slave 0-10 V</li> <li>- Input for sensor 0-10 V or 4-20 mA</li> <li>- Alarm relay</li> <li>- Integrated PID controller</li> <li>- Motor current limitation</li> <li>- PFC, passive</li> <li>- RS-485 ebmBUS</li> <li>- Soft start</li> <li>- Control input 0-10 VDC / PWM</li> <li>- Control interface with SELV potential safely disconnected from the mains</li> <li>- Thermal overload protection for electronics/motor</li> <li>- Line undervoltage / phase failure detection</li> </ul> |
| EMC immunity to interference   | According to EN 61000-6-2 (industrial environment)   |
| EMC interference emission  | According to EN 61000-6-3 (household environment)  |
| Touch current according to IEC 60990 (measuring circuit Fig. 4, TN system) | <= 3.5 mA  |
| Electrical hookup  | Via terminal box   |
| Motor protection   | Reverse polarity and locked-rotor protection   |
| Protection class   | I (with customer connection of protective earth)   |
| Conformity with standards  | EN 61800-5-1; CE   |
| Approval   | CSA C22.2 No. 100; UL 2111   |

Product drawing

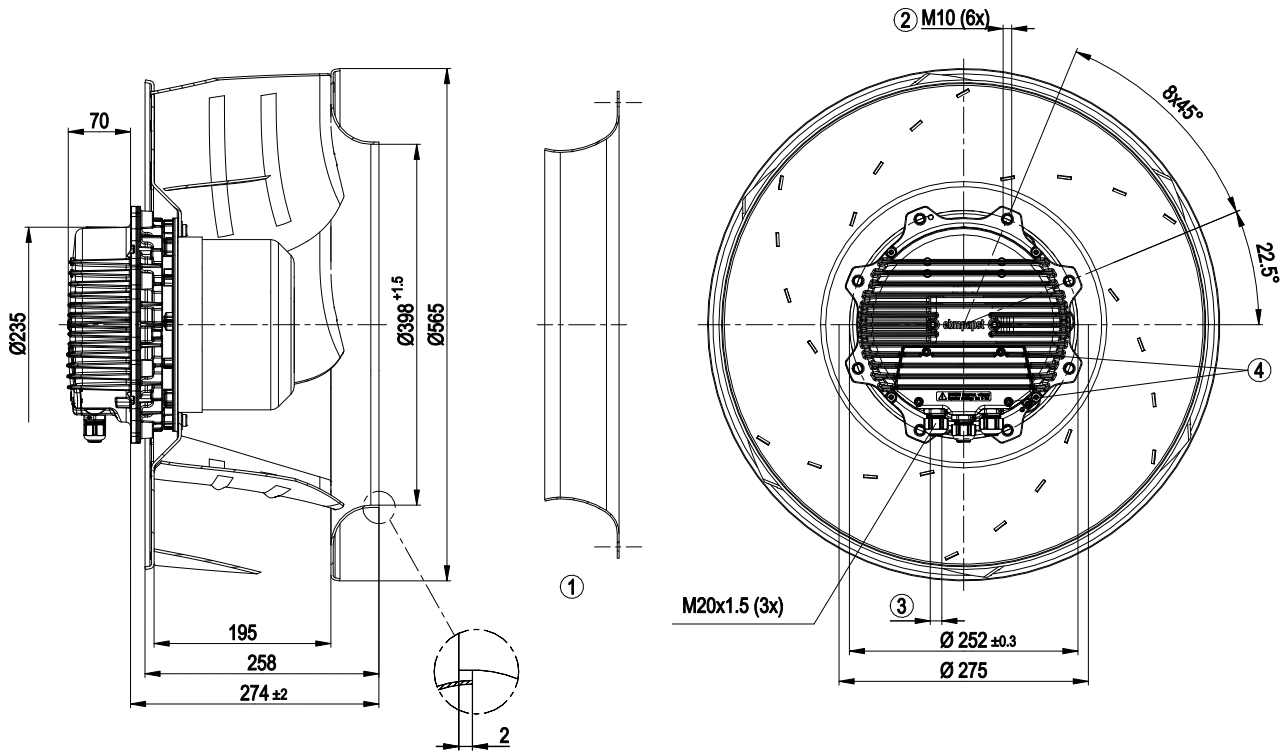

|   |   |
|---|---|
| 1 | Accessory part: inlet ring 63071-2-4013, not included in scope of delivery. |
| 2 | Max. clearance for screw 25 mm  |
| 3 | Cable diameter min. 4 mm, max. 10 mm, tightening torque 4 ± 0.6 Nm          |
| 4 | Tightening torque 3.5 ± 0.5 Nm  |



## Accessory part

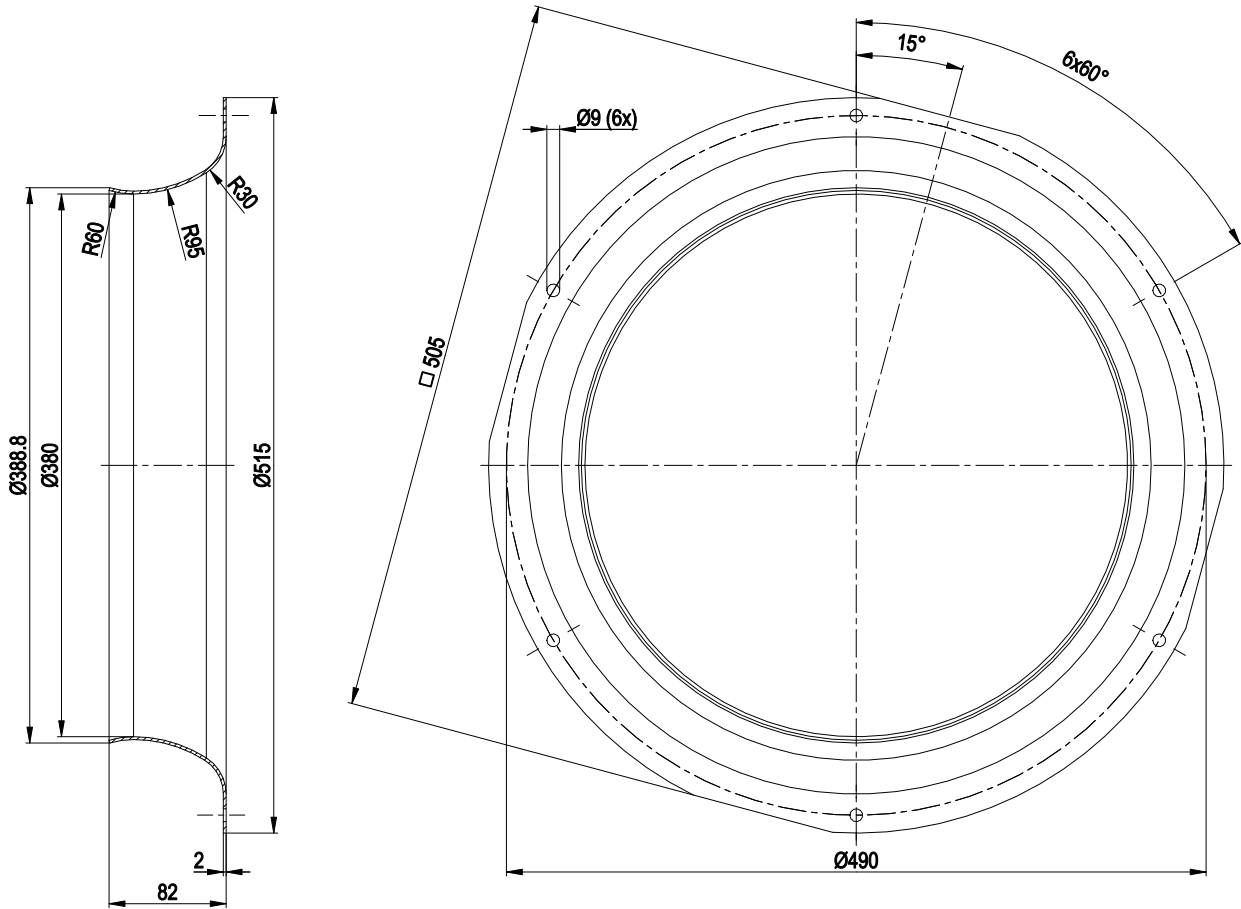

- inlet ring 63071-2-4013 not included in scope of delivery



## Connection diagram

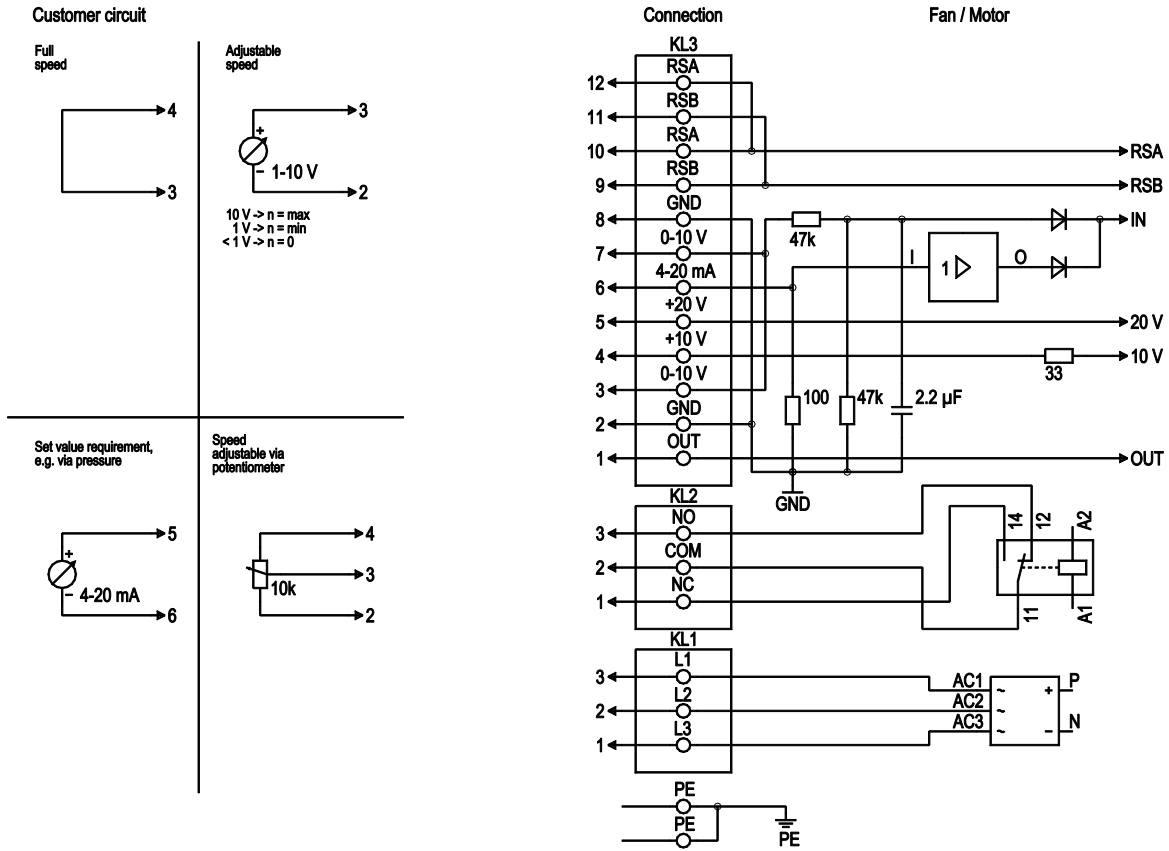

| No. | Conn.   | Designation | Function/assignment   |
|-----|---------|-------------|---|
| PE  |         | PE          | Protective earth terminal   |
| KL1 | 1, 2, 3 | L1, L2, L3  | Power supply 50/60 Hz   |
| KL2 | 1       | NC          | Floating status contact, break for failure  |
| KL2 | 2       | COM         | floating status contact, changeover contact, common connection (2 A, max. 250 VAC, min. 10 mA, AC1)   |
| KL2 | 3       | NO          | Floating status contact, make for failure   |
| KL3 | 1       | OUT         | Analog output, 0-10 VDC, max. 3 mA, SELV, output of current motor modulation level:<br>1 V corresponds to 10 % modulation level.<br>10 V corresponds to 100 % modulation level. |
| KL3 | 2, 8    | GND         | Reference ground for control interface, SELV  |
| KL3 | 3, 7    | 0-10 V      | Use control / current sensor value input 0-10 VDC, impedance 100 kΩ only as alternative to 4-20 mA input, SELV  |
| KL3 | 4       | +10 V       | Voltage output 10 VDC (±3 %), max. 10 mA, power supply for external devices (e.g. potentiometer), SELV  |
| KL3 | 5       | +20 V       | Voltage output 20 VDC (+25% / -10%), max. 50 mA, power supply for external devices (e.g. sensors); SELV   |
| KL3 | 6       | 4-20 mA     | Use control / current sensor value input 4-20 mA, impedance 100 Ω only as alternative to 0-10 V input, SELV   |
| KL3 | 9, 11   | RSB         | RS485 interface for ebmBUS, RSB, SELV   |
| KL3 | 10, 12  | RSA         | RS485 interface for ebmBUS, RSA, SELV   |



## Curves: Air performance 50 Hz

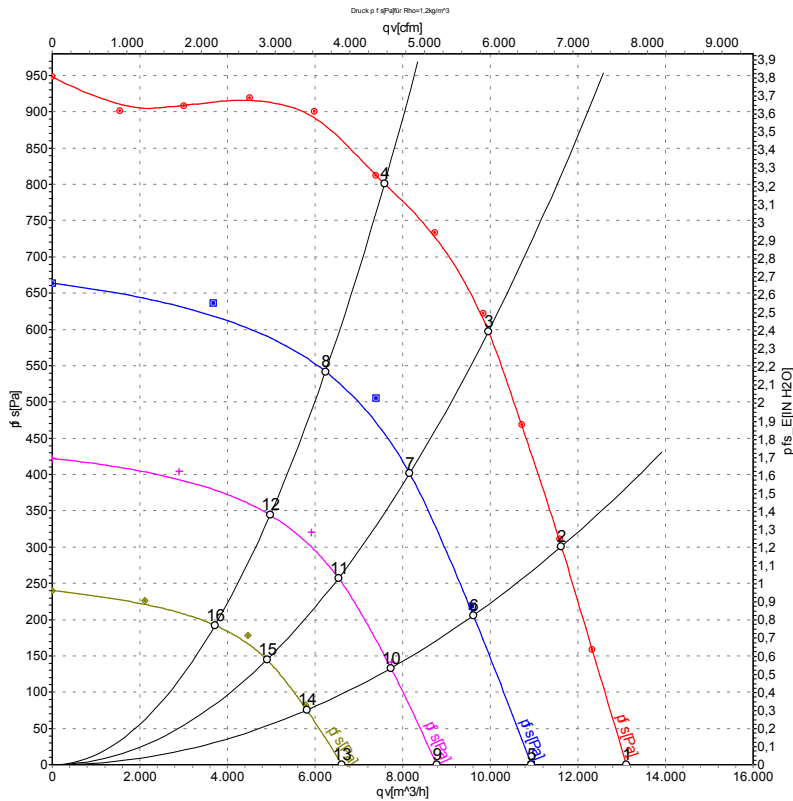

Measurement: LU-109157-1  
 Measurement: LU-111949-1  
 Measurement: LU-111950-1  
 Measurement: LU-111948-1

Air performance measured according to ISO 5801 installation category A. For detailed information on the measurement setup, contact ebmpapst. Intake sound level: Sound power level according to ISO 13347 / sound pressure level measured at 1 m distance from fan axis. The values given are valid under the specified measuring conditions and may vary due to conditions of installation. For deviations from the standard configuration, the parameters have to be checked on the installed unit.

## Measured values

|    | Wired | U   | f  | n                 | P <sub>ed</sub> | I    | LpA <sub>in</sub> | LwA <sub>in</sub> | LwA <sub>out</sub> | qv                | p <sub>fs</sub> | qv   | p <sub>fs</sub> |
|----|-------|-----|----|-------------------|-----------------|------|-------------------|-------------------|--------------------|-------------------|-----------------|------|-----------------|
|    |       | V   | Hz | min <sup>-1</sup> | W               | A    | dB(A)             | dB(A)             | dB(A)              | m <sup>3</sup> /h | Pa              | CFM  | inH2O           |
| 1  | Y     | 400 | 50 | 1510              | 1965            | 2.99 | 80                | 86                | 94                 | 13110             | 0               | 7715 | 0.00            |
| 2  | Y     | 400 | 50 | 1510              | 2553            | 3.88 | 78                | 84                | 92                 | 11620             | 300             | 6840 | 1.20            |
| 3  | Y     | 400 | 50 | 1510              | 3100            | 4.90 | 76                | 83                | 90                 | 9955              | 600             | 5860 | 2.41            |
| 4  | Y     | 400 | 50 | 1510              | 2981            | 4.53 | 75                | 82                | 89                 | 7585              | 800             | 4465 | 3.21            |
| 5  | Y     | 400 | 50 | 1250              | 1082            | 1.65 | 74                | 81                | 88                 | 10930             | 0               | 6435 | 0.00            |
| 6  | Y     | 400 | 50 | 1250              | 1392            | 2.12 | 72                | 79                | 86                 | 9615              | 216             | 5660 | 0.87            |
| 7  | Y     | 400 | 50 | 1250              | 1579            | 2.40 | 71                | 78                | 84                 | 8160              | 405             | 4805 | 1.63            |
| 8  | Y     | 400 | 50 | 1250              | 1557            | 2.37 | 71                | 78                | 84                 | 6240              | 546             | 3670 | 2.19            |
| 9  | Y     | 400 | 50 | 1000              | 583             | 0.95 | 67                | 74                | 81                 | 8775              | 0               | 5165 | 0.00            |
| 10 | Y     | 400 | 50 | 1000              | 734             | 1.16 | 66                | 73                | 79                 | 7735              | 142             | 4550 | 0.57            |
| 11 | Y     | 400 | 50 | 1000              | 826             | 1.30 | 65                | 72                | 78                 | 6535              | 260             | 3845 | 1.04            |
| 12 | Y     | 400 | 50 | 1000              | 811             | 1.27 | 65                | 72                | 78                 | 4970              | 346             | 2925 | 1.39            |
| 13 | Y     | 400 | 50 | 750               | 272             | 0.54 | 60                | 67                | 73                 | 6615              | 0               | 3895 | 0.00            |
| 14 | Y     | 400 | 50 | 750               | 330             | 0.63 | 60                | 67                | 73                 | 5810              | 80              | 3420 | 0.32            |
| 15 | Y     | 400 | 50 | 750               | 368             | 0.69 | 59                | 66                | 72                 | 4900              | 146             | 2885 | 0.59            |
| 16 | Y     | 400 | 50 | 750               | 357             | 0.67 | 58                | 66                | 72                 | 3715              | 193             | 2185 | 0.77            |

Wired = Wiring · U = Power supply · f = Frequency · n = Speed (rpm) · P<sub>ed</sub> = Power consumption · I = Current draw · LpA<sub>in</sub> = Sound pressure level intake side · LwA<sub>in</sub> = Sound power level intake side  
 LwA<sub>out</sub> = Sound power level outlet side · qv = Air flow · p<sub>fs</sub> = Pressure increase

