



R3G560-AH02-03 ebmpapst Datasheet FansCo

sales@fansco.com

www.fansco.com

### Nominal data

Type	R3G560-AH02-03	
Motor	M3G150-IF	
Phase		3~
Nominal voltage	VAC	400
Nominal voltage range	VAC	380 .. 480
Frequency	Hz	50/60
Method of obtaining data		ml
Speed (rpm)	min <sup>-1</sup>	1510
Power consumption	W	3100
Current draw	A	4.9
Max. ambient temperature	°C	60

ml = Max. load · me = Max. efficiency · fa = Free air · cs = Customer specification · ce = Customer equipment  
Subject to change

### Data according to Commission Regulation (EU) 327/2011

		Actual	Req. 2015			
01 Overall efficiency $\eta_{es}$	%	59.7	56.6	09 Power consumption $P_{ed}$	kW	3.03
02 Measurement category		A		09 Air flow $q_v$	m <sup>3</sup> /h	8745
03 Efficiency category		Static		09 Pressure increase $p_{fs}$	Pa	709
04 Efficiency grade N		65.1	62	10 Speed (rpm) n	min <sup>-1</sup>	1505
05 Variable speed drive		Yes		11 Specific ratio*		1.01

Data obtained at optimum efficiency level.

The ErP data is determined using a motor-impeller combination in a standardized measurement setup.

\* Specific ratio =  $1 + p_g / 100\,000\text{ Pa}$

LU-109157



## Technical description

<b>Weight</b>	28 kg
<b>Size</b>	560 mm
<b>Motor size</b>	150
<b>Rotor surface</b>	Painted black
<b>Electronics housing material</b>	Die-cast aluminum
<b>Impeller material</b>	Sheet aluminum
<b>Number of blades</b>	9
<b>Direction of rotation</b>	Clockwise, viewed toward rotor
<b>Degree of protection</b>	IP55
<b>Insulation class</b>	"F"
<b>Moisture (F) / Environmental (H) protection class</b>	F4-1
<b>Max. permitted ambient temp. for motor (transport/storage)</b>	+80 °C
<b>Min. permitted ambient temp. for motor (transport/storage)</b>	-40 °C
<b>Installation position</b>	Shaft horizontal or rotor on bottom; rotor on top on request
<b>Condensation drainage holes</b>	On rotor side
<b>Mode</b>	S1
<b>Motor mounting</b>	Ball bearing
<b>Technical features</b>	<ul style="list-style-type: none"> <li>- Output 10 VDC max. 10 mA</li> <li>- Output 20 VDC max. 50 mA</li> <li>- Output for slave 0-10 V</li> <li>- Input for sensor 0-10 V or 4-20 mA</li> <li>- Alarm relay</li> <li>- Integrated PID controller</li> <li>- Motor current limitation</li> <li>- PFC, passive</li> <li>- RS-485 ebmBUS</li> <li>- Soft start</li> <li>- Control input 0-10 VDC / PWM</li> <li>- Control interface with SELV potential safely disconnected from supply</li> <li>- Thermal overload protection for electronics/motor</li> <li>- Undervoltage / phase failure detection</li> </ul>
<b>EMC immunity to interference</b>	According to EN 61000-6-2 (industrial environment)
<b>EMC interference emission</b>	According to EN 61000-6-3 (household environment)
<b>Touch current according to IEC 60990 (measuring circuit Fig. 4, TN system)</b>	<= 3.5 mA
<b>Electrical hookup</b>	Terminal box
<b>Motor protection</b>	Reverse polarity and locked-rotor protection
<b>Protection class</b>	I (with customer connection of protective earth)
<b>Conformity with standards</b>	EN 61800-5-1; CE
<b>Approval</b>	EAC; CSA C22.2 No. 77 + C22.2 No. 14; UL 1004-3 + UL 508C; VDE

# EC centrifugal fan

backward-curved, single-intake

## Product drawing

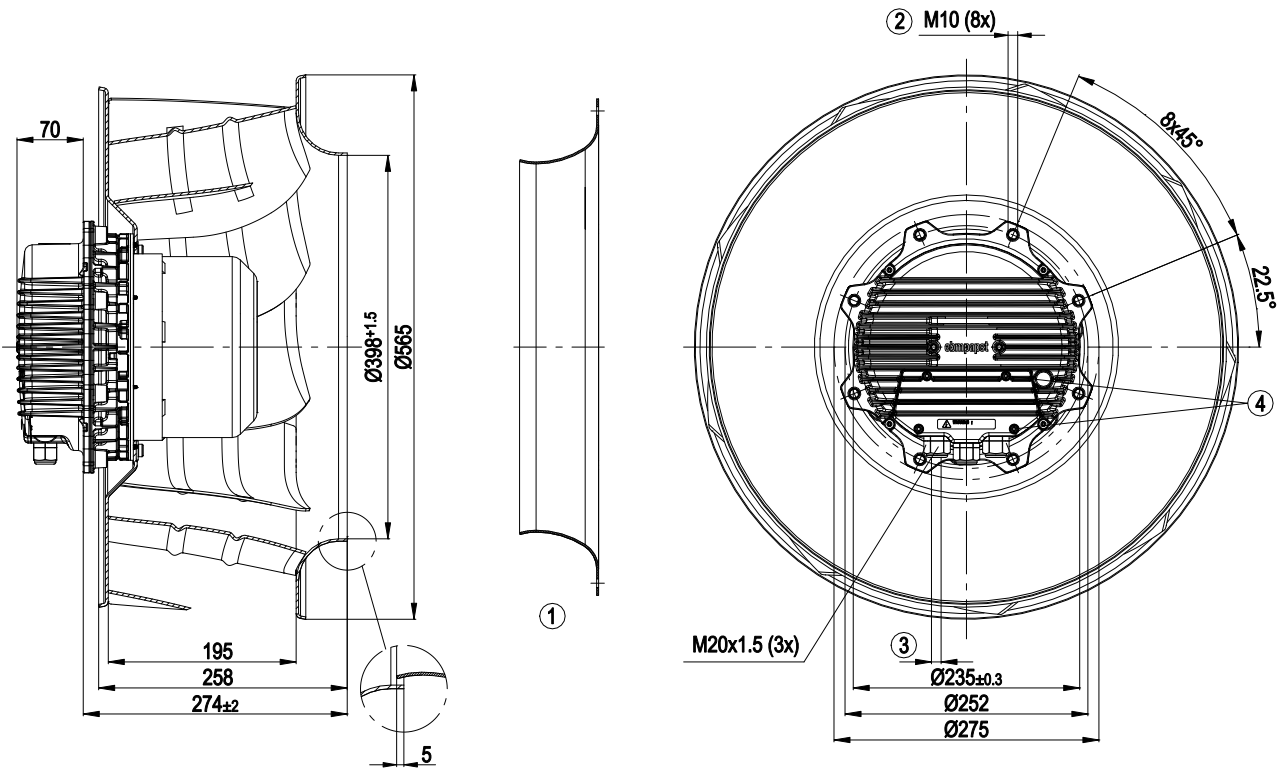

1	Accessory part: inlet ring 63071-2-4013 not included in scope of delivery
2	Max. clearance for screw 25 mm
3	Cable diameter min. 4 mm, max. 10 mm; tightening torque 4 ± 0.6 Nm
4	Tightening torque 3.5 ± 0.5 Nm



## Accessory part

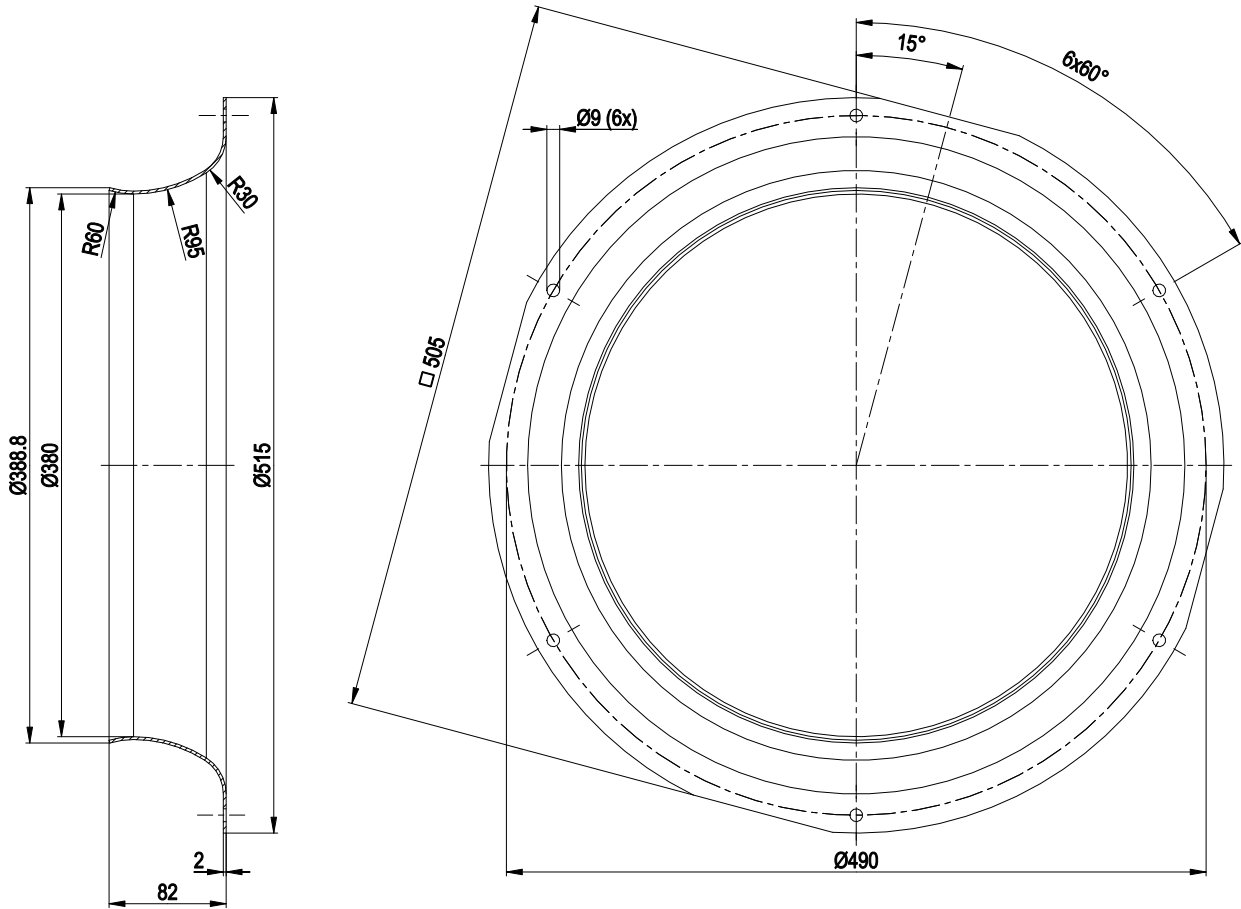

- inlet ring 63071-2-4013 not included in scope of delivery

## Connection diagram

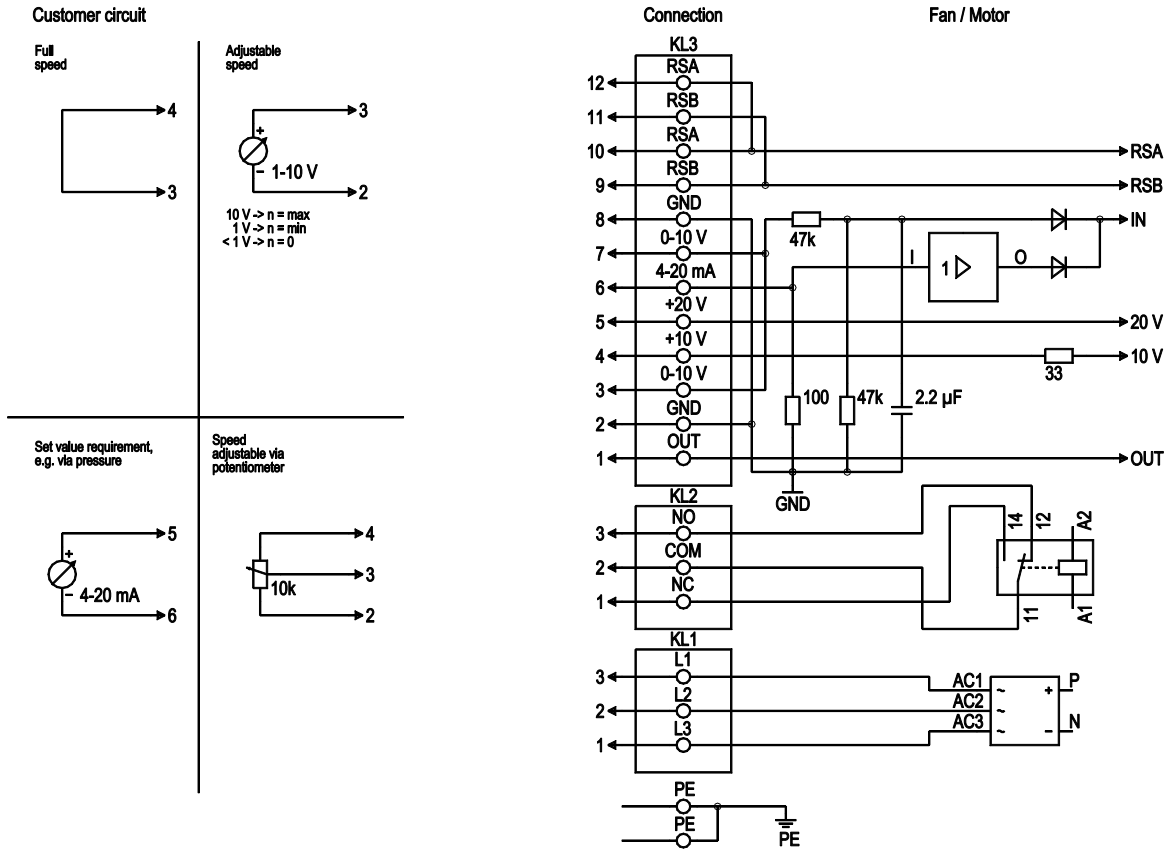

No.	Conn.	Designation	Function/assignment
PE		PE	Protective earth terminal
KL1	1, 2, 3	L1, L2, L3	Power supply 50/60 Hz
KL2	1	NC	Floating status contact, break for failure
KL2	2	COM	floating status contact, changeover contact, common connection (2 A, max. 250 VAC, min. 10 mA, AC1)
KL2	3	NO	Floating status contact, make for failure
KL3	1	OUT	Analog output, 0-10 VDC, max. 3 mA, SELV, output of current motor modulation level: 1 V corresponds to 10 % modulation level. 10 V corresponds to 100 % modulation level.
KL3	2, 8	GND	Reference ground for control interface, SELV
KL3	3, 7	0-10 V	Use control / current sensor value input 0-10 VDC, impedance 100 kΩ only as alternative to 4-20 mA input, SELV
KL3	4	+10 V	Voltage output 10 VDC (±3 %), max. 10 mA, power supply for external devices (e.g. potentiometer), SELV
KL3	5	+20 V	Voltage output 20 VDC (+25% / -10%), max. 50 mA, power supply for external devices (e.g. sensors); SELV
KL3	6	4-20 mA	Use control / current sensor value input 4-20 mA, impedance 100 Ω only as alternative to 0-10 V input, SELV
KL3	9, 11	RSB	RS485 interface for ebmBUS, RSB, SELV
KL3	10, 12	RSA	RS485 interface for ebmBUS, RSA, SELV



## Curves: Air performance 50 Hz

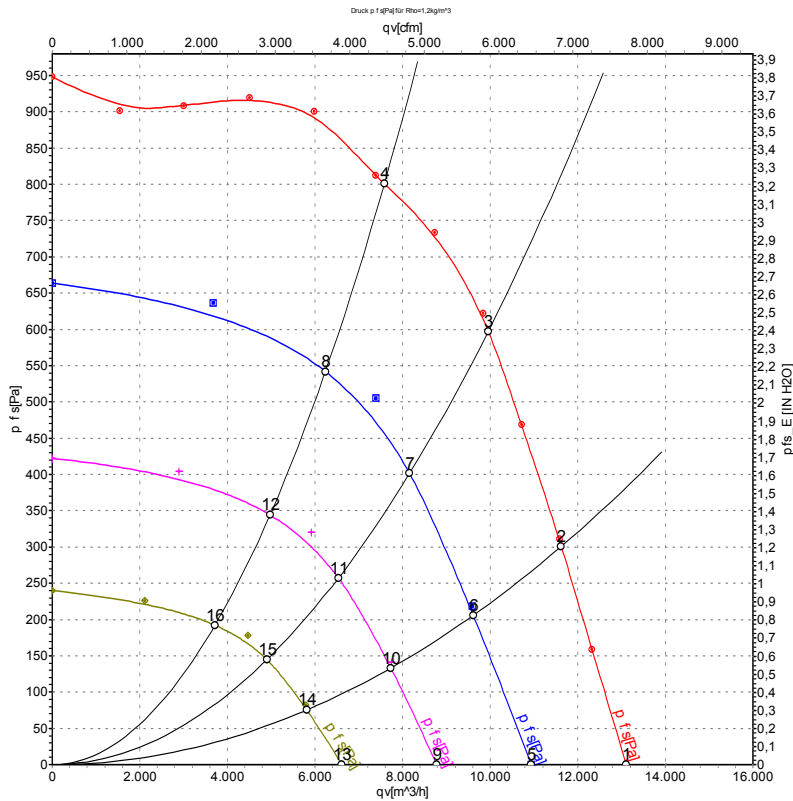

Measurement: LU-109157-1  
 Measurement: LU-111949-1  
 Measurement: LU-111950-1  
 Measurement: LU-111948-1

Air performance measured according to ISO 5801 installation category A. For detailed information on the measurement setup, contact ebmpapst. Intake sound level: Sound power level according to ISO 13347 / sound pressure level measured at 1 m distance from fan axis. The values given are valid under the specified measuring conditions and may vary due to conditions of installation. For deviations from the standard configuration, the parameters have to be checked on the installed unit.

## Measured values

	Wired	U	f	n	P <sub>ed</sub>	I	LpA <sub>in</sub>	LwA <sub>in</sub>	LwA <sub>out</sub>	q <sub>v</sub>	P <sub>fs</sub>	q <sub>v</sub>	P <sub>fs</sub>
		V	Hz	min <sup>-1</sup>	W	A	dB(A)	dB(A)	dB(A)	m <sup>3</sup> /h	Pa	cfm	in. wg
1	Y	400	50	1510	1965	2.99	80	86	94	13110	0	7715	0.00
2	Y	400	50	1510	2553	3.88	78	84	92	11620	300	6840	1.20
3	Y	400	50	1510	3100	4.90	76	83	90	9955	600	5860	2.41
4	Y	400	50	1510	2981	4.53	75	82	89	7585	800	4465	3.21
5	Y	400	50	1250	1082	1.65	74	81	88	10930	0	6435	0.00
6	Y	400	50	1250	1392	2.12	72	79	86	9615	216	5660	0.87
7	Y	400	50	1250	1579	2.40	71	78	84	8160	405	4805	1.63
8	Y	400	50	1250	1557	2.37	71	78	84	6240	546	3670	2.19
9	Y	400	50	1000	583	0.95	67	74	81	8775	0	5165	0.00
10	Y	400	50	1000	734	1.16	66	73	79	7735	142	4550	0.57
11	Y	400	50	1000	826	1.30	65	72	78	6535	260	3845	1.04
12	Y	400	50	1000	811	1.27	65	72	78	4970	346	2925	1.39
13	Y	400	50	750	272	0.54	60	67	73	6615	0	3895	0.00
14	Y	400	50	750	330	0.63	60	67	73	5810	80	3420	0.32
15	Y	400	50	750	368	0.69	59	66	72	4900	146	2885	0.59
16	Y	400	50	750	357	0.67	58	66	72	3715	193	2185	0.77

Wired = Wiring · U = Power supply · f = Frequency · n = Speed (rpm) · P<sub>ed</sub> = Power consumption · I = Current draw · LpA<sub>in</sub> = Sound pressure level intake side · LwA<sub>in</sub> = Sound power level intake side  
 LwA<sub>out</sub> = Sound power level outlet side · q<sub>v</sub> = Air flow · P<sub>fs</sub> = Pressure increase

