

R3G560-AE07-03

EC centrifugal fan

backward-curved, single-intake



R3G560-AE07-03 ebmpapst Datasheet

sales@fansco.com

www.fansco.com

Limited partnership · Headquarters Mulfingen
 Amtsgericht (court of registration) Stuttgart · HRA 590344

General partner Elektrobau Mulfingen GmbH · Headquarters Mulfingen
 Amtsgericht (court of registration) Stuttgart · HRB 590142



Nominal data

Type	R3G560-AE07-03	
Motor	M3G150-FF	
Phase		3~
Nominal voltage	VAC	400
Nominal voltage range	VAC	380 .. 480
Frequency	Hz	50/60
Method of obtaining data		ml
Status		prelim.
Speed (rpm)	min ⁻¹	1350
Power consumption	W	2050
Current draw	A	3.4
Min. ambient temperature	°C	-25
Max. ambient temperature	°C	60

ml = Max. load · me = Max. efficiency · fa = Free air · cs = Customer specification · ce = Customer equipment
 Subject to change

Data according to ErP Directive

		Actual	Req. 2015			
01 Overall efficiency η_{es}	%	62.4	54.7	09 Power consumption P_{ed}	kW	2.03
02 Measurement category		A		09 Air flow q_v	m ³ /h	7135
03 Efficiency category		Static		09 Pressure increase p_{fs}	Pa	600
04 Efficiency grade N		69.7	62	10 Speed (rpm) n	min ⁻¹	1365
05 Variable speed drive		Yes		11 Specific ratio*		1.01

Data obtained at optimum efficiency level.
 The ErP data is determined using a motor-impeller combination in a standardized measurement setup.

* Specific ratio = $1 + p_{fs} / 100\,000\text{ Pa}$

LU-66858



Technical description

Weight	23 kg
Fan size	560 mm
Rotor surface	Painted black
Electronics housing material	Die-cast aluminum
Impeller material	Sheet aluminum
Number of blades	6
Direction of rotation	Clockwise, viewed toward rotor
Degree of protection	IP55
Insulation class	"F"
Moisture (F) / Environmental (H) protection class	F4-1
Max. permitted ambient temp. for motor (transport/storage)	+80 °C
Min. permitted ambient temp. for motor (transport/storage)	-40 °C
Installation position	Shaft horizontal or rotor on top; rotor on bottom on request
Condensation drainage holes	On rotor side
Mode	S1
Motor bearing	Ball bearing
Technical features	<ul style="list-style-type: none"> - Output 10 VDC, max. 10 mA - Output 20 VDC, max. 50 mA - Output for slave 0-10 V - Input for sensor 0-10 V or 4-20 mA - Alarm relay - Integrated PID controller - Motor current limitation - PFC, passive - RS-485 ebmBUS - Soft start - Control input 0-10 VDC / PWM - Control interface with SELV potential safely disconnected from the mains - Thermal overload protection for electronics/motor - Line undervoltage / phase failure detection
EMC immunity to interference	According to EN 61000-6-2 (industrial environment)
EMC interference emission	According to EN 61000-6-3 (household environment)
Touch current according to IEC 60990 (measuring circuit Fig. 4, TN system)	<= 3.5 mA
Electrical hookup	Via terminal box
Motor protection	Reverse polarity and locked-rotor protection
Protection class	I (with customer connection of protective earth)
Conformity with standards	EN 61800-5-1; CE
Approval	CSA C22.2 No. 77; EAC; UL 2111; VDE

EC centrifugal fan

backward-curved, single-intake

Product drawing

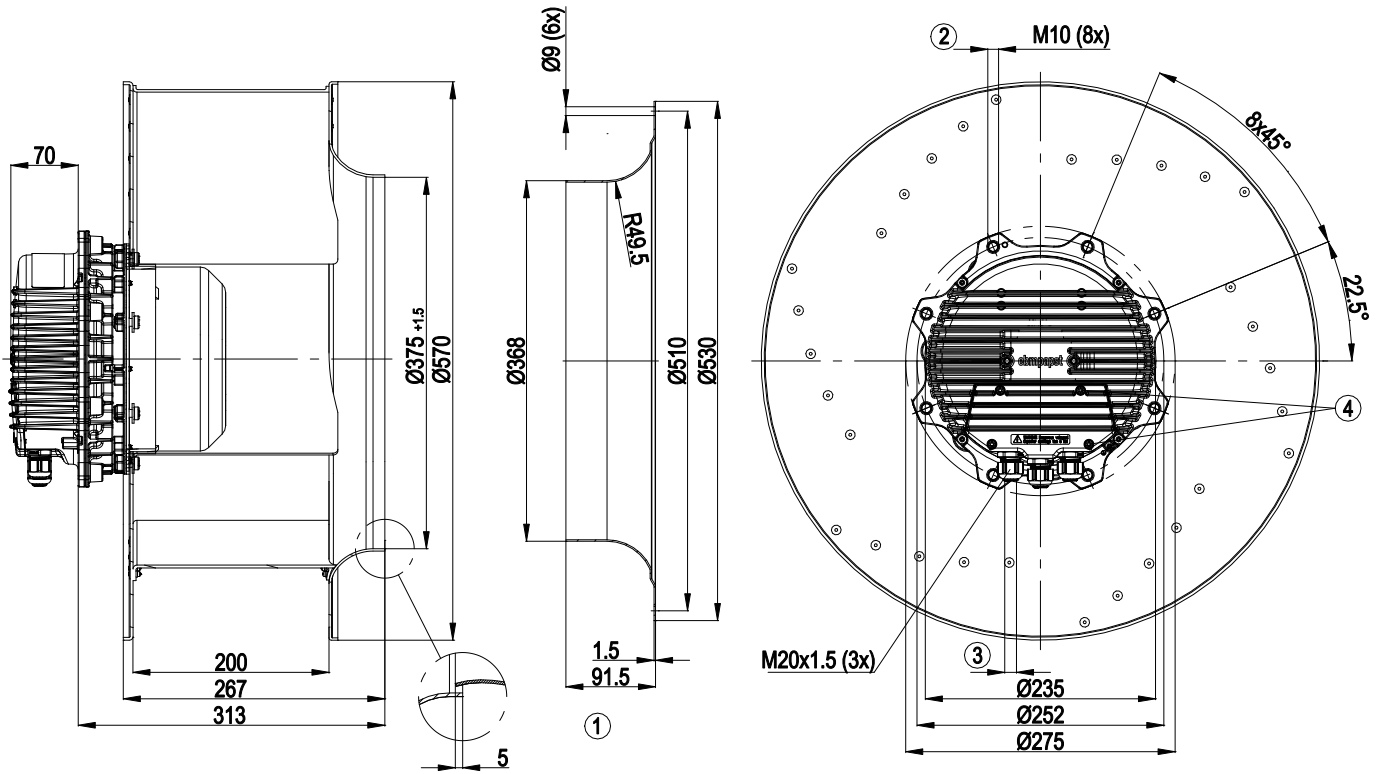

1	Accessory part: Inlet ring 45010-2-4013 not included in scope of delivery
2	Max. clearance for screw 25 mm
3	Cable diameter min. 4 mm, max. 10 mm, tightening torque 4 ± 0.6 Nm
4	Tightening torque 3.5 ± 0.5 Nm



Connection diagram

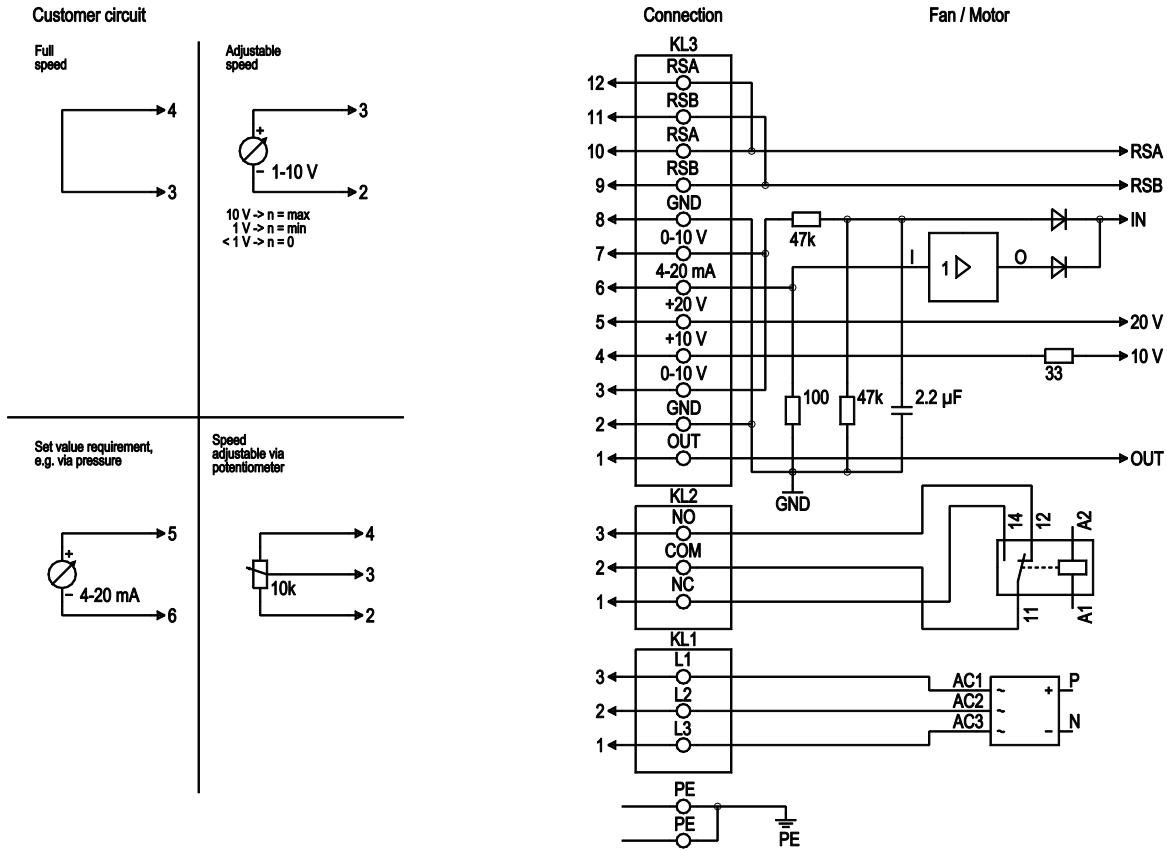

No.	Conn.	Designation	Function/assignment
PE		PE	Protective earth terminal
KL1	1, 2, 3	L1, L2, L3	Power supply 50/60 Hz
KL2	1	NC	Floating status contact, break for failure
KL2	2	COM	floating status contact, changeover contact, common connection (2 A, max. 250 VAC, min. 10 mA, AC1)
KL2	3	NO	Floating status contact, make for failure
KL3	1	OUT	Analog output, 0-10 VDC, max. 3 mA, SELV, output of current motor modulation level: 1 V corresponds to 10 % modulation level. 10 V corresponds to 100 % modulation level.
KL3	2, 8	GND	Reference ground for control interface, SELV
KL3	3, 7	0-10 V	Use control / current sensor value input 0-10 VDC, impedance 100 kΩ only as alternative to 4-20 mA input, SELV
KL3	4	+10 V	Voltage output 10 VDC (±3 %), max. 10 mA, power supply for external devices (e.g. potentiometer), SELV
KL3	5	+20 V	Voltage output 20 VDC (+25% / -10%), max. 50 mA, power supply for external devices (e.g. sensors); SELV
KL3	6	4-20 mA	Use control / current sensor value input 4-20 mA, impedance 100 Ω only as alternative to 0-10 V input, SELV
KL3	9, 11	RSB	RS485 interface for ebmBUS, RSB, SELV
KL3	10, 12	RSA	RS485 interface for ebmBUS, RSA, SELV



Curves: Air performance 50 Hz

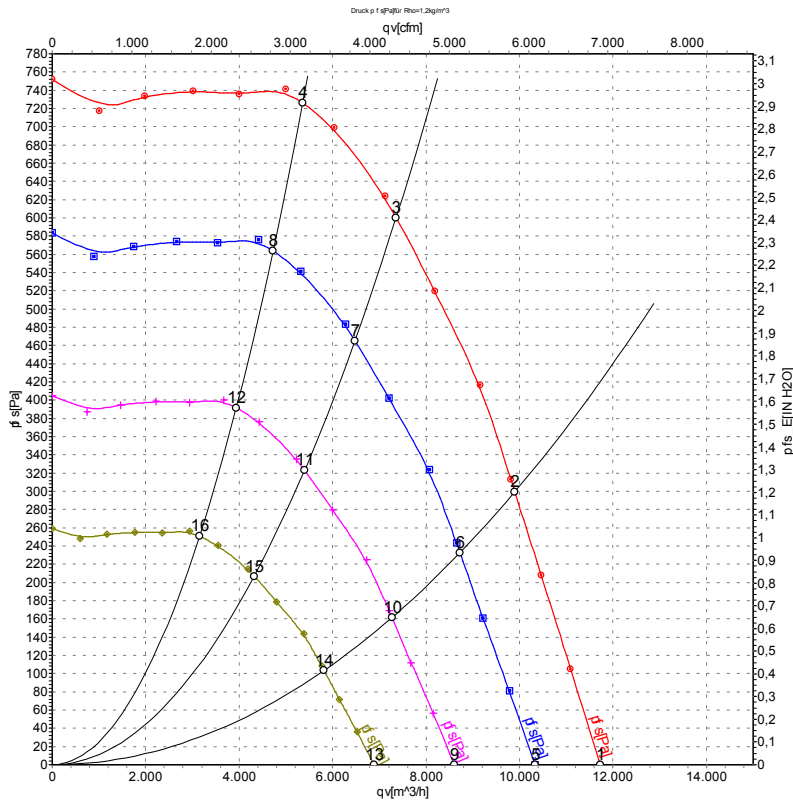

Measurement: LU-66858-1

Air performance measured according to ISO 5801 installation category A. For detailed information on the measurement setup, contact ebmpapst. Intake sound level: Sound power level according to ISO 13347 / sound pressure level measured at 1 m distance from fan axis. The values given are valid under the specified measuring conditions and may vary due to conditions of installation. For deviations from the standard configuration, the parameters have to be checked on the installed unit.

Measured values

	U	f	n	P _{ed}	I	qv	p _{is}	qv	p _{is}
	V	Hz	min ⁻¹	W	A	m ³ /h	Pa	CFM	inH ₂ O
1	400	50	1350	1374	2.41	11730	0	6905	0.00
2	400	50	1350	1761	3.78	9900	300	5825	1.20
3	400	50	1350	2050	3.95	7360	600	4330	2.41
4	400	50	1350	1870	4.00	5365	725	3155	2.91
5	400	50	1200	938	1.64	10330	0	6080	0.00
6	400	50	1200	1207	2.59	8725	233	5135	0.94
7	400	50	1200	1378	2.70	6480	466	3815	1.87
8	400	50	1200	1280	2.76	4725	564	2780	2.26
9	400	50	1000	543	0.95	8605	0	5065	0.00
10	400	50	1000	698	1.50	7270	162	4280	0.65
11	400	50	1000	798	1.56	5400	324	3175	1.30
12	400	50	1000	741	1.60	3940	392	2320	1.57
13	400	50	800	278	0.49	6885	0	4050	0.00
14	400	50	800	358	0.77	5815	104	3425	0.42
15	400	50	800	408	0.80	4320	207	2540	0.83
16	400	50	800	379	0.82	3150	251	1855	1.01

U = Power supply · f = Frequency · n = Speed (rpm) · P_{ed} = Power consumption · I = Current draw · qv = Air flow · p_{is} = Pressure increase

