

R3G560-8317081574  
8317081574

# EC centrifugal fan - RadiCal

backward-curved, single-intake

ebm-papst Ventilator (Shanghai) Co.,Ltd.

No.418, Hua Jing Road, Pilot Free Trade Zone, Pudong District

Shanghai, China, 200131

R3G560-8317081574 ebmpapst Datasheet

sales@fansco.com

www.fansco.com

## Nominal data

Type	R3G560-8317081574	
Motor	M3G150-FF	
Phase		3~
Nominal voltage	VAC	400
Nominal voltage range	VAC	380 .. 480
Frequency	Hz	50/60
Method of obtaining data		ml
Status		prelim.
Speed (rpm)	min <sup>-1</sup>	1900
Power consumption	W	3950
Current draw	A	6.0
Min. ambient temperature	°C	-40
Max. ambient temperature	°C	40

ml = Max. load · me = Max. efficiency · fa = Free air · cs = Customer specification · ce = Customer equipment  
Subject to change



## Technical description

<b>Weight</b>	20.9 kg
<b>Size</b>	560 mm
<b>Motor size</b>	150
<b>Rotor surface</b>	Painted black
<b>Electronics housing material</b>	Die-cast aluminum, painted gray
<b>Impeller material</b>	PP plastic
<b>Number of blades</b>	6
<b>Direction of rotation</b>	Clockwise, viewed toward rotor
<b>Degree of protection</b>	IP55
<b>Insulation class</b>	"F"
<b>Moisture (F) / Environmental (H) protection class</b>	H2+
<b>Ambient temperature note</b>	Occasional start-up at temperatures between -40°C and -25°C is permitted. For continuous operation at ambient temperatures below -25°C (such as refrigeration applications), use must be made of a fan design with special low-temperature bearings.
<b>Max. permitted ambient temp. for motor (transport/storage)</b>	+80 °C
<b>Min. permitted ambient temp. for motor (transport/storage)</b>	-40 °C
<b>Installation position</b>	Shaft horizontal or rotor on bottom; rotor on top on request
<b>Condensation drainage holes</b>	On rotor side
<b>Mode</b>	S1
<b>Motor bearing</b>	Ball bearing; (sealed)
<b>Technical features</b>	<ul style="list-style-type: none"> <li>- Operation and alarm display with LED</li> <li>- External 15-50 VDC input (parameterization)</li> <li>- Alarm relay</li> <li>- Integrated PI controller</li> <li>- Configurable inputs/outputs (I/O)</li> <li>- MODBUS V6.0</li> <li>- Motor current limitation</li> <li>- RFID - ISO 15693 compatible</li> <li>- RS-485 MODBUS-RTU</li> <li>- Soft start</li> <li>- Voltage output 3.3-24 VDC, Pmax = 800 mW</li> <li>- Control interface with SELV potential safely disconnected from the mains</li> <li>- Thermal overload protection for electronics/motor</li> <li>- Line undervoltage / phase failure detection</li> </ul>
<b>EMC immunity to interference</b>	According to EN 61000-6-2 (industrial environment)
<b>EMC interference emission</b>	According to EN 61000-6-3 (household environment), except EN 61000-3-2 for professionally used equipment with a total rated power greater than 1 kW
<b>Touch current according to IEC 60990 (measuring circuit Fig. 4, TN system)</b>	<= 3.5 mA
<b>Electrical hookup</b>	Terminal box
<b>Protection class</b>	I (with customer connection of protective earth)
<b>Conformity with standards</b>	EN 61800-5-1; CE
<b>Approval</b>	CSA C22.2 No. 77 + CAN/CSA-E60730-1; UL 1004-7 + 60730-1

Product drawing

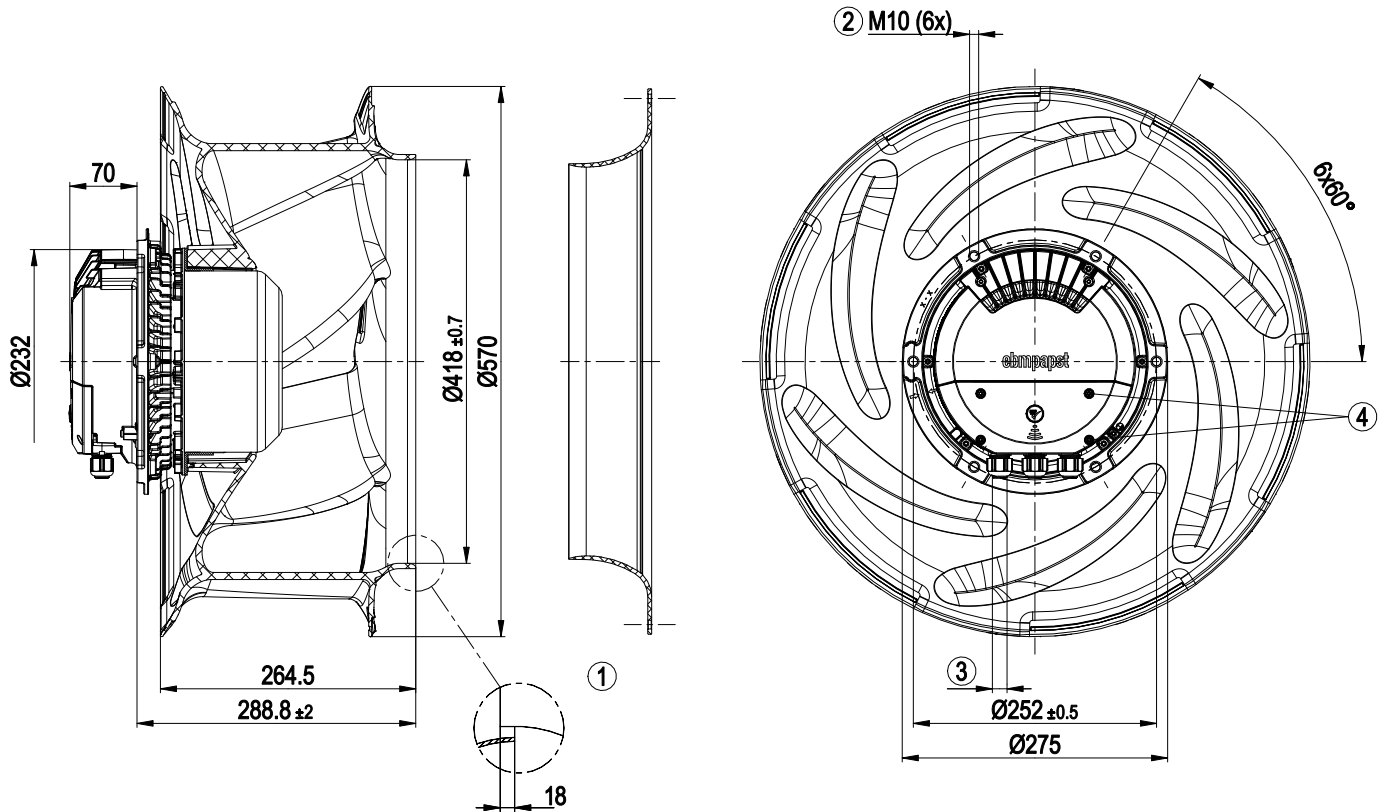

1	Accessory part: Inlet ring 56902-2-2943 not included in scope of delivery
2	Max. clearance for screw 20 mm
3	Cable diameter min. 4 mm, max. 10 mm, tightening torque $4 \pm 0.6$ Nm
4	Tightening torque $1.5 \pm 0.2$ Nm

## Accessory part

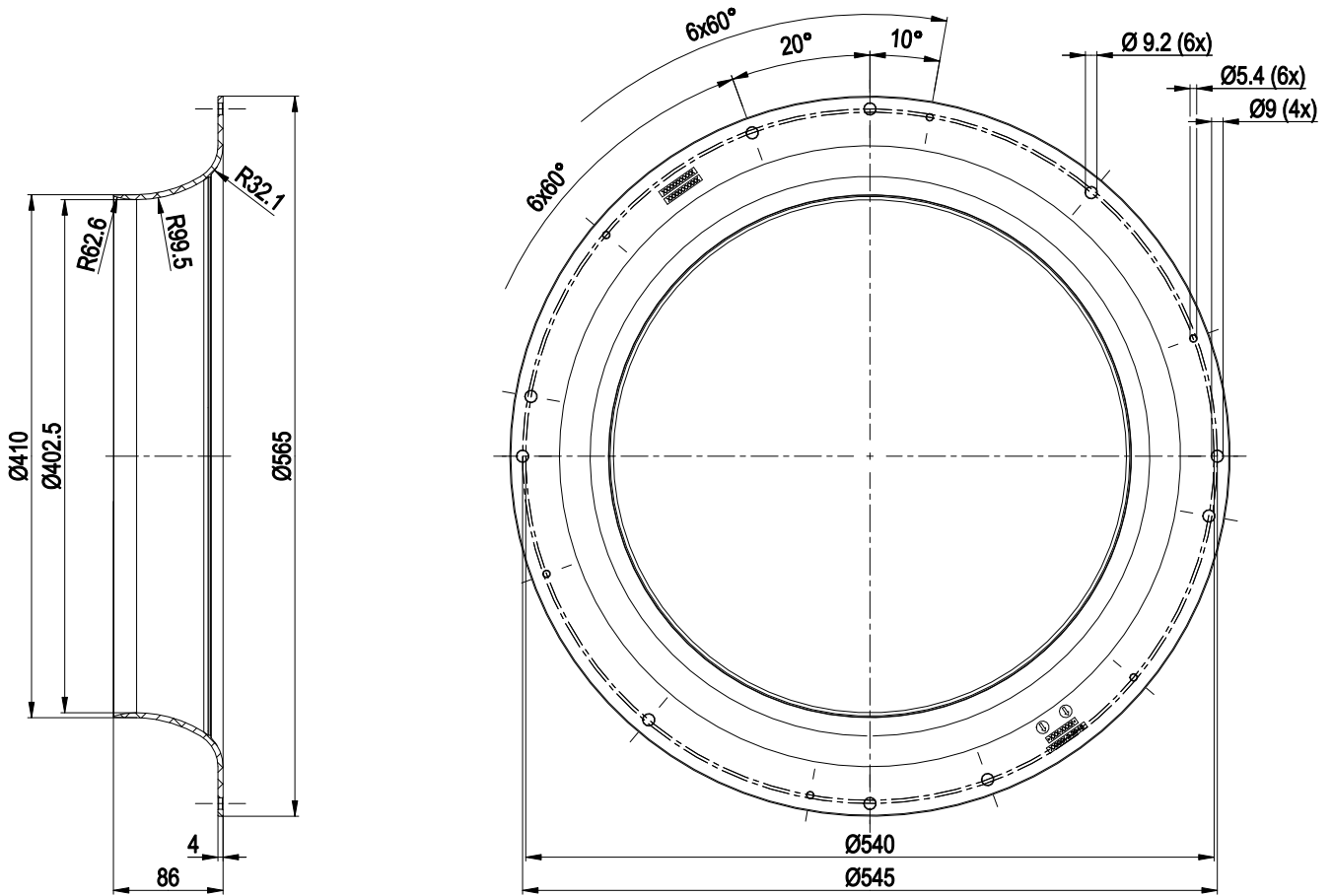

Inlet ring 56902-2-2943 ,tightening torque 5.5±0.8Nm for M5 screw

## Connection diagram

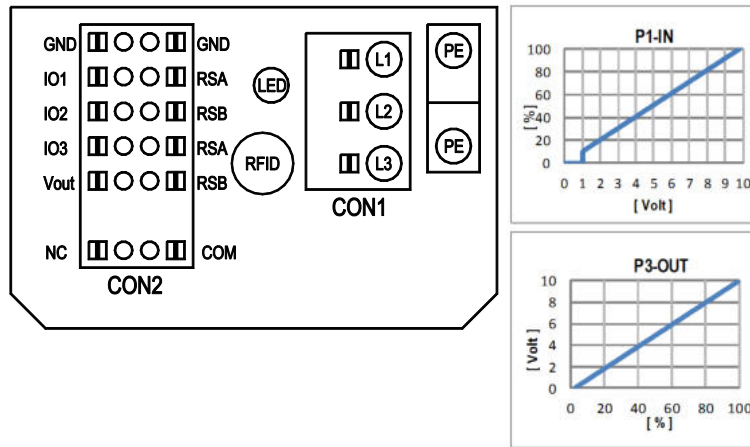

No.	Conn.	Designation	Function/assignment
	CON1	L1, L2, L3	Power supply, phase, see nameplate for voltage range
	PE	PE	Protective earth
	CON2	RSA	RS485 interface for MODBUS, RSA; SELV
	CON2	RSB	RS485 interface for MODBUS, RSB; SELV
	CON2	GND	Reference ground for control interface, SELV
	CON2	IO1	Function parameterizable (see "Optional interface functions" table) Factory setting: Digital input - high active, function: Disable input, SELV - inactive: Pin open or applied voltage < 1.5 VDC - active: applied voltage 3.5-50 VDC Reset function: Triggering of error reset on change of state from "enabled" to "disabled"
	CON2	IO2	Function parameterizable (see "Optional interface functions" table) Factory setting: Analog input 0-10 V / PWM, Ri=100 kΩ, function: Set value Characteristic curve parameterizable (see input characteristic curve P1-IN), SELV
	CON2	IO3	Function parameterizable (see "Optional interface functions" table) Factory setting: Analog output 0-10 V, max. 5 mA, function: Fan modulation level Characteristic curve parameterizable (see output characteristic curve P3-OUT), SELV
	CON2	Vout	Voltage output 3.3-24 VDC ±5%, Pmax=800 mW, voltage parameterizable Factory setting: 10 VDC short-circuit-proof, supply for external devices, SELV alternatively: 15-50 VDC input for parameterization via MODBUS without line voltage
	CON2	COM	Status relay, floating status contact, common connection, contact rating 250 VAC / 2 A (AC1) / min. 10 mA, reinforced insulation on supply side and on control interface side
	CON2	NC	Status relay, floating status contact, break for failure
		LED	green: status = good, ready for operation orange: status = warning red: status = failure
		P1-IN	Input characteristic curve
		P3-OUT	Output characteristic curve

## Terminal/plug assignment

CON2	configurable IO functions: normal / inverse	MODBUS Register for IO mode configuration	electrical specification	configurable IO mode	
				101	102
101	○ Din1 (active high), digital input		not active: pin open or applied voltage < 1.5VDC active: applied voltage 3.5-50VDC, SELV	D158 [0]	source: set value
	○ Ain1 0-10V/PWM: analog input		Ri=100K, characteristic curve parameterizable, f <sub>PWM</sub> =1k..10KHz, SELV	D158 [2]	source: sensor value
	○ Tacho out (open collector output)		U <sub>max</sub> =50VDC, I <sub>max</sub> =20mA, SELV	D158 [5]	switch: parameter set: #1 / #2
	○ Diagnostics out (open collector output)		U <sub>max</sub> =50VDC, I <sub>max</sub> =20mA, SELV	D158 [6]	switch: control function: heating (pos.), cooling (neg.)
102	○ Din2 (active high), digital input		not active: pin open or applied voltage < 1.5VDC active: applied voltage 3.5-50VDC, SELV	D159 [0]	switch: set value source
	○ Ain2 0-10V/PWM: analog input		Ri=100K, characteristic curve parameterizable, f <sub>PWM</sub> =1k..10KHz, SELV	D159 [2]	switch: fan enable / disable
	○ Ain2 4-20mA: analog input		Ri=125R, characteristic curve parameterizable, SELV	D159 [3]	switch: direction of rotation: cw / ccw
	○ Din3 (active high), digital input		not active: pin open or applied voltage < 1.5VDC active: applied voltage 3.5-50VDC, SELV	D15A [0]	switch: tach out
103	○ Din3 (active low), digital input		not active: pin open or applied voltage < 1.5VDC active: applied voltage 3.5-50VDC, SELV	D15A [1]	signal: fan modulation level %
	○ PWMIn3: digital input		not active: pin open or applied voltage < 1.5VDC, SELV active: applied voltage < 1.5VDC, SELV 40Hz - 10KHz, characteristics parameterizable	D15A [7]	signal: actual speed
	○ Aout3 0-10V: analog output		not active: pin open or applied voltage < 1.5VDC, SELV active: applied voltage < 1.5VDC, SELV function parameterizable, max. 5mA, max output frequency 300Hz, SELV	D15A [4]	signal: system modulation level %
	○ Tacho out (pulses), analog output		0-10V max. 5mA, max output frequency 300Hz, SELV	D15A [5]	signal: remote control output 0-10V
RSA RSB	○ Diagnostics out (pulses)		0-10V max. 5mA, max output frequency 300Hz, SELV	D15A [6]	signal: diagnostics out (selected directly via IO mode)
	RS485 bus connection,		MODBUS RTU, specification V6.0, SELV		signal: tach out (selected directly via IO mode)
Vout	voltage output		voltage parameterizable 3.3...24VDC +/- 5.5%, P <sub>max</sub> =800mW, short-circuit-proof, supply for external devices, SELV	D16E [..]	switch: fan enable / disable
	alternatively: input auxiliary power supply for parameterization via RS485/MODBUS RTU without line voltage		15...50VDC		switch: set value source
D101 [..]					source: set value
D147 [..]					source: sensor value
D104 [..]					switch: parameter set: #1 / #2
D12E [..]					switch: control function: heating (pos.), cooling (neg.)
D148 [..]					switch: direction of rotation: cw / ccw
D16C [..]					switch: set value source
D16A [..]					switch: fan enable / disable
(selected directly via IO mode)					signal: tach out
(selected directly via IO mode)					signal: diagnostics out
D130 [0]					signal: fan modulation level %
D130 [1]					signal: actual speed
D130 [2]					signal: system modulation level %
D130 [5]					signal: remote control output 0-10V
D00C [1]					pulse input for auto-addressing
D130 [4]					pulse output for auto-addressing

○ configurable option

For further information and additional functions see EC Control Software, Fan-Set-App, or MODBUS Parameter Specification V6.0



## Curves: Air performance 50 Hz

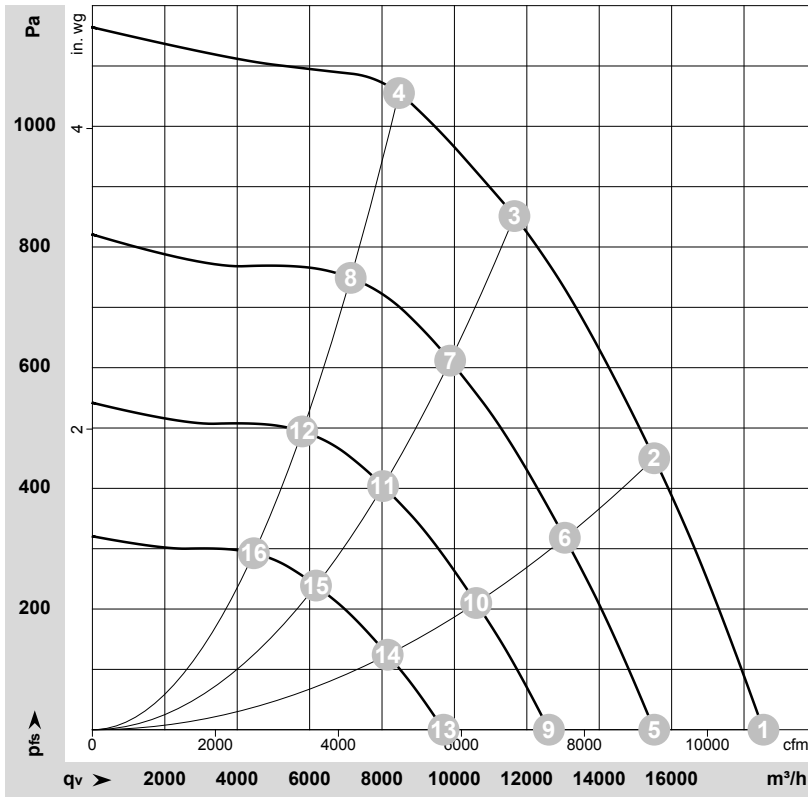

$\rho = 1.15 \text{ kg/m}^3 \pm 2 \%$

Measurement: 13459

Air performance measured according to ISO 5801 installation category A. For detailed information on the measurement setup, contact ebm-papst. Intake sound level: Sound power level according to ISO 13347 / sound pressure level measured at 1 m distance from fan axis. The values given are valid under the specified measuring conditions and may vary due to conditions of installation. For deviations from the standard configuration, the parameters have to be checked on the installed unit.

## Fan Performance

	Wired	U	f	n	P <sub>ed</sub>	I	LpA <sub>in</sub>	LwA <sub>in</sub>	LwA <sub>out</sub>	q <sub>v</sub>	P <sub>fs</sub>	q <sub>v</sub>	P <sub>fs</sub>
		V	Hz	min <sup>-1</sup>	W	A	dB(A)	dB(A)	dB(A)	m <sup>3</sup> /h	Pa	cfm	in. wg
1	3~	400	50	1900	2299	3.57	91	97	101	18535	0	10910	0.00
2	3~	400	50	1900	3480	5.32	88	92	96	15520	450	9135	1.81
3	3~	400	50	1900	3950	6.00	72	80	86	11660	850	6860	3.41
4	3~	400	50	1900	3950	6.00	77	84	89	8470	1050	4985	4.22
5	3~	400	50	1600	1349	2.10	86	92	96	15520	0	9135	0.00
6	3~	400	50	1600	2065	3.16	84	87	92	13050	320	7680	1.28
7	3~	400	50	1600	2404	3.67	68	75	82	9880	612	5815	2.46
8	3~	400	50	1600	2359	3.60	73	80	84	7135	749	4200	3.01
9	3~	400	50	1300	724	1.12	81	87	91	12610	0	7420	0.00
10	3~	400	50	1300	1108	1.69	78	82	86	10605	212	6240	0.85
11	3~	400	50	1300	1289	1.97	63	70	76	8030	404	4725	1.62
12	3~	400	50	1300	1265	1.93	68	74	79	5795	495	3410	1.99
13	3~	400	50	1000	329	0.51	74	80	85	9700	0	5710	0.00
14	3~	400	50	1000	504	0.77	72	75	80	8155	125	4800	0.50
15	3~	400	50	1000	587	0.90	56	64	70	6175	239	3635	0.96
16	3~	400	50	1000	576	0.88	61	68	73	4460	293	2625	1.18

Wired = Wiring · U = Voltage · f = Frequency · n = Speed (rpm) · P<sub>ed</sub> = Power consumption · I = Current draw · LpA<sub>in</sub> = Sound pressure level intake side · LwA<sub>in</sub> = Sound power level intake side  
LwA<sub>out</sub> = Sound power level outlet side · q<sub>v</sub> = Air flow · P<sub>fs</sub> = Pressure increase

