

R3G500-RL96-08 ebmpapst Datasheet

sales@fansco.com

www.fansco.com

Limited partnership · Headquarters Mulfingen

Amtsgericht (court of registration) Stuttgart · HRA 590344

General partner Elektrobau Mulfingen GmbH · Headquarters Mulfingen

Amtsgericht (court of registration) Stuttgart · HRB 590142

## Nominal data

|                          |                   |            |
|--------------------------|-------------------|------------|
| Type                     | R3G500-RL96-08    |            |
| Motor                    | M3G112-IA         |            |
| Phase                    |                   | 3~         |
| Nominal voltage          | VAC               | 400        |
| Nominal voltage range    | VAC               | 380 .. 480 |
| Frequency                | Hz                | 50/60      |
| Method of obtaining data |                   | ml         |
| Speed (rpm)              | min <sup>-1</sup> | 1400       |
| Power consumption        | W                 | 1320       |
| Current draw             | A                 | 2.1        |
| Min. ambient temperature | °C                | -25        |
| Max. ambient temperature | °C                | 55         |

ml = Max. load · me = Max. efficiency · fa = Free air · cs = Customer specification · ce = Customer equipment  
Subject to change

## Data according to Commission Regulation (EU) 327/2011

|                                   |   | Actual | Req. 2015 |                                |                   |      |
|-----------------------------------|---|--------|-----------|--------------------------------|-------------------|------|
| 01 Overall efficiency $\eta_{es}$ | % | 62.8   | 52.7      | 09 Power consumption $P_{ed}$  | kW                | 1.3  |
| 02 Measurement category           |   | A      |           | 09 Air flow $q_v$              | m <sup>3</sup> /h | 6215 |
| 03 Efficiency category            |   | Static |           | 09 Pressure increase $p_{fs}$  | Pa                | 463  |
| 04 Efficiency grade N             |   | 72.1   | 62        | 10 Speed (rpm) n               | min <sup>-1</sup> | 1345 |
| 05 Variable speed drive           |   | Yes    |           | 11 Specific ratio <sup>*</sup> |                   | 1.00 |

Data obtained at optimum efficiency level.

The ErP data is determined using a motor-impeller combination in a standardized measurement setup.

<sup>\*</sup> Specific ratio =  $1 + p_{fs} / 100\,000\text{ Pa}$ 

LU-185645



## Technical description

|  |  |
|--|--|
| Weight   | 14.2 kg  |
| Size   | 500 mm   |
| Motor size   | 112  |
| Rotor surface  | Painted black  |
| Electronics housing material   | Die-cast aluminum  |
| Impeller material  | PP plastic   |
| Number of blades   | 7  |
| Direction of rotation  | Clockwise, viewed toward rotor   |
| Degree of protection   | IP55   |
| Insulation class   | "F"  |
| Moisture (F) / Environmental (H) protection class                          | H1   |
| Ambient temperature note   | Occasional start-up between -40°C and -25°C is permissible.<br>For continuous operation at temperatures below -25°C (e.g. refrigeration applications) we recommend our fan design with special low-temperature bearings.   |
| Max. permitted ambient temp. for motor (transport/storage)                 | +80 °C   |
| Min. permitted ambient temp. for motor (transport/storage)                 | -40 °C   |
| Installation position  | Shaft horizontal or rotor on bottom; rotor on top on request   |
| Condensation drainage holes  | On rotor side  |
| Mode   | S1   |
| Motor bearing  | Ball bearing; (sealed)   |
| Technical features   | <ul style="list-style-type: none"> <li>- Output 10 VDC, max. 10 mA</li> <li>- Operation and alarm display</li> <li>- External 24 V input (parameter setting)</li> <li>- Alarm relay</li> <li>- Integrated PID controller</li> <li>- Motor current limitation</li> <li>- PFC, passive</li> <li>- RS-485 MODBUS-RTU</li> <li>- Soft start</li> <li>- EEPROM write cycles: 100,000 maximum</li> <li>- Control input 0-10 VDC / PWM</li> <li>- Control interface with SELV potential safely disconnected from the mains</li> <li>- Thermal overload protection for electronics/motor</li> <li>- Line undervoltage / phase failure detection</li> </ul> |
| EMC immunity to interference   | According to EN 61000-6-2 (industrial environment)   |
| EMC interference emission  | According to EN 61000-6-3 (household environment), except EN 61000-3-2 for professionally used equipment with a total rated power greater than 1 kW  |
| Touch current according to IEC 60990 (measuring circuit Fig. 4, TN system) | <= 3.5 mA  |
| Motor protection   | Thermal overload protector (TOP) internally connected  |
| With cable   | Variable   |
| Protection class   | I (with customer connection of protective earth)   |
| Conformity with standards  | EN 61800-5-1; EN 60335-1; CE   |
| Approval   | CSA C22.2 No. 77 + CAN/CSA-E60730-1; EAC; UL 1004-7 + 60730  |

Product drawing

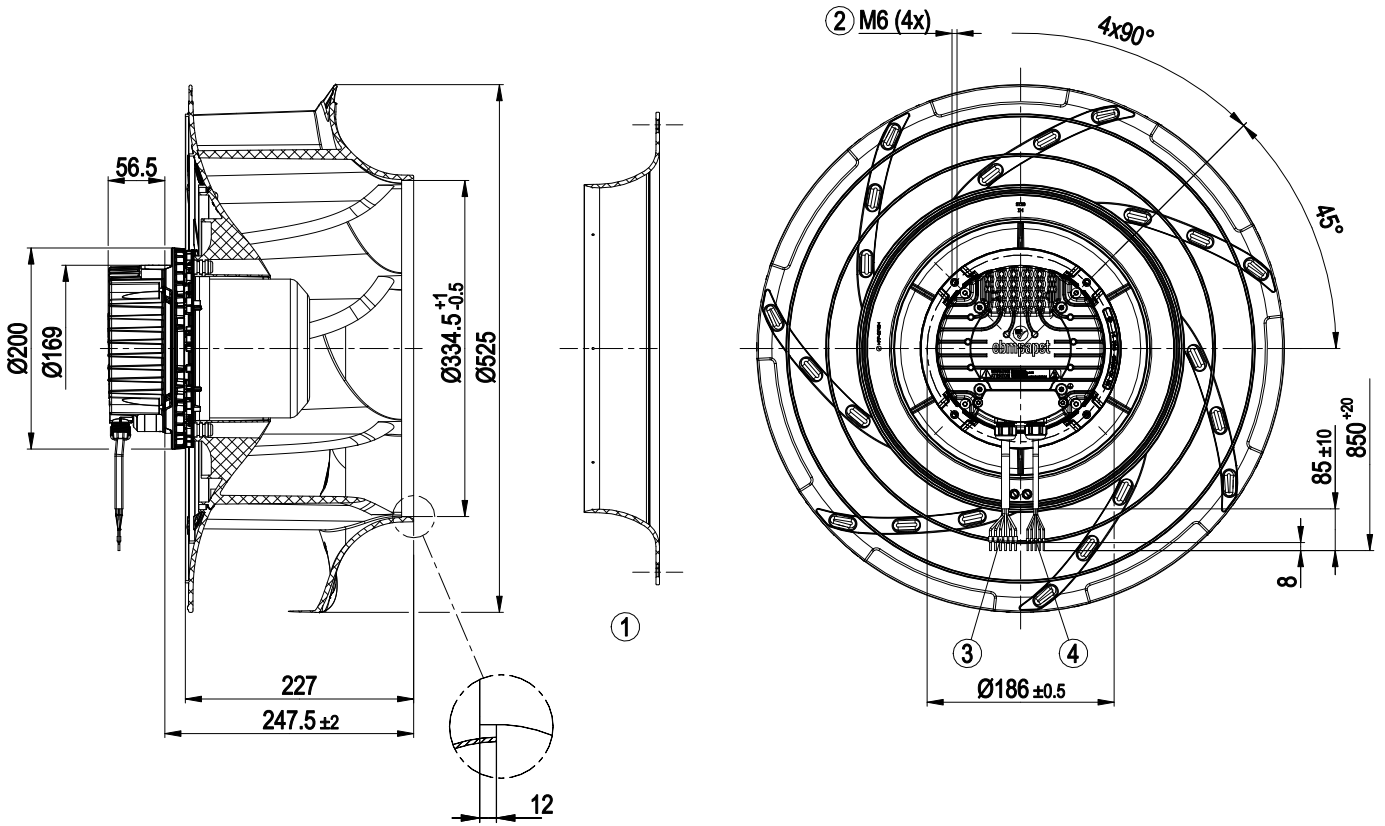

|   |   |
|---|---|
| 1 | Accessory part: inlet ring 50901-2-2943 not included in scope of delivery |
| 2 | Max. clearance for screw 16 mm  |
| 3 | Cable PVC AWG18, 6x crimped ferrules                                      |
| 4 | Cable PVC AWG22, 5x crimped ferrules                                      |



Accessory part

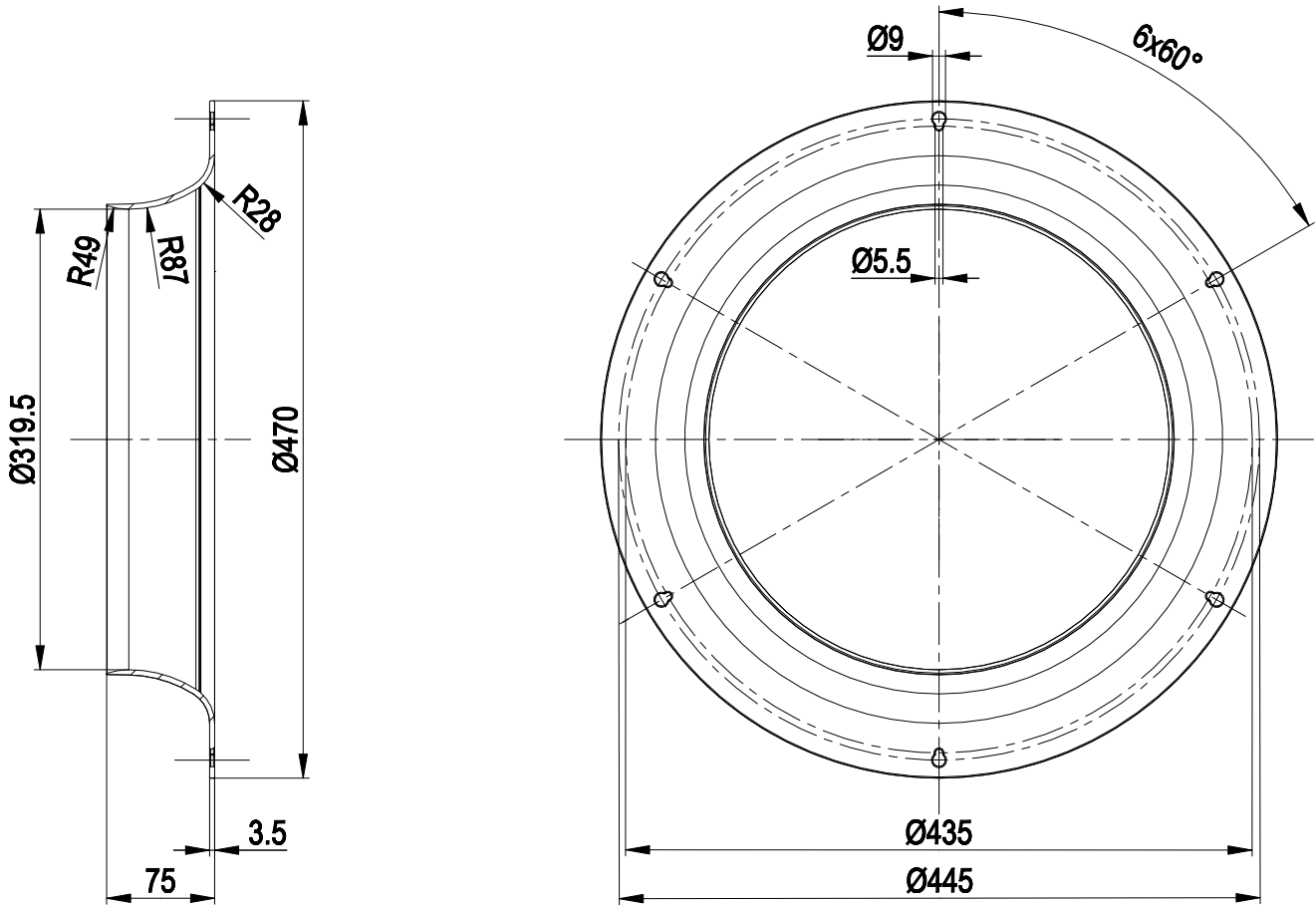

1 Accessory part: inlet ring 50901-2-2943



## Connection diagram

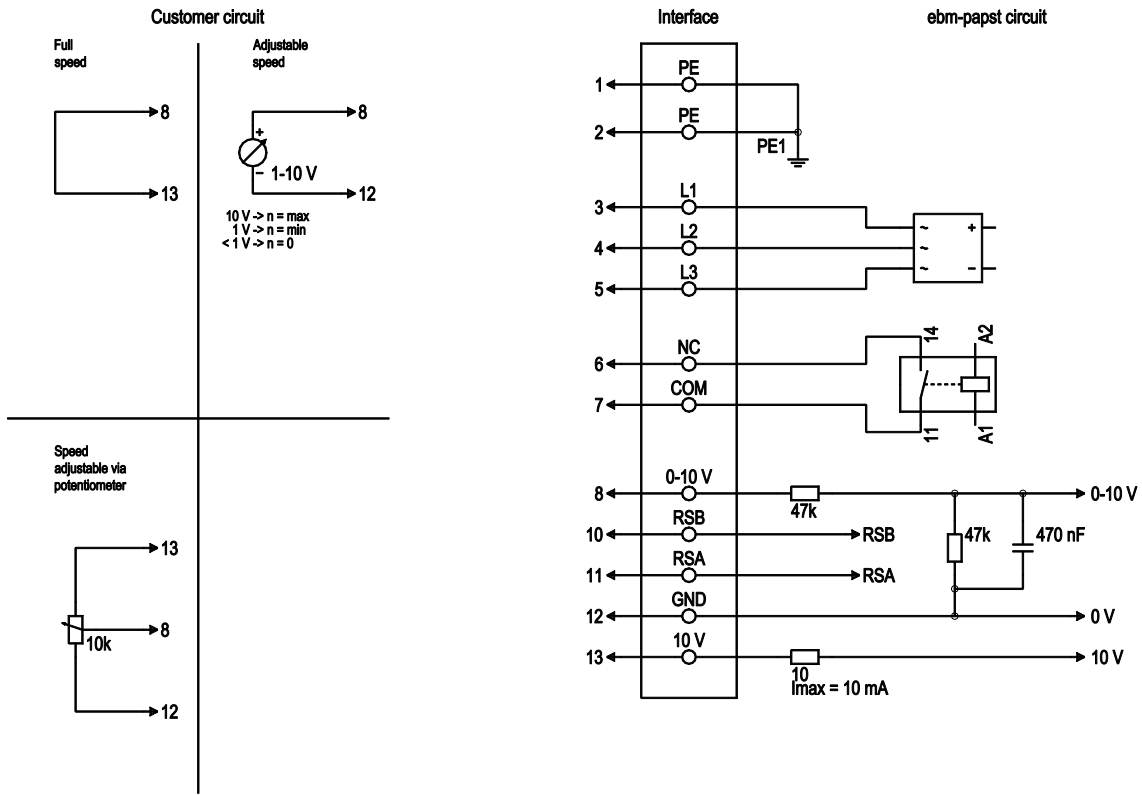

| No. | Conn. | Designation | Color        | Function/assignment  |
|-----|-------|-------------|--------------|--|
| 1   | 1, 2  | PE          | green/yellow | Protective earth   |
| 1   | 3     | L1          | black        | Power supply   |
| 1   | 4     | L2          | black        | Power supply   |
| 1   | 5     | L3          | black        | Power supply   |
| 1   | 6     | NC          | white 1      | Status relay, floating status contact, break for failure, contact rating 250 VAC / 2 A (AC1) / min. 10 mA; reinforced insulation on supply side and basic insulation on control interface side                                       |
| 1   | 7     | COM         | white 2      | Status relay, floating status contact, break for failure, contact rating 250 VAC / 2 A (AC1) / min. 10 mA; reinforced insulation on supply side and basic insulation on control interface side                                       |
| 2   | 8     | 0-10V       | yellow       | Analog input (set value), 0-10 V, $R_i = 100\text{ k}\Omega$ , adjustable curve, SELV  |
| 2   | 10    | RSB         | brown        | RS485 interface for MODBUS, RSB; SELV  |
| 2   | 11    | RSA         | white        | RS485 interface for MODBUS, RSA; SELV  |
| 2   | 12    | GND         | blue         | Reference ground for control interface, SELV   |
| 2   | 13    | +10V        | red          | Fixed voltage output 10 VDC, $+10\text{ V} \pm 3\%$ , max. 10 mA, short-circuit-proof power supply for external devices (e.g. pot), SELV<br>fixed voltage input 24 VDC for setting parameters via MODBUS without line voltage supply |



## Curves: Air performance 50 Hz

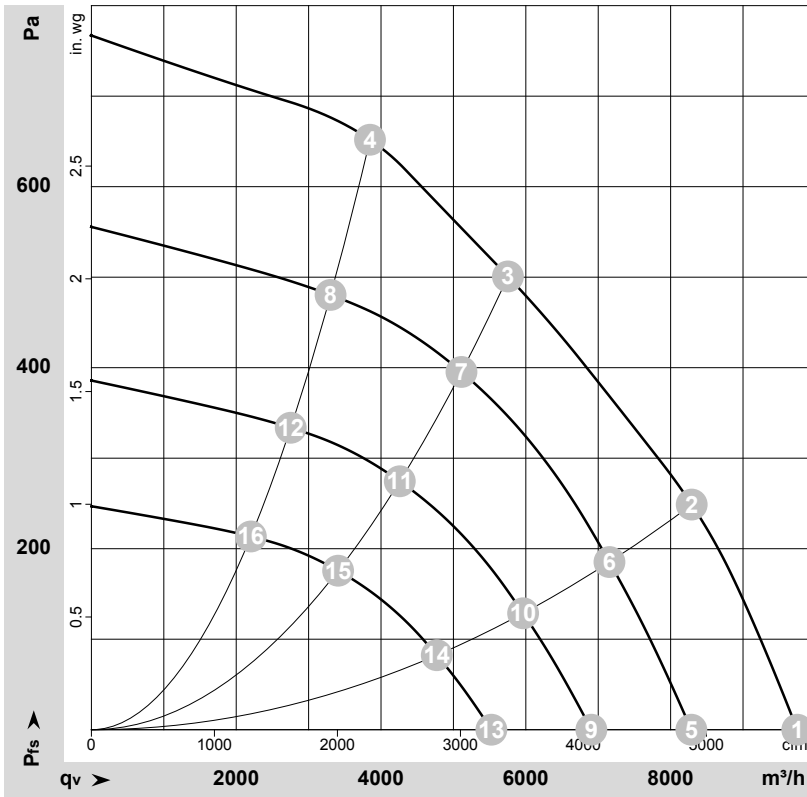

$\rho = 1.15 \text{ kg/m}^3 \pm 2 \%$

Measurement: LU-185645-1

Air performance measured according to ISO 5801 installation category A. For detailed information on the measurement setup, contact ebmpapst. Intake sound level: Sound power level according to ISO 13347 / sound pressure level measured at 1 m distance from fan axis. The values given are valid under the specified measuring conditions and may vary due to conditions of installation. For deviations from the standard configuration, the parameters have to be checked on the installed unit.

## Measured values

|    | U   | f  | n                 | P <sub>ed</sub> | I    | LpA <sub>in</sub> | LwA <sub>in</sub> | LwA <sub>out</sub> | q <sub>v</sub>    | P <sub>fs</sub> | q <sub>v</sub> | P <sub>fs</sub> |
|----|-----|----|-------------------|-----------------|------|-------------------|-------------------|--------------------|-------------------|-----------------|----------------|-----------------|
|    | V   | Hz | min <sup>-1</sup> | W               | A    | dB(A)             | dB(A)             | dB(A)              | m <sup>3</sup> /h | Pa              | cfm            | in. wg          |
| 1  | 400 | 50 | 1400              | 1035            | 1.60 | 73                | 80                | 86                 | 9750              | 0               | 5740           | 0.00            |
| 2  | 400 | 50 | 1400              | 1320            | 2.10 | 70                | 77                | 83                 | 8290              | 250             | 4880           | 1.00            |
| 3  | 400 | 50 | 1400              | 1320            | 2.10 | 63                | 70                | 77                 | 5755              | 500             | 3385           | 2.01            |
| 4  | 400 | 50 | 1400              | 1299            | 1.99 | 66                | 74                | 79                 | 3850              | 650             | 2265           | 2.61            |
| 5  | 400 | 50 | 1200              | 635             | 0.98 | 69                | 76                | 82                 | 8285              | 0               | 4875           | 0.00            |
| 6  | 400 | 50 | 1200              | 845             | 1.29 | 66                | 73                | 80                 | 7155              | 186             | 4210           | 0.75            |
| 7  | 400 | 50 | 1200              | 917             | 1.40 | 60                | 68                | 74                 | 5110              | 396             | 3010           | 1.59            |
| 8  | 400 | 50 | 1200              | 814             | 1.25 | 62                | 70                | 75                 | 3305              | 482             | 1945           | 1.94            |
| 9  | 400 | 50 | 1000              | 368             | 0.57 | 64                | 71                | 78                 | 6905              | 0               | 4065           | 0.00            |
| 10 | 400 | 50 | 1000              | 489             | 0.75 | 61                | 68                | 75                 | 5965              | 129             | 3510           | 0.52            |
| 11 | 400 | 50 | 1000              | 530             | 0.81 | 55                | 63                | 69                 | 4260              | 275             | 2505           | 1.10            |
| 12 | 400 | 50 | 1000              | 471             | 0.72 | 58                | 66                | 71                 | 2755              | 335             | 1620           | 1.34            |
| 13 | 400 | 50 | 800               | 188             | 0.29 | 58                | 66                | 72                 | 5525              | 0               | 3250           | 0.00            |
| 14 | 400 | 50 | 800               | 250             | 0.38 | 56                | 63                | 69                 | 4770              | 83              | 2810           | 0.33            |
| 15 | 400 | 50 | 800               | 272             | 0.42 | 50                | 57                | 64                 | 3405              | 176             | 2005           | 0.71            |
| 16 | 400 | 50 | 800               | 241             | 0.37 | 52                | 60                | 65                 | 2200              | 214             | 1295           | 0.86            |

U = Voltage · f = Frequency · n = Speed (rpm) · P<sub>ed</sub> = Power consumption · I = Current draw · LpA<sub>in</sub> = Sound pressure level intake side · LwA<sub>in</sub> = Sound power level intake side  
 LwA<sub>out</sub> = Sound power level outlet side · q<sub>v</sub> = Air flow · P<sub>fs</sub> = Pressure increase

