

R3G500-RH32-25 ebmpapst Datasheet

sales@fansco.com

www.fansco.com

## Nominal data

Type	R3G500-RH32-25	
Motor	M3G112-GA	
Phase		1~
Nominal voltage	VAC	230
Nominal voltage range	VAC	200 .. 277
Frequency	Hz	50/60
Method of obtaining data		ml
Speed (rpm)	min <sup>-1</sup>	1080
Power consumption	W	690
Current draw	A	3.1
Min. ambient temperature	°C	-25
Max. ambient temperature	°C	55

ml = Max. load · me = Max. efficiency · fa = Free air · cs = Customer specification · ce = Customer equipment  
Subject to change

## Data according to Commission Regulation (EU) 327/2011

		Actual	Req. 2015
01 Overall efficiency $\eta_{es}$	%	62.6	49.7
02 Measurement category		A	
03 Efficiency category		Static	
04 Efficiency grade N		74.9	62
05 Variable speed drive		Yes	

Data obtained at optimum efficiency level.

The ErP data is determined using a motor-impeller combination in a standardized measurement setup.

09 Power consumption $P_{ed}$	kW	0.68
09 Air flow $q_v$	m <sup>3</sup> /h	4580
09 Pressure increase $p_{fs}$	Pa	306
10 Speed (rpm) $n$	min <sup>-1</sup>	1070
11 Specific ratio <sup>*</sup>		1.00

<sup>\*</sup> Specific ratio =  $1 + p_{fs} / 100\,000\text{ Pa}$

LU-127822



## Technical description

Weight	13.1 kg
Size	500 mm
Motor size	112
Rotor surface	Painted black
Electronics housing material	Die-cast aluminum
Impeller material	PP plastic
Number of blades	7
Direction of rotation	Clockwise, viewed toward rotor
Degree of protection	IP54
Insulation class	"B"
Moisture (F) / Environmental (H) protection class	H1
Max. permitted ambient temp. for motor (transport/storage)	+80 °C
Min. permitted ambient temp. for motor (transport/storage)	-40 °C
Installation position	Shaft horizontal or rotor on top; rotor on bottom on request
Condensation drainage holes	On stator side
Mode	S1
Motor bearing	Ball bearing
Technical features	<ul style="list-style-type: none"> <li>- Output 10 VDC, max. 10 mA</li> <li>- Alarm relay</li> <li>- Motor current limitation</li> <li>- PFC, active</li> <li>- Soft start</li> <li>- Control input 0-10 VDC</li> <li>- Control interface with SELV potential safely disconnected from the mains</li> <li>- Thermal overload protection for electronics/motor</li> <li>- Line undervoltage / phase failure detection</li> </ul>
EMC immunity to interference	According to EN 61000-6-2 (industrial environment)
EMC circuit feedback	According to EN 61000-3-2/3
EMC interference emission	According to EN 61000-6-4 (industrial environment)
Touch current according to IEC 60990 (measuring circuit Fig. 4, TN system)	<= 3.5 mA
Motor protection	Thermal overload protector (TOP) internally connected
With cable	Variable
Protection class	I (with customer connection of protective earth)
Conformity with standards	CE

Product drawing

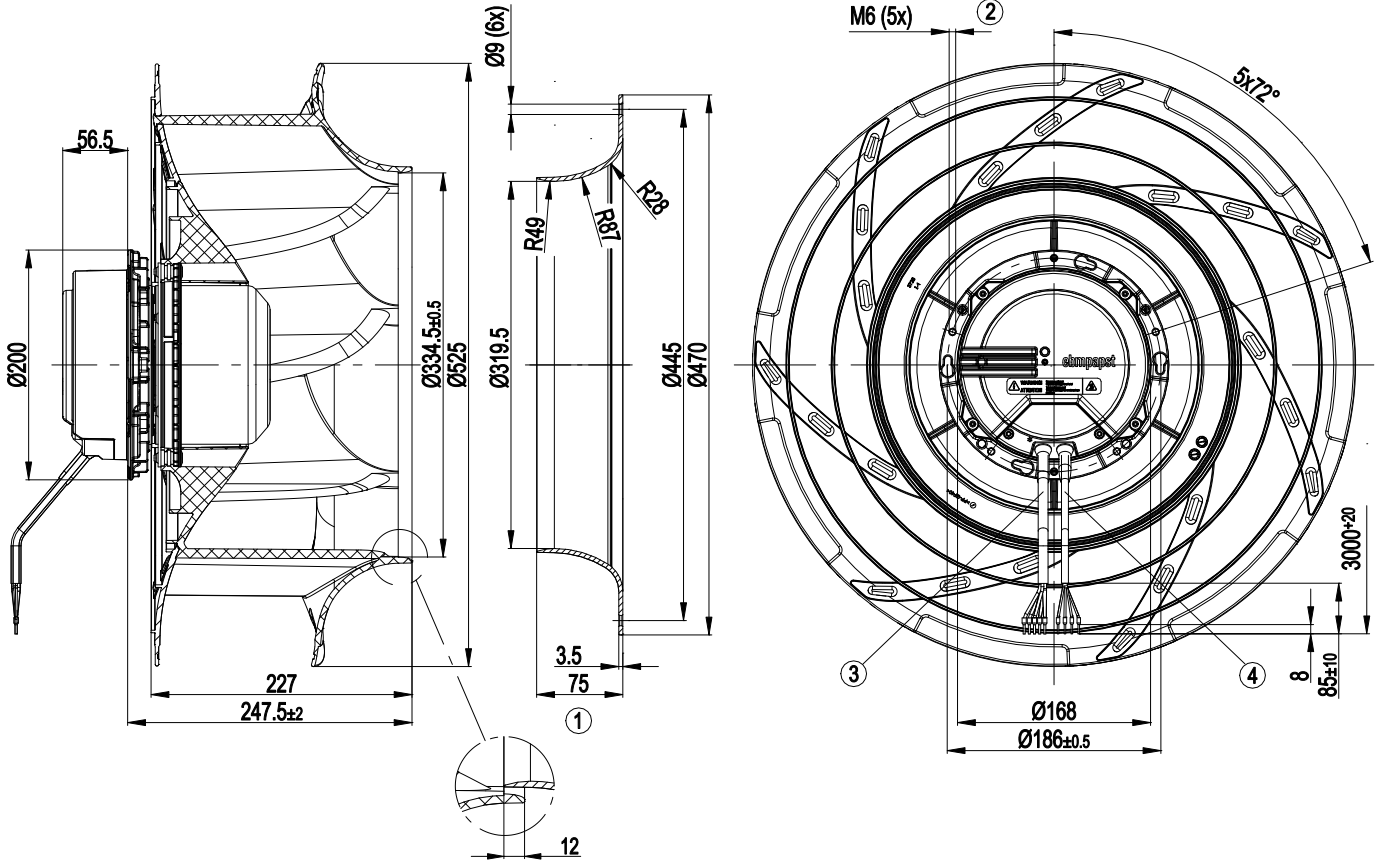

1	Accessory part: Inlet ring 50901-2-2943 not included in scope of delivery.
2	Clearance for screw 12-16 mm
3	Cable AWG 18, 5x crimped splices
4	Cable AWG 22, 4x crimped splices



## Connection diagram

### Customer circuit

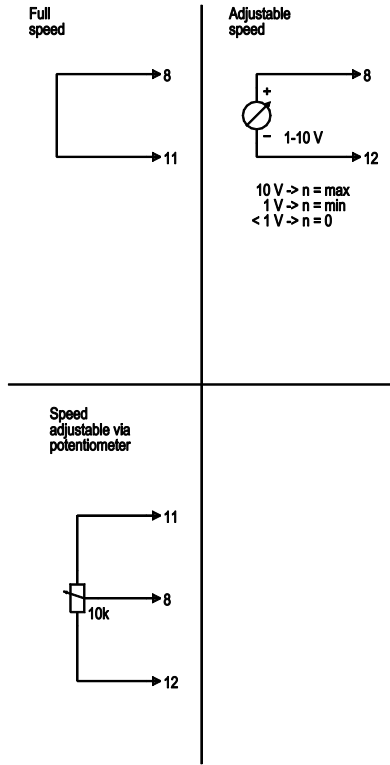

### Connection

### Fan / Motor

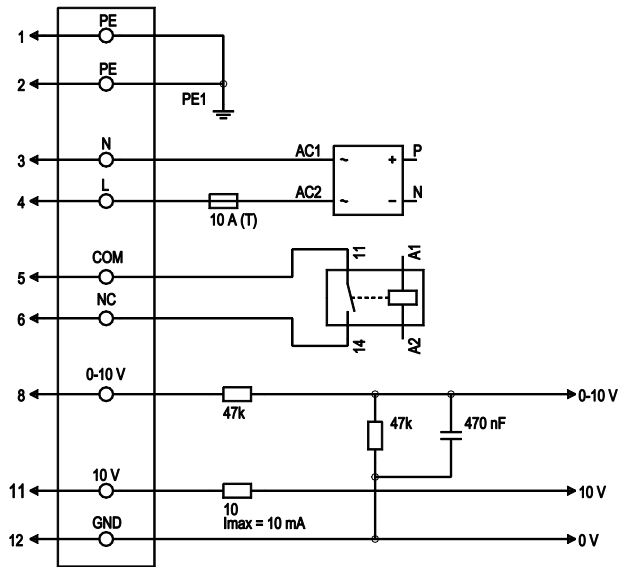

No.	Conn.	Designation	Color	Function/assignment
1	1,2	PE	green/yellow	Protective earth
1	3	N	blue	Power supply, neutral conductor, 50/60 Hz
1	4	L	black	Power supply, phase, 50/60 Hz
1	5	COM	white 1	Floating status contact, break for failure (2 A, max. 250 VAC, min. 10 mA, AC1)
1	6	NC	white 2	Floating status contact, break for failure
2	8	0-10 V	yellow	Control input, set value 0-10 VDC, impedance 100 kΩ, SELV
2	11	10 VDC	red	Voltage output 10 VDC (±3%), max. 10 mA, power supply for external devices (e.g. potentiometer), SELV
2	12	GND	blue	Reference ground for control interface, SELV



## Curves: Air performance 50 Hz

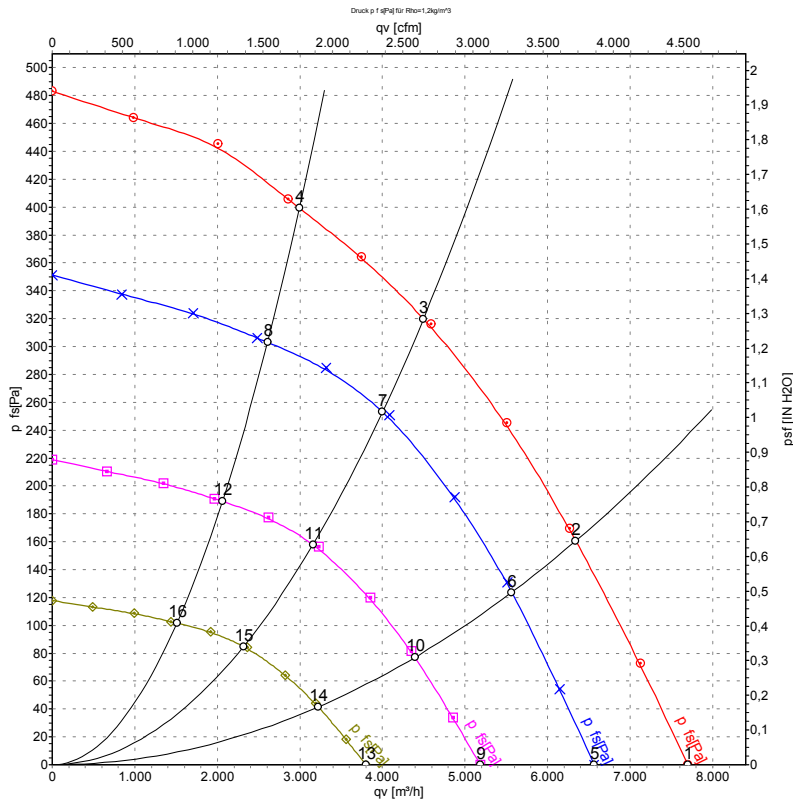

Measurement: LU-137835-1

Air performance measured according to ISO 5801 installation category A. For detailed information on the measurement setup, contact ebmpapst. Intake sound level: Sound power level according to ISO 13347 / sound pressure level measured at 1 m distance from fan axis. The values given are valid under the specified measuring conditions and may vary due to conditions of installation. For deviations from the standard configuration, the parameters have to be checked on the installed unit.

## Measured values

	U	f	n	P <sub>ed</sub>	I	LpA <sub>in</sub>	LwA <sub>in</sub>	LwA <sub>out</sub>	q <sub>v</sub>	P <sub>fs</sub>	q <sub>v</sub>	P <sub>fs</sub>
	V	Hz	min <sup>-1</sup>	W	A	dB(A)	dB(A)	dB(A)	m <sup>3</sup> /h	Pa	cfm	in. wg
1	230	50	1080	538	2.44	67	74	81	7700	0	4535	0.00
2	230	50	1080	647	2.90	63	70	77	6340	160	3730	0.64
3	230	50	1080	690	3.10	57	65	71	4495	320	2645	1.28
4	230	50	1080	642	2.86	58	65	71	2995	400	1765	1.61
5	230	50	950	334	1.51	64	71	77	6565	0	3865	0.00
6	230	50	950	439	1.97	60	67	74	5565	125	3275	0.50
7	230	50	950	490	2.18	55	62	68	4000	255	2355	1.02
8	230	50	950	425	1.90	55	62	68	2610	303	1535	1.22
9	230	50	750	164	0.74	58	66	72	5185	0	3050	0.00
10	230	50	750	216	0.97	55	62	69	4395	78	2585	0.31
11	230	50	750	241	1.07	50	57	63	3160	159	1860	0.64
12	230	50	750	209	0.93	50	57	63	2060	189	1210	0.76
13	230	50	550	65	0.29	52	59	65	3800	0	2240	0.00
14	230	50	550	85	0.38	48	56	62	3220	42	1895	0.17
15	230	50	550	95	0.42	43	50	56	2315	85	1365	0.34
16	230	50	550	83	0.37	43	51	56	1510	102	890	0.41

U = Voltage · f = Frequency · n = Speed (rpm) · P<sub>ed</sub> = Power consumption · I = Current draw · LpA<sub>in</sub> = Sound pressure level intake side · LwA<sub>in</sub> = Sound power level intake side  
 LwA<sub>out</sub> = Sound power level outlet side · q<sub>v</sub> = Air flow · P<sub>fs</sub> = Pressure increase

