

R3G500-FK56-01 ebmpapst Datasheet

sales@fansco.com

www.fansco.com

Limited partnership · Headquarters Muldingen

Amtsgericht (court of registration) Stuttgart · HRA 590344

General partner Elektrobau Muldingen GmbH · Headquarters Muldingen

Amtsgericht (court of registration) Stuttgart · HRB 590142

Nominal data

Type	R3G500-FK56-01	
Motor	M3G112-GA	
Phase		3~
Nominal voltage	VAC	400
Nominal voltage range	VAC	380 .. 480
Frequency	Hz	50/60
Method of obtaining data		ml
Speed (rpm)	min ⁻¹	1460
Power consumption	W	1320
Current draw	A	2.0
Min. ambient temperature	°C	-40
Max. ambient temperature	°C	40

ml = Max. load · me = Max. efficiency · fa = Free air · cs = Customer specification · ce = Customer equipment
Subject to change

Data according to Commission Regulation (EU) 327/2011 (EN 17166)

		Actual	Req. 2015			
01 Overall efficiency η_{es}	%	71.6	52.6	09 Power consumption P_{ed}	kW	1.28
02 Measurement category		A		09 Air flow q_v	m ³ /h	6680
03 Efficiency category		Static		09 Pressure increase p_{fs}	Pa	460
04 Efficiency grade N		81	62	10 Speed (rpm) n	min ⁻¹	1460
05 Variable speed drive		Yes		11 Specific ratio [*]		1.00

Data obtained at optimum efficiency level.

^{*} Specific ratio = $1 + p_g / 100\,000\text{ Pa}$

LU-214301

The efficiency values displayed for achieving conformity with the Ecodesign Regulation EU 327/2011 has been reached with defined air duct components (e.g. inlet rings). The dimensions must be requested from ebm-papst. If other air conduction geometries are used on the installation side, the ebm-papst evaluation loses its validity/the conformity must be confirmed again. The product does not fall within the scope of Regulation (EU) 2019/1781 due to the exception specified in Article 2 (2a) (motors completely integrated into a product).



Technical description

Weight	12.14 kg
Size	500 mm
Motor size	112
Rotor surface	Painted black
Electronics housing material	Die-cast aluminum
Impeller material	PP plastic
Number of blades	6
Direction of rotation	Clockwise, viewed toward rotor
Degree of protection	IP55
Insulation class	"F"
Moisture (F) / Environmental (H) protection class	H1
Ambient temperature note	Occasional start-up at temperatures between -40°C and -25°C is permitted. For continuous operation at ambient temperatures below -25°C (such as refrigeration applications), use must be made of a fan design with special low-temperature bearings.
Max. permitted ambient temp. for motor (transport/storage)	+80 °C
Min. permitted ambient temp. for motor (transport/storage)	-40 °C
Installation position	Shaft horizontal or rotor on bottom; rotor on top on request
Condensation drainage holes	On rotor side
Mode	S1
Motor bearing	Ball bearing
Technical features	<ul style="list-style-type: none"> - Output 10 VDC, max. 10 mA - Operation and alarm display - External 24 V input (parameter setting) - Alarm relay - Integrated PID controller - MODBUS V5.1 - Motor current limitation - PFC, passive - RS-485 MODBUS-RTU - Soft start - EEPROM write cycles: 100,000 maximum - Control input 0-10 VDC / PWM - Control interface with SELV potential safely disconnected from the mains - Thermal overload protection for electronics/motor - Line undervoltage / phase failure detection
EMC immunity to interference	According to EN 61000-6-2 (industrial environment)
EMC interference emission	According to EN 61000-6-3 (household environment), except EN 61000-3-2 for professionally used equipment with a total rated power greater than 1 kW
Touch current according to IEC 60990 (measuring circuit Fig. 4, TN system)	<= 3.5 mA
Motor protection	Thermal overload protector (TOP) internally connected
With cable	Variable

Protection class assignment	I; If a protective earth is connected by the customer This component for installation may have several local protection classes. This information relates to this component's basic design. The final protection class is based on the component's intended installation and connection.
Conformity with standards	EN 61800-5-1; CE
Approval	EAC



Product drawing

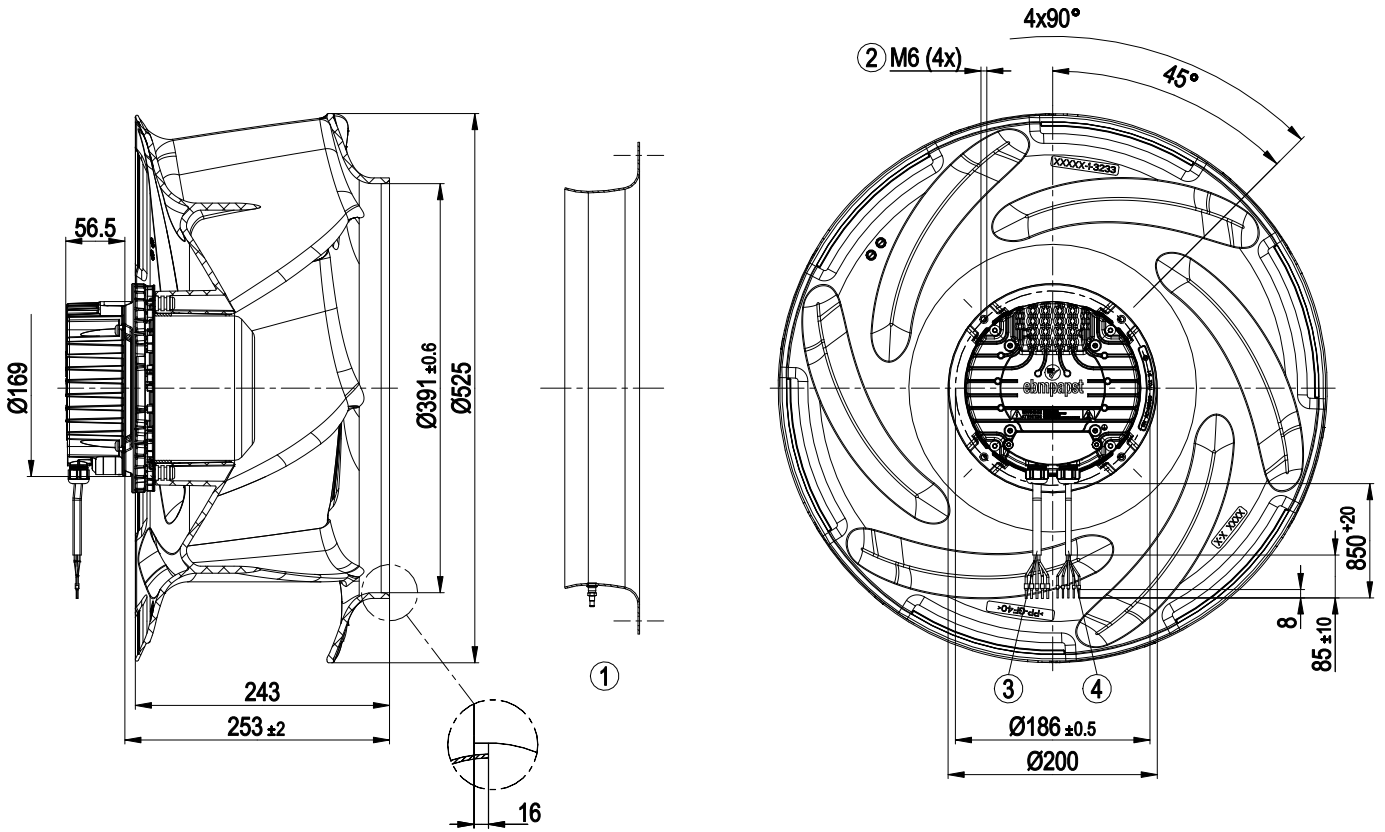

1	Accessory part: Inlet ring 50355-2-4013 with pressure tap (k-factor: 375) not included in scope of delivery
2	Max. clearance for screw 16 mm
3	Cable PVC AWG18 6x wire-end ferrule
4	Cable PVC AWG22 5x wire-end ferrule



Accessory part

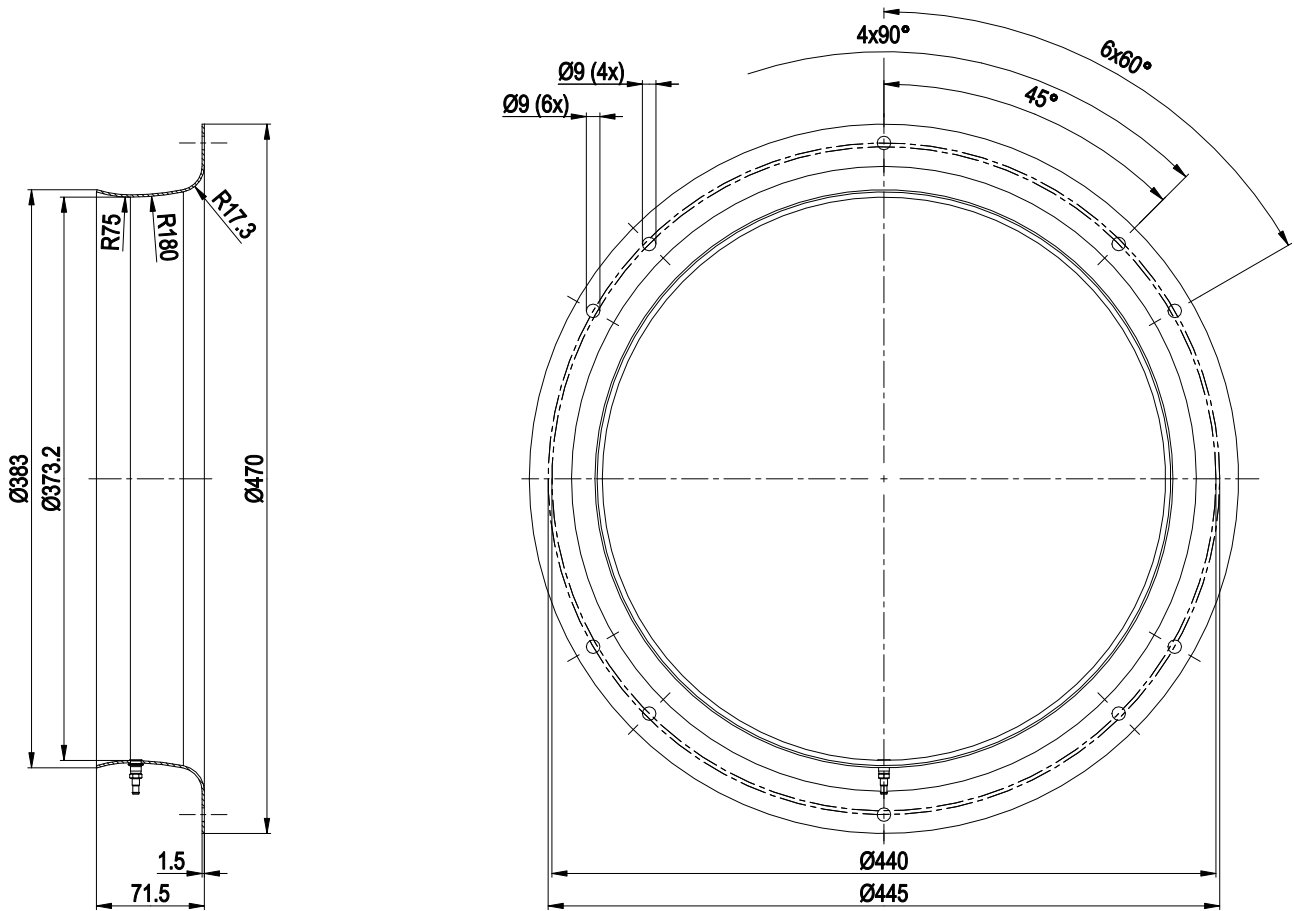

Inlet ring 50355-2-4013 with pressure tap (k-factor: 375)

Connection diagram

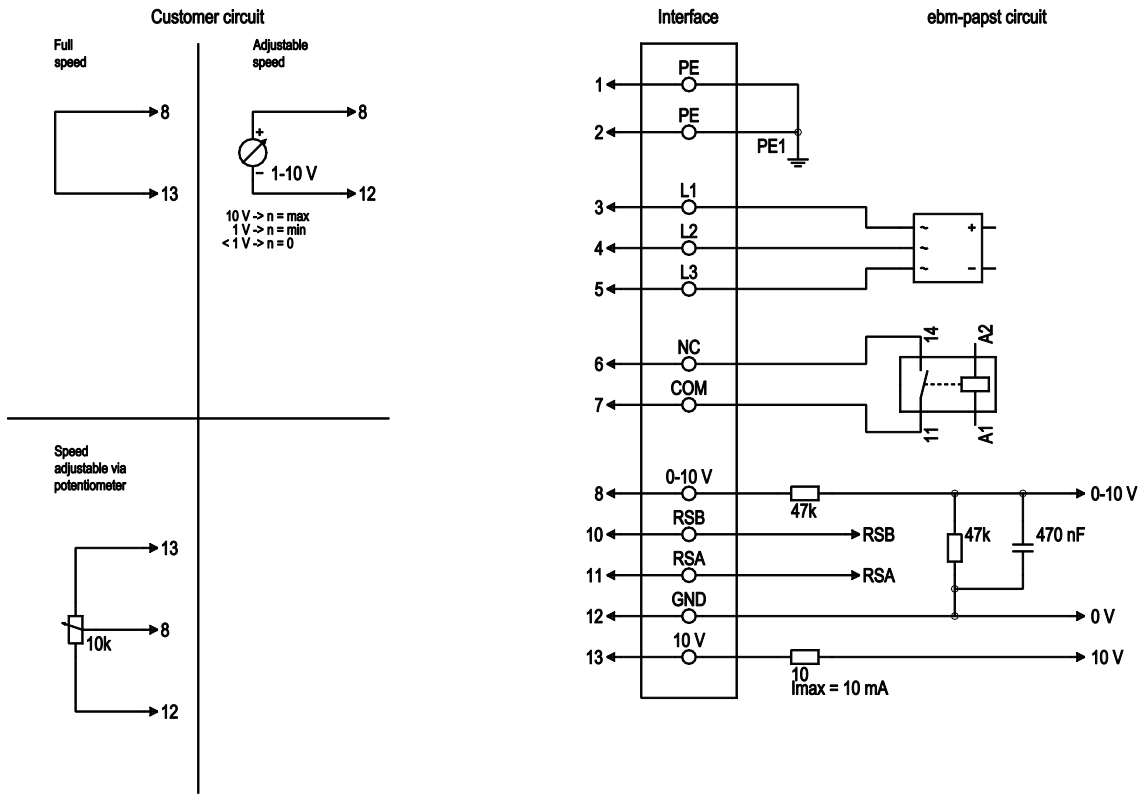

No.	Conn.	Designation	Color	Function/assignment
1	1, 2	PE	green/yellow	Protective earth
1	3	L1	black	Power supply
1	4	L2	black	Power supply
1	5	L3	black	Power supply
1	6	NC	white 1	Status relay, floating status contact, break for failure, contact rating 250 VAC / 2 A (AC1) / min. 10 mA; reinforced insulation on supply side and basic insulation on control interface side
1	7	COM	white 2	Status relay, floating status contact, break for failure, contact rating 250 VAC / 2 A (AC1) / min. 10 mA; reinforced insulation on supply side and basic insulation on control interface side
2	8	0-10V	yellow	Analog input (set value), 0-10 V, $R_i = 100\text{ k}\Omega$, adjustable curve, SELV
2	10	RSB	brown	RS485 interface for MODBUS, RSB; SELV
2	11	RSA	white	RS485 interface for MODBUS, RSA; SELV
2	12	GND	blue	Reference ground for control interface, SELV
2	13	+10V	red	Fixed voltage output 10 VDC, $+10\text{ V} \pm 3\%$, max. 10 mA, short-circuit-proof power supply for external devices (e.g. pot), SELV fixed voltage input 24 VDC for setting parameters via MODBUS without line voltage supply



Curves: Air performance 50 Hz

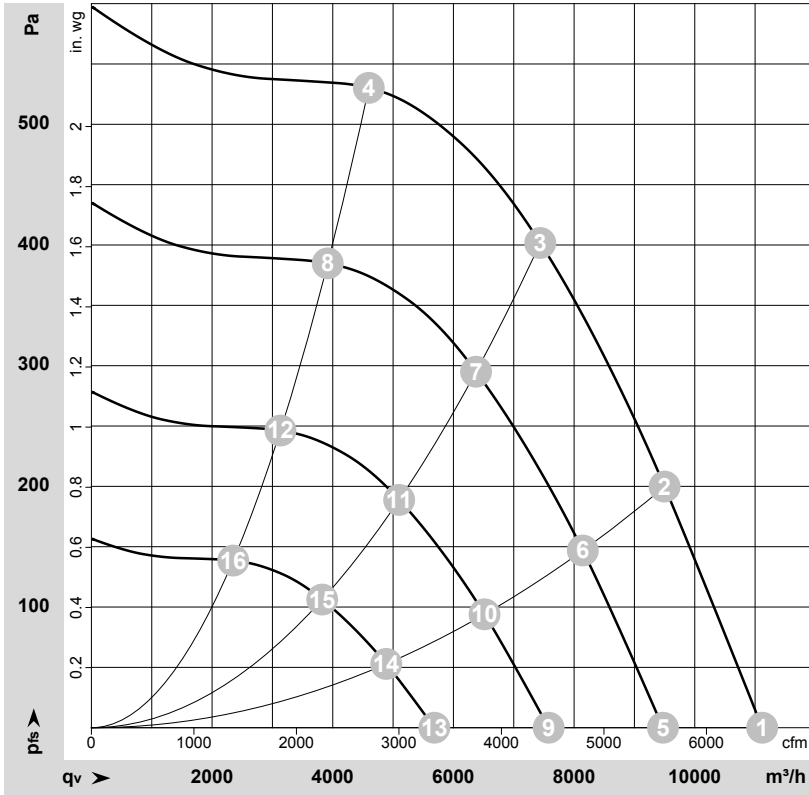

$\rho = 1.15 \text{ kg/m}^3 \pm 2 \%$

Measurement: LU-214301-1

Air performance measured according to ISO 5801 installation category A. For detailed information on the measurement setup, contact ebmpapst. Intake sound level: Sound power level according to ISO 13347 / sound pressure level measured at 1 m distance from fan axis. The values given are valid under the specified measuring conditions and may vary due to conditions of installation. For deviations from the standard configuration, the parameters have to be checked on the installed unit.

Measured values

	Wired	U	f	n	P _{ed}	I	LpA _{in}	LwA _{in}	LwA _{out}	q _v	p _{fs}	q _v	p _{fs}
		V	Hz	min ⁻¹	W	A	dB(A)	dB(A)	dB(A)	m ³ /h	Pa	cfm	in. wg
1	3~	400	50	1460	736	1.16	75	84	88	11120	0	6545	0.00
2	3~	400	50	1460	1052	1.62	75	80	85	9500	200	5590	0.80
3	3~	400	50	1460	1320	2.00	65	74	79	7440	400	4380	1.61
4	3~	400	50	1460	1204	1.85	69	77	81	4595	530	2705	2.13
5	3~	400	50	1250	455	0.71	71	80	84	9475	0	5575	0.00
6	3~	400	50	1250	663	1.02	71	77	81	8145	147	4795	0.59
7	3~	400	50	1250	799	1.23	62	70	76	6375	295	3750	1.18
8	3~	400	50	1250	744	1.14	65	73	76	3915	386	2305	1.55
9	3~	400	50	1000	233	0.37	66	74	78	7580	0	4460	0.00
10	3~	400	50	1000	340	0.52	65	71	75	6515	94	3835	0.38
11	3~	400	50	1000	409	0.63	56	64	70	5100	189	3000	0.76
12	3~	400	50	1000	381	0.58	59	67	71	3135	247	1845	0.99
13	3~	400	50	750	98	0.15	58	67	71	5685	0	3345	0.00
14	3~	400	50	750	143	0.22	58	64	68	4885	53	2875	0.21
15	3~	400	50	750	173	0.26	49	57	63	3825	106	2250	0.43
16	3~	400	50	750	161	0.25	52	60	64	2350	139	1385	0.56

Wired = Wiring · U = Voltage · f = Frequency · n = Speed (rpm) · P_{ed} = Power consumption · I = Current draw · LpA_{in} = Sound pressure level intake side · LwA_{in} = Sound power level intake side · LwA_{out} = Sound power level outlet side · q_v = Air flow · p_{fs} = Pressure increase

