



R3G500-AQ33-01 ebmpapst Datasheet
 sales@fansco.com
 www.fansco.com

Limited partnership · Headquarters Muldingen
 Amtsgericht (court of registration) Stuttgart · HRA 590344

General partner Elektrobau Muldingen GmbH · Headquarters Muldingen
 Amtsgericht (court of registration) Stuttgart · HRB 590142

Nominal data

Type	R3G500-AQ33-01	
Motor	M3G150-IF	
Phase		3~
Nominal voltage	VAC	400
Nominal voltage range	VAC	380 .. 480
Frequency	Hz	50/60
Method of obtaining data		ml
Speed (rpm)	min ⁻¹	2200
Power consumption	W	5500
Current draw	A	8.4
Min. ambient temperature	°C	-25
Max. ambient temperature	°C	45

ml = Max. load · me = Max. efficiency · fa = Free air · cs = Customer specification · ce = Customer equipment
 Subject to change

Data according to Commission Regulation (EU) 327/2011 (EN 17166)

		Actual	Req. 2015			
01 Overall efficiency η_{es}	%	64.5	59.3	09 Power consumption P_{ed}	kW	5.48
02 Measurement category		A		09 Air flow q_v	m ³ /h	9955
03 Efficiency category		Static		09 Pressure increase p_{fs}	Pa	1223
04 Efficiency grade N		67.2	62	10 Speed (rpm) n	min ⁻¹	2220
05 Variable speed drive		Yes		11 Specific ratio*		1.01

Data obtained at optimum efficiency level.

The ErP data is determined using a motor-impeller combination in a standardized measurement setup.

* Specific ratio = $1 + p_{fs} / 100\,000\text{ Pa}$

LU-128472



Technical description

Weight	33.3 kg
Size	500 mm
Motor size	150
Rotor surface	Painted black
Electronics housing material	Die-cast aluminum
Impeller material	Sheet aluminum
Number of blades	7
Direction of rotation	Clockwise, viewed toward rotor
Degree of protection	IP55
Insulation class	"F"
Moisture (F) / Environmental (H) protection class	H1
Max. permitted ambient temp. for motor (transport/storage)	+80 °C
Min. permitted ambient temp. for motor (transport/storage)	-40 °C
Installation position	Shaft horizontal or rotor on bottom; rotor on top on request
Condensation drainage holes	On rotor side
Mode	S1
Motor bearing	Ball bearing
Technical features	<ul style="list-style-type: none"> - Output 10 VDC, max. 10 mA - Output 20 VDC, max. 50 mA - Output for slave 0-10 V - Input for sensor 0-10 V or 4-20 mA - External 24 V input (parameter setting) - External release input - Alarm relay - Integrated PID controller - Motor current limitation - PFC, passive - RS-485 MODBUS-RTU - Soft start - EEPROM write cycles: 100,000 maximum - Control input 0-10 VDC / PWM - Control interface with SELV potential safely disconnected from the mains - Thermal overload protection for electronics/motor - Line undervoltage / phase failure detection
EMC immunity to interference	According to EN 61000-6-2 (industrial environment)
EMC interference emission	According to EN 61000-6-3 (household environment), except EN 61000-3-2 for professionally used equipment with a total rated power greater than 1 kW
Touch current according to IEC 60990 (measuring circuit Fig. 4, TN system)	<= 3.5 mA
Electrical hookup	Terminal box
Motor protection	Reverse polarity and locked-rotor protection
Protection class	I (with customer connection of protective earth)
Conformity with standards	EN 61800-5-1; CE
Approval	CSA C22.2 No. 77 + CAN/CSA-E60730-1; EAC; UL 1004-7 + 60730-1

EC centrifugal fan - RadiPac

backward-curved, single-intake

Comment

Maximum permissible operating altitude 4000 m above sea level according to DIN 61800-5-1_2008_Sec. 4.3.6.4.1 overvoltage category II.
Up to 2000 m above sea level, overvoltage category III applies.



Product drawing

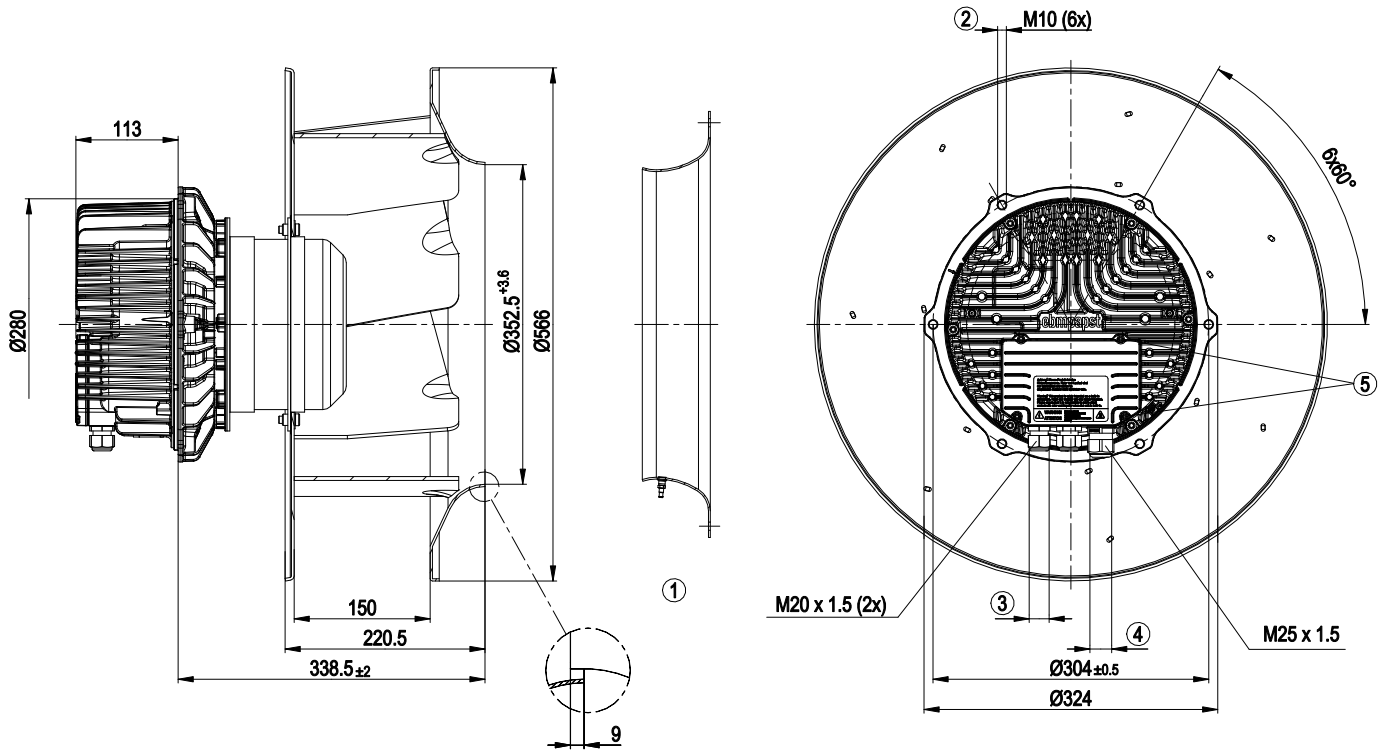

1	Accessory part: inlet ring 64025-2-4013 not included in scope of delivery, other inlet rings on request
2	Max. clearance for screw 20 mm
3	Cable diameter min. 4 mm, max. 10 mm, tightening torque 4 ± 0.6 Nm
4	Cable diameter min. 9 mm, max. 16 mm, tightening torque 6 ± 0.9 Nm
5	Tightening torque 3.5 ± 0.5 Nm



Accessory part

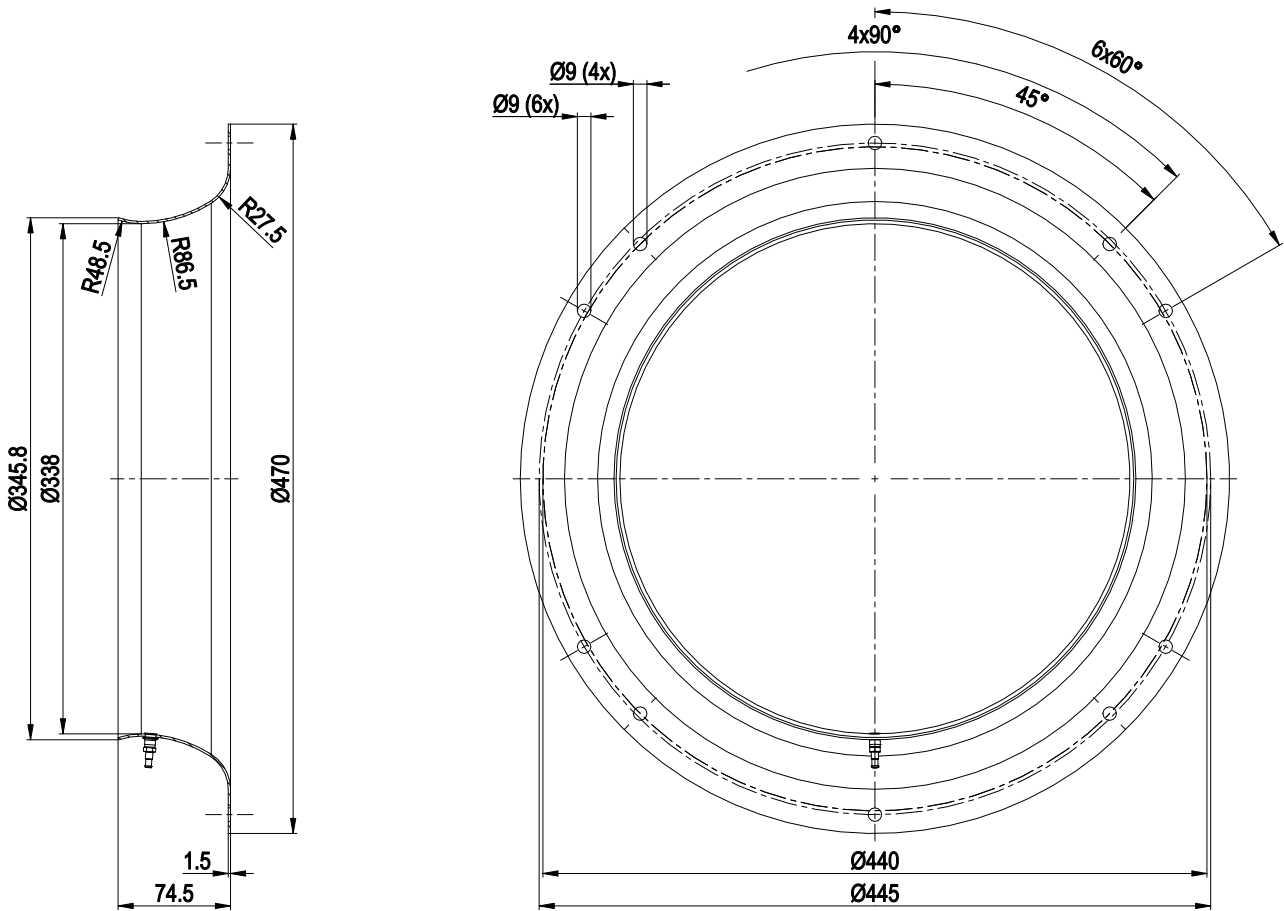

Inlet ring 64025-2-4013 with pressure tap (k-factor: 281)

Connection diagram

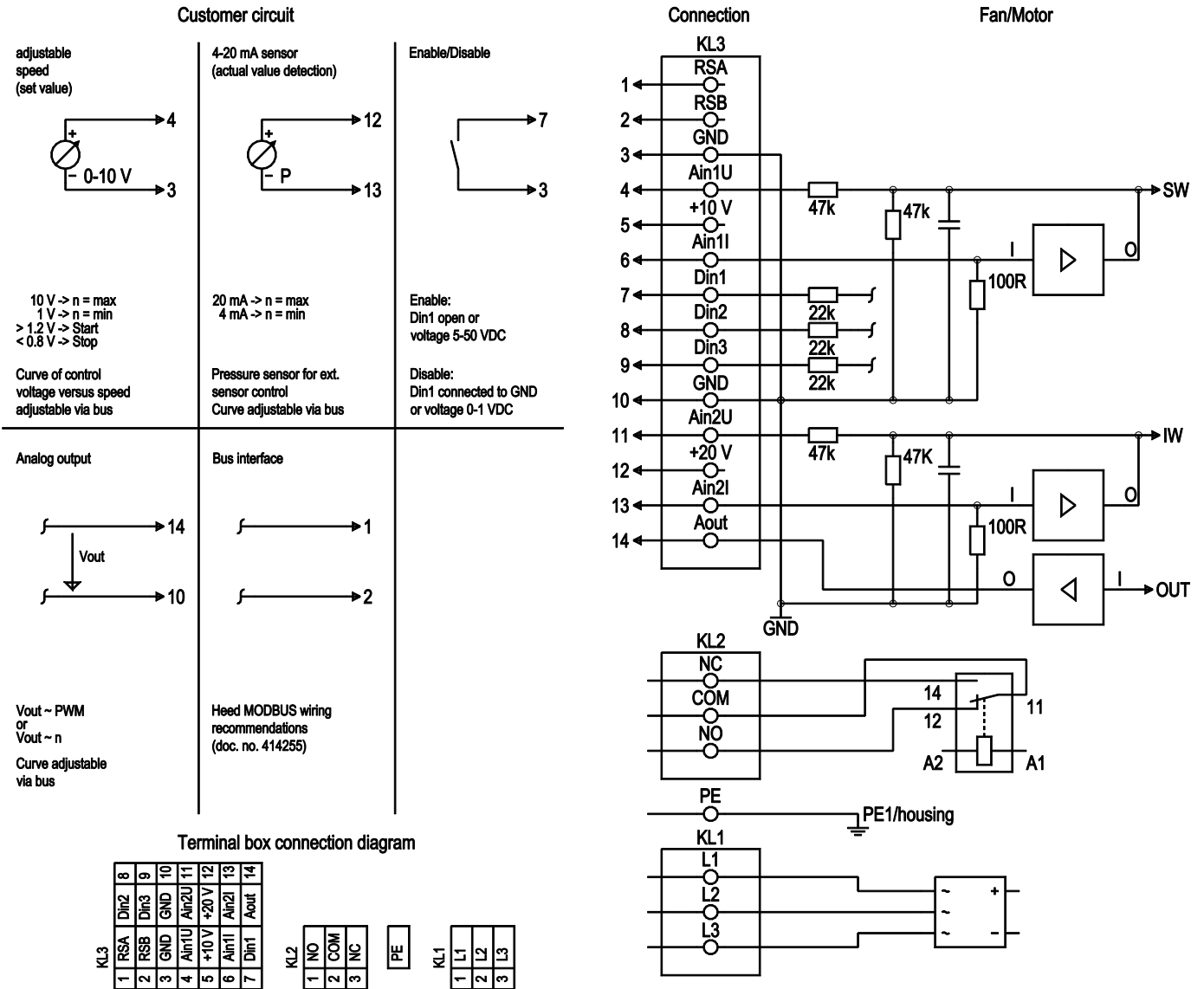

No.	Conn.	Designation	Function/assignment
KL 1	1	L1	Supply connection, power supply, phase, see nameplate for voltage range
KL 1	2	L2	Supply connection, power supply, phase, see nameplate for voltage range
KL 1	3	L3	Supply connection, power supply, phase, see nameplate for voltage range
PE		PE	Ground connection, PE connection
KL 2	1	NO	Status relay, floating status contact, make for failure
KL 2	2	COM	Status relay, floating status contact, changeover contact, common connection, contact rating, max. 250 VAC/2 A (AC1)/min. 10 mA
KL 2	3	NC	Status relay, floating status contact, break for failure
KL 3	1	RSA	Bus connection RS485, RSA, MODBUS RTU; SELV
KL 3	2	RSB	Bus connection RS485, RSB, MODBUS RTU; SELV
KL 3	3 / 10	GND	Reference ground for control interface, SELV
KL 3	4	Ain1 U	Analog input 1, set value: 0-10 V, Ri = 100 kΩ, adjustable curve, only usable as alternative to input Ain1 I; SELV



No.	Conn.	Designation	Function/assignment
KL 3	5	+ 10 V	Fixed voltage output 10 VDC, +10 V \pm 3%, max. 10 mA, short-circuit-proof, power supply for external devices (e.g. pot); SELV
KL 3	6	Ain1 I	Analog input 1, set value: 4-20 mA, Ri = 100 Ω , adjustable curve, only usable as alternative to input Ain1 U; SELV
KL 3	7	Din1	Digital input 1: enable electronics, enable: pin open or applied voltage 5-50 VDC disable: bridge to GND or applied voltage < 1 VDC reset function: triggers software reset after a level change to < 1 VDC; SELV
KL 3	8	Din2	Digital input 2: Switching parameter sets 1/2, according to EEPROM setting, the valid or used parameter set can be selected via bus or via digital input DIN2. Parameter set 1: pin open or applied voltage 5-50 VDC Parameter set 2: bridge to GND or applied voltage < 1 VDC; SELV
KL 3	9	Din3	Digital input 3: Direction of action of integrated controller, according to EEPROM setting, the direction of action of the integrated controller can be selected as normal/inverse via bus or digital input Normal: Pin open or applied voltage 5-50 VDC Inverse: Bridge to GND or applied voltage < 1 VDC; SELV
KL 3	11	Ain2 U	Analog input 2, measured value: 0-10 V, Ri = 100 k Ω , adjustable curve, only usable as alternative to input Ain2 I; SELV
KL 3	12	+ 20 V	Fixed voltage output 20 VDC, +20 V +25/-10%, max. 50 mA, short-circuit-proof, power supply for external devices (e.g. sensors); SELV Alternatively: +24 VDC input for parameterization without line voltage
KL 3	13	Ain2 I	Analog input 2, measured value: 4-20 mA, Ri = 100 Ω , adjustable curve, only usable as alternative to input Ain2 U; SELV
KL 3	14	Aout	Analog output 0-10 V, max. 5 mA, output of current motor modulation level; adjustable curve; SELV

Curves: Air performance 50 Hz

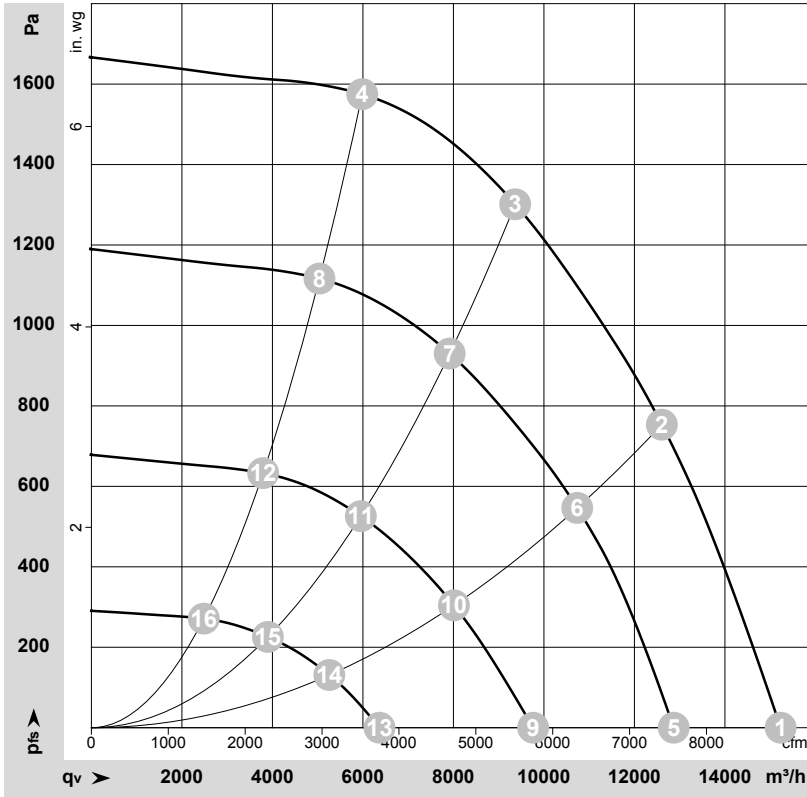

$\rho = 1.15 \text{ kg/m}^3 \pm 2 \%$

Measurement: LU-153974-1

Air performance measured according to ISO 5801 installation category A. For detailed information on the measurement setup, contact ebmpapst. Intake sound level: Sound power level according to ISO 13347 / sound pressure level measured at 1 m distance from fan axis. The values given are valid under the specified measuring conditions and may vary due to conditions of installation. For deviations from the standard configuration, the parameters have to be checked on the installed unit.

Measured values

	Wired	U	f	n	P _{ed}	I	LpA _{in}	LwA _{in}	LwA _{out}	q _v	P _{fs}	q _v	P _{fs}
		V	Hz	min ⁻¹	W	A	dB(A)	dB(A)	dB(A)	m ³ /h	Pa	cfm	in. wg
1	3~	400	50	2200	3660	5.78	90	98	104	15230	0	8965	0.00
2	3~	400	50	2200	4992	7.77	82	90	97	12605	750	7420	3.01
3	3~	400	50	2200	5500	8.40	80	88	95	9365	1300	5510	5.22
4	3~	400	50	2200	5067	7.82	83	90	97	5985	1575	3525	6.32
5	3~	400	50	1865	2200	3.60	85	93	99	12870	0	7575	0.00
6	3~	400	50	1865	3035	4.80	78	85	93	10735	552	6320	2.22
7	3~	400	50	1865	3413	5.36	76	83	93	7920	934	4660	3.75
8	3~	400	50	1865	3044	4.81	78	85	93	5040	1117	2965	4.48
9	3~	400	50	1405	1023	1.96	77	85	90	9760	0	5745	0.00
10	3~	400	50	1405	1361	2.46	70	77	84	8010	308	4715	1.24
11	3~	400	50	1405	1530	2.69	69	77	84	5955	528	3505	2.12
12	3~	400	50	1405	1372	2.49	71	78	84	3795	633	2235	2.54
13	3~	400	50	925	337	0.81	66	74	80	6365	0	3745	0.00
14	3~	400	50	925	435	0.97	59	67	72	5260	132	3095	0.53
15	3~	400	50	925	483	1.05	59	67	73	3900	227	2295	0.91
16	3~	400	50	925	439	0.97	59	67	73	2485	271	1460	1.09

Wired = Wiring · U = Voltage · f = Frequency · n = Speed (rpm) · P_{ed} = Power consumption · I = Current draw · LpA_{in} = Sound pressure level intake side · LwA_{in} = Sound power level intake side · LwA_{out} = Sound power level outlet side · q_v = Air flow · P_{fs} = Pressure increase

