

R3G450-RK56-07 ebmpapst Datasheet

sales@fansco.com

www.fansco.com

Nominal data

Type	R3G450-RK56-07	
Motor	M3G112-GA	
Phase		3~
Nominal voltage	VAC	400
Nominal voltage range	VAC	380 .. 480
Frequency	Hz	50/60
Method of obtaining data		ml
Speed (rpm)	min ⁻¹	1545
Power consumption	W	950
Current draw	A	1.5
Min. ambient temperature	°C	-25
Max. ambient temperature	°C	60

ml = Max. load · me = Max. efficiency · fa = Free air · cs = Customer specification · ce = Customer equipment
Subject to change

Data according to Commission Regulation (EU) 327/2011 (EN 17166)

		Actual	Req. 2015			
01 Overall efficiency η_{es}	%	64.8	51.2	09 Power consumption P_{ed}	kW	0.92
02 Measurement category		A		09 Air flow q_v	m ³ /h	4420
03 Efficiency category		Static		09 Pressure increase p_{fs}	Pa	450
04 Efficiency grade N		75.6	62	10 Speed (rpm) n	min ⁻¹	1545
05 Variable speed drive		Yes		11 Specific ratio*		1.00

Data obtained at optimum efficiency level.

The ErP data is determined using a motor-impeller combination in a standardized measurement setup.

* Specific ratio = $1 + p_{fs} / 100\,000\text{ Pa}$

LU-186335



Technical description

Weight	10.65 kg
Size	450 mm
Motor size	112
Rotor surface	Painted black
Electronics housing material	Die-cast aluminum
Impeller material	PP plastic
Number of blades	6
Direction of rotation	Clockwise, viewed toward rotor
Degree of protection	IP55
Insulation class	"F"
Moisture (F) / Environmental (H) protection class	H1
Ambient temperature note	Occasional start-up at temperatures between -40°C and -25°C is permitted. For continuous operation at ambient temperatures below -25°C (such as refrigeration applications), use must be made of a fan design with special low-temperature bearings.
Max. permitted ambient temp. for motor (transport/storage)	+80 °C
Min. permitted ambient temp. for motor (transport/storage)	-40 °C
Installation position	Shaft horizontal or rotor on bottom; rotor on top on request
Condensation drainage holes	On rotor side
Mode	S1
Motor bearing	Ball bearing
Technical features	<ul style="list-style-type: none"> - Output 10 VDC, max. 10 mA - Operation and alarm display - External 24 V input (parameter setting) - Alarm relay - Integrated PID controller - Motor current limitation - PFC, passive - RS-485 MODBUS-RTU - Soft start - EEPROM write cycles: 100,000 maximum - Control input 0-10 VDC / PWM - Control interface with SELV potential safely disconnected from the mains - Thermal overload protection for electronics/motor - Line undervoltage / phase failure detection
EMC immunity to interference	According to EN 61000-6-2 (industrial environment)
EMC circuit feedback	According to EN 61000-3-2/3
EMC interference emission	According to EN 61000-6-3 (household environment)
Touch current according to IEC 60990 (measuring circuit Fig. 4, TN system)	<= 3.5 mA
Motor protection	Thermal overload protector (TOP) internally connected
With cable	Variable
Protection class	I (with customer connection of protective earth)
Conformity with standards	EN 61800-5-1; EN 60335-1; CE
Approval	UL 1004-7 + 60730-1; EAC; CSA C22.2 No. 77 + CAN/CSA-E60730-1



Product drawing

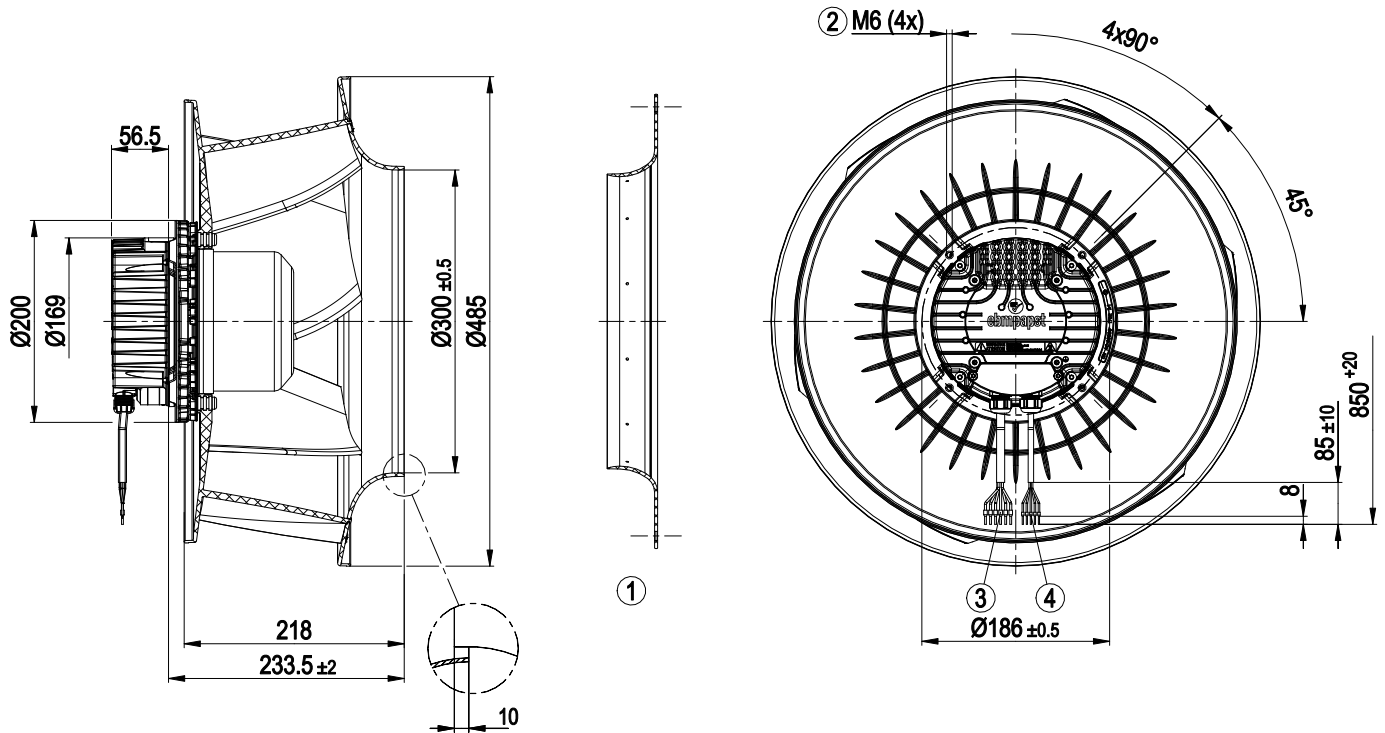

1	Accessory part: inlet ring 45901-2-2943 not included in scope of delivery
2	Max. clearance for screw 16 mm
3	Cable PVC AWG18, 6x crimped ferrules
4	Cable PVC AWG22, 5x crimped ferrules



Accessory part

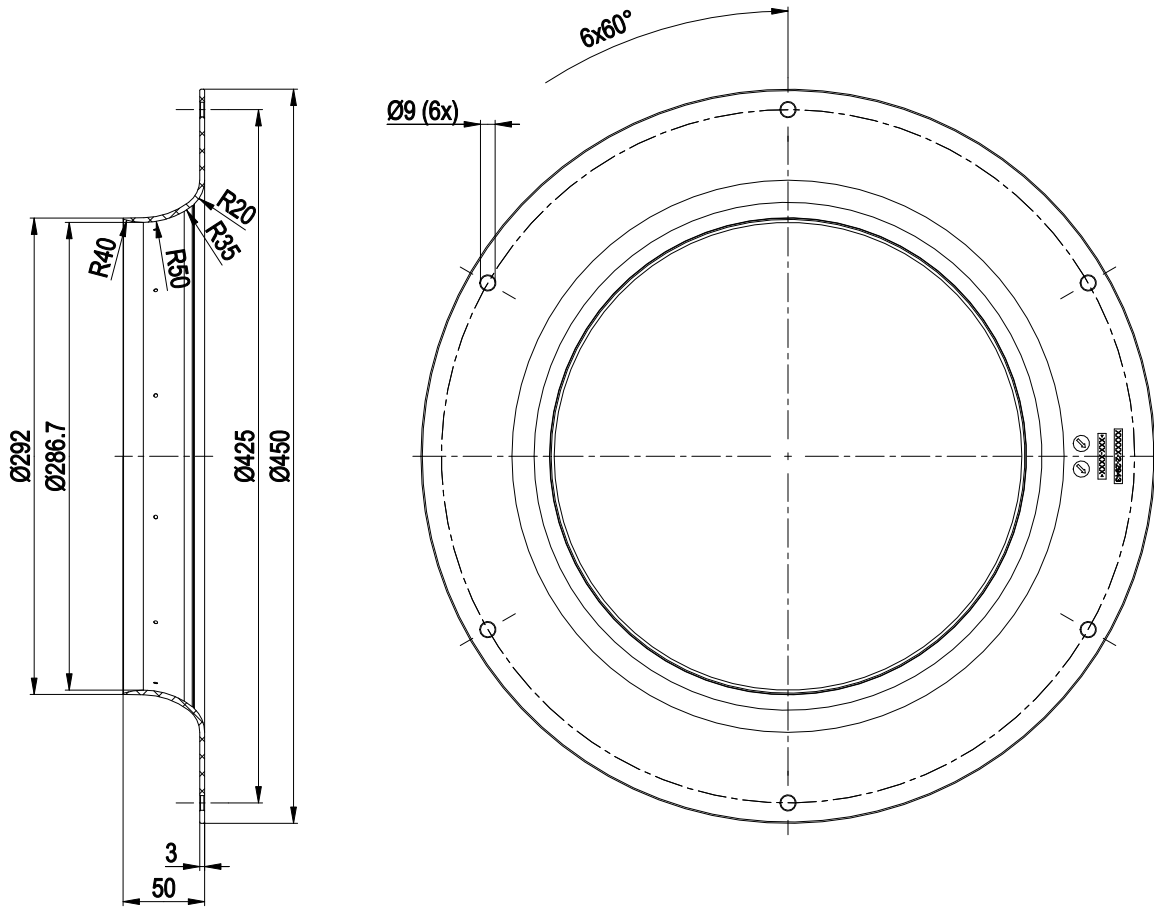

Inlet ring 45901-2-2943 not included in scope of delivery



Connection diagram

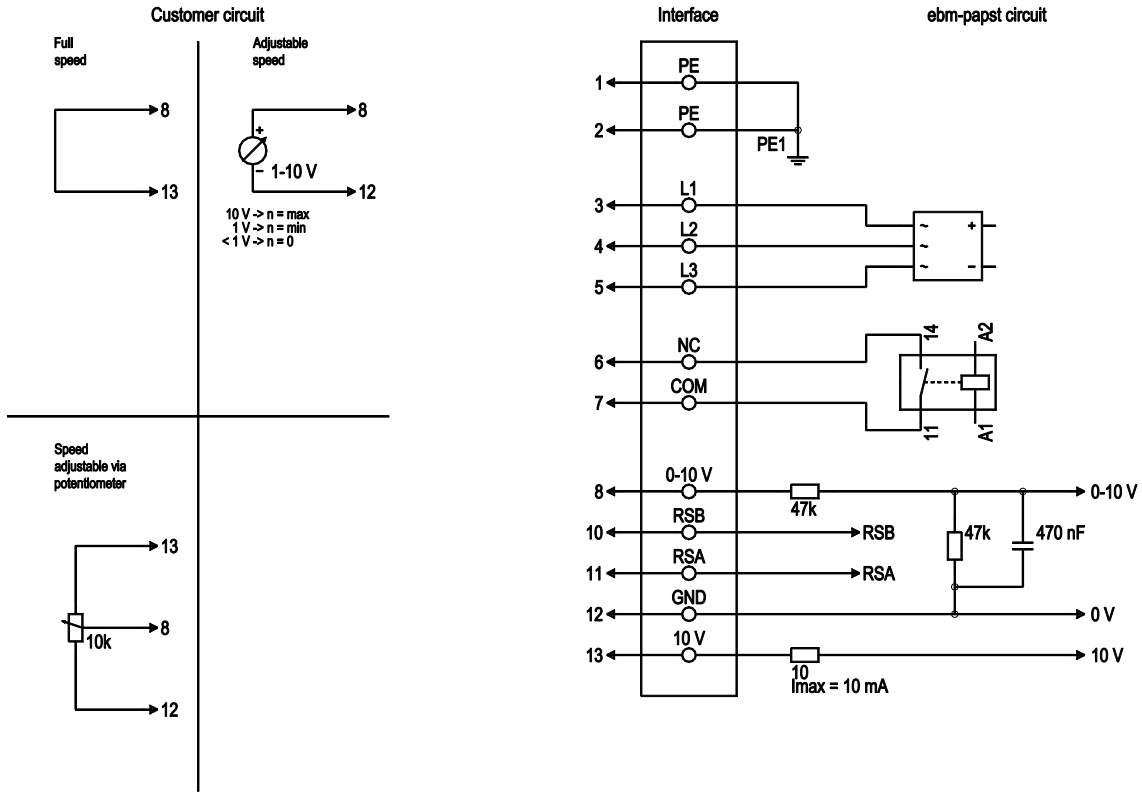

No.	Conn.	Designation	Color	Function/assignment
1	1, 2	PE	green/yellow	Protective earth
1	3	L1	black	Power supply
1	4	L2	black	Power supply
1	5	L3	black	Power supply
1	6	NC	white 1	Status relay, floating status contact, break for failure, contact rating 250 VAC / 2 A (AC1) / min. 10 mA; reinforced insulation on supply side and basic insulation on control interface side
1	7	COM	white 2	Status relay, floating status contact, break for failure, contact rating 250 VAC / 2 A (AC1) / min. 10 mA; reinforced insulation on supply side and basic insulation on control interface side
2	8	0-10V	yellow	Analog input (set value), 0-10 V, $R_i = 100\text{ k}\Omega$, adjustable curve, SELV
2	10	RSB	brown	RS485 interface for MODBUS, RSB; SELV
2	11	RSA	white	RS485 interface for MODBUS, RSA; SELV
2	12	GND	blue	Reference ground for control interface, SELV
2	13	+10V	red	Fixed voltage output 10 VDC, $+10\text{ V} \pm 3\%$, max. 10 mA, short-circuit-proof power supply for external devices (e.g. pot), SELV fixed voltage input 24 VDC for setting parameters via MODBUS without line voltage supply



Curves: Air performance 50 Hz

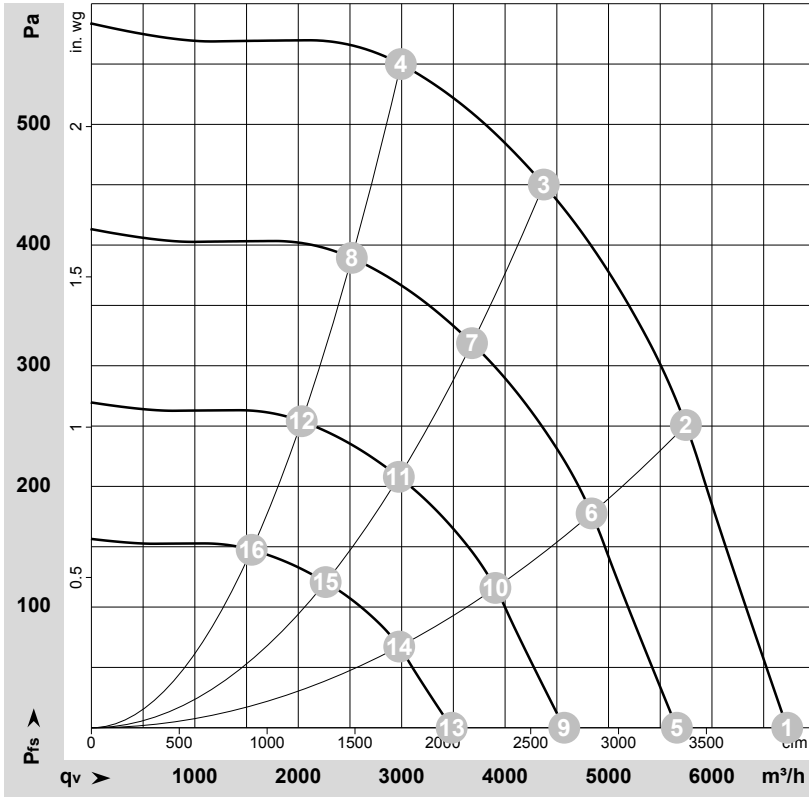

$\rho = 1.15 \text{ kg/m}^3 \pm 2 \%$

Measurement: LU-186335-1

Air performance measured according to ISO 5801 installation category A. For detailed information on the measurement setup, contact ebmpapst. Intake sound level: Sound power level according to ISO 13347 / sound pressure level measured at 1 m distance from fan axis. The values given are valid under the specified measuring conditions and may vary due to conditions of installation. For deviations from the standard configuration, the parameters have to be checked on the installed unit.

Measured values

	Wired	U	f	n	P _{ed}	I	LpA _{in}	LwA _{in}	LwA _{out}	q _v	P _{fs}	q _v	P _{fs}
		V	Hz	min ⁻¹	W	A	dB(A)	dB(A)	dB(A)	m ³ /h	Pa	cfm	in. wg
1	3~	400	50	1545	580	0.96	71	79	86	6730	0	3960	0.00
2	3~	400	50	1545	822	1.33	69	78	84	5750	250	3385	1.00
3	3~	400	50	1545	950	1.50	65	73	80	4375	450	2575	1.81
4	3~	400	50	1545	840	1.36	67	75	81	2990	550	1760	2.21
5	3~	400	50	1300	346	0.57	66	75	82	5660	0	3330	0.00
6	3~	400	50	1300	489	0.79	65	73	80	4835	180	2845	0.72
7	3~	400	50	1300	551	0.89	61	69	76	3680	321	2165	1.29
8	3~	400	50	1300	500	0.81	63	71	77	2520	390	1480	1.57
9	3~	400	50	1050	182	0.30	61	69	76	4570	0	2690	0.00
10	3~	400	50	1050	258	0.42	60	68	75	3905	118	2300	0.47
11	3~	400	50	1050	290	0.47	56	64	70	2975	209	1750	0.84
12	3~	400	50	1050	264	0.43	57	66	72	2035	254	1195	1.02
13	3~	400	50	800	81	0.13	54	63	69	3485	0	2050	0.00
14	3~	400	50	800	114	0.18	53	61	68	2975	68	1750	0.27
15	3~	400	50	800	128	0.21	49	57	64	2265	121	1335	0.49
16	3~	400	50	800	117	0.19	50	59	65	1550	148	910	0.59

Wired = Wiring · U = Voltage · f = Frequency · n = Speed (rpm) · P_{ed} = Power consumption · I = Current draw · LpA_{in} = Sound pressure level intake side · LwA_{in} = Sound power level intake side · LwA_{out} = Sound power level outlet side · q_v = Air flow · P_{fs} = Pressure increase

