

R3G450-AL34-61

EC centrifugal fan

backward-curved, single-intake



R3G450-AL34-61 ebmpapst Datasheet

sales@fansco.com

www.fansco.com

Limited partnership · Headquarters Mulfingen
Amtsgericht (court of registration) Stuttgart · HRA 590344

General partner Elektrobau Mulfingen GmbH · Headquarters Mulfingen
Amtsgericht (court of registration) Stuttgart · HRB 590142

Nominal data

Type	R3G450-AL34-61	
Motor	M3G084-FA	
Phase		1~
Nominal voltage	VAC	230
Nominal voltage range	VAC	200 .. 277
Frequency	Hz	50/60
Method of obtaining data		ml
Speed (rpm)	min ⁻¹	1050
Power consumption	W	330
Current draw	A	1.4
Min. ambient temperature	°C	-25
Max. ambient temperature	°C	40

ml = Max. load · me = Max. efficiency · fa = Free air · cs = Customer specification · ce = Customer equipment
Subject to change

Data according to ErP Directive

		Actual	Req. 2015			
01 Overall efficiency η_{es}	%	60.2	46.2	09 Power consumption P_{ed}	kW	0.31
02 Measurement category		A		09 Air flow q_v	m ³ /h	2855
03 Efficiency category		Static		09 Pressure increase p_{fs}	Pa	216
04 Efficiency grade N		76	62	10 Speed (rpm) n	min ⁻¹	1055
05 Variable speed drive		Yes		11 Specific ratio*		1.00

Data obtained at optimum efficiency level.
The ErP data is determined using a motor-impeller combination in a standardized measurement setup.

* Specific ratio = $1 + p_{fs} / 100\,000\text{ Pa}$

LU-124818



Technical description

Weight	6.5 kg
Fan size	450 mm
Rotor surface	Painted black
Electronics housing material	Die-cast aluminum
Impeller material	PP plastic
Number of blades	6
Direction of rotation	Clockwise, viewed toward rotor
Degree of protection	IP20
Insulation class	"B"
Moisture (F) / Environmental (H) protection class	F0
Max. permitted ambient temp. for motor (transport/storage)	+80 °C
Min. permitted ambient temp. for motor (transport/storage)	-40 °C
Installation position	Shaft horizontal or rotor on top; rotor on bottom on request
Condensation drainage holes	None
Mode	S1
Motor bearing	Ball bearing
Technical features	<ul style="list-style-type: none"> - Operation and alarm display: reversible voltage output 0 V / +15 V - Integrated PID controller - Motor current limitation - PFC, active - RS-485 ebmBUS - Soft start - Control interface with SELV potential safely disconnected from supply - Thermal overload protection for electronics/motor - Line undervoltage / phase failure detection
EMC immunity to interference	According to EN 61000-6-2 (industrial environment)
EMC circuit feedback	According to EN 61000-3-2/3
EMC interference emission	According to EN 61000-6-4 (industrial environment)
Touch current according to IEC 60990 (measuring circuit Fig. 4, TN system)	<= 3.5 mA
Electrical hookup	With plug
Motor protection	Thermal overload protector (TOP) internally connected
With cable	Variable
Protection class	I (with customer connection of protective earth)
Conformity with standards	EN 61800-5-1; CE
Approval	C22.2 No.77 + CAN/CSA-E60730-1; UL1004-3 +60730; EAC

Product drawing

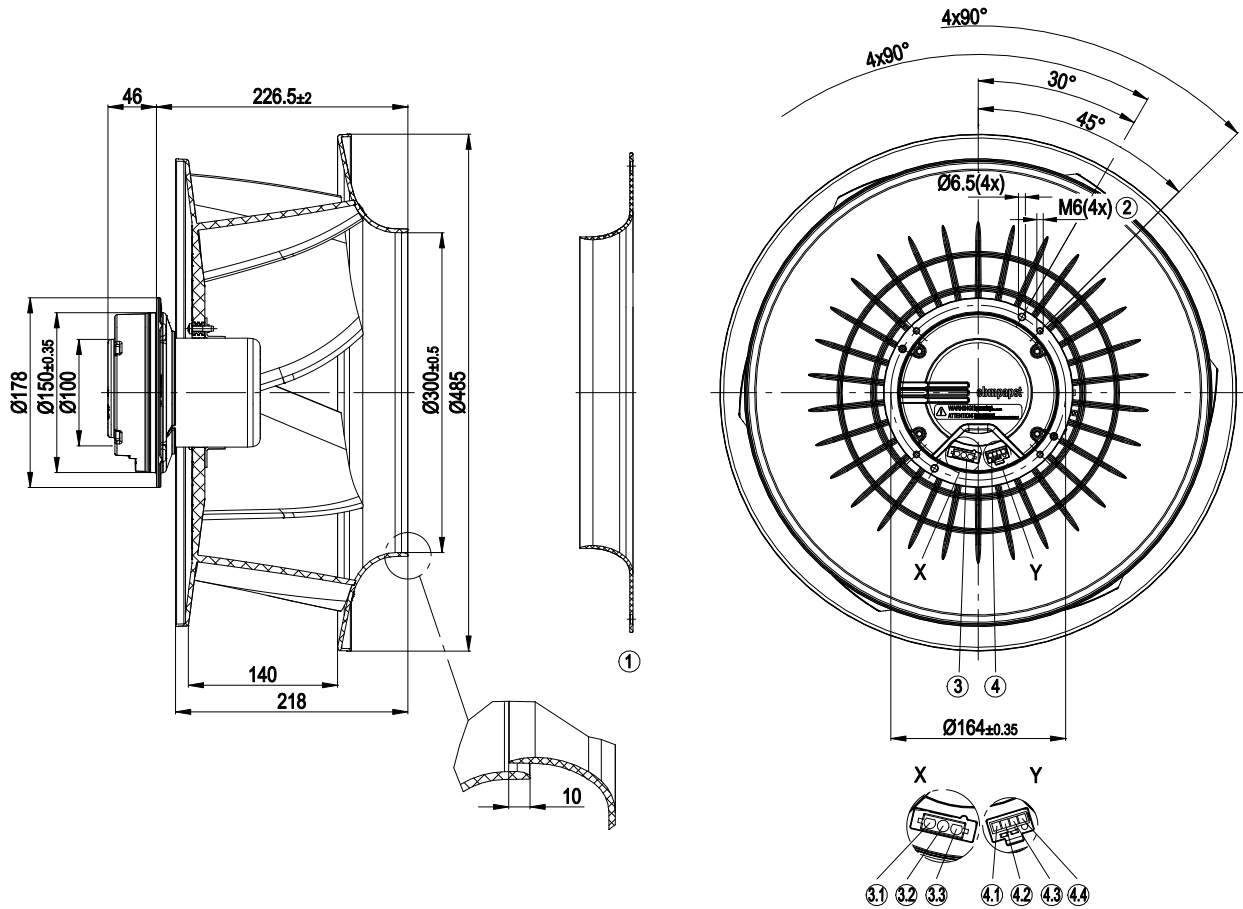

1	Accessory part: inlet ring 45901-2-2943 not included in scope of delivery
2	Max. clearance for screw 10 mm
3	Header Lonco no. C63502-3A, mating connectors with sockets not included in scope of delivery
3.1	PE
3.2	N
3.3	L
4	4-pole header Molex 39-30-2040, mating connector with sockets not included in scope of delivery
4.1	RSB
4.2	RSA
4.3	+15 V; in case of fault: 0 V
4.4	0 V; in case of fault: +15 V



Accessory part

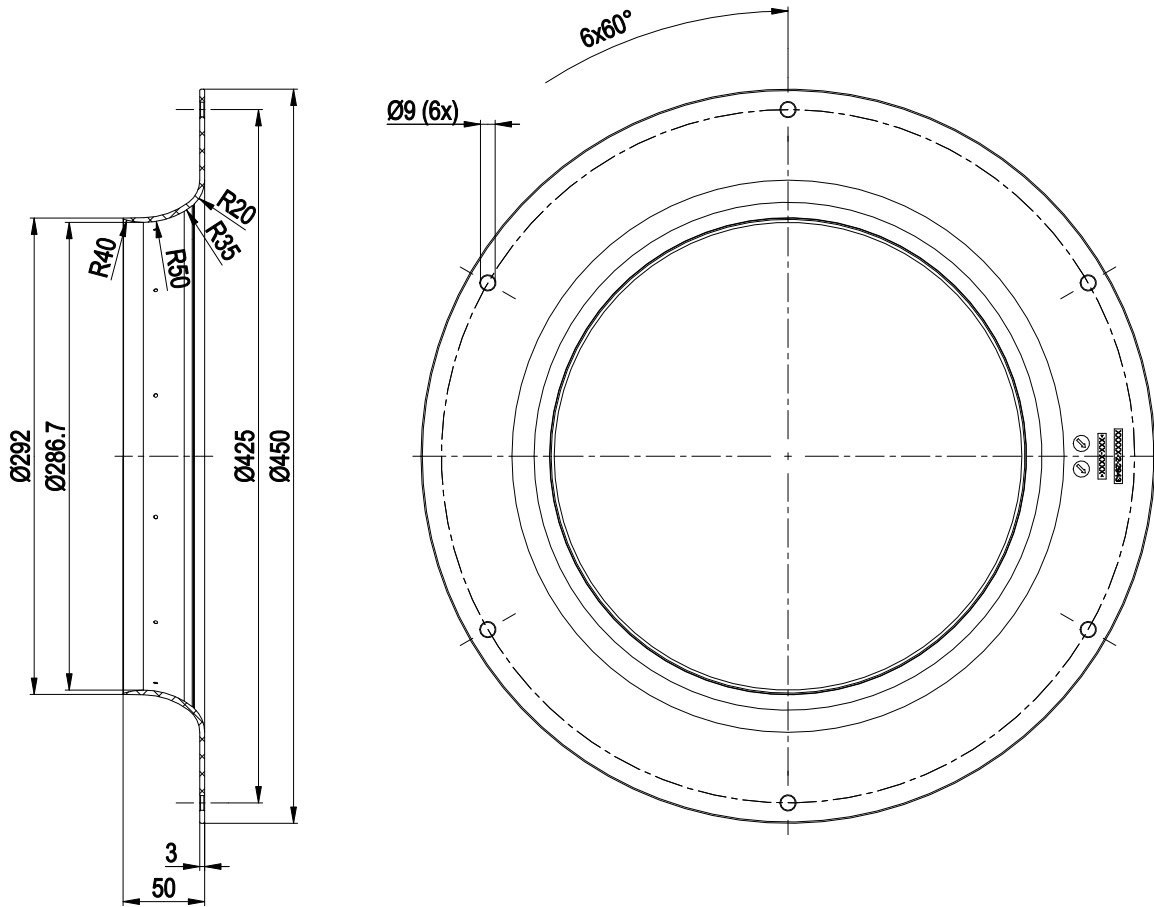

Inlet ring 45901-2-2943 not included in scope of delivery

EC centrifugal fan

backward-curved, single-intake

Connection diagram

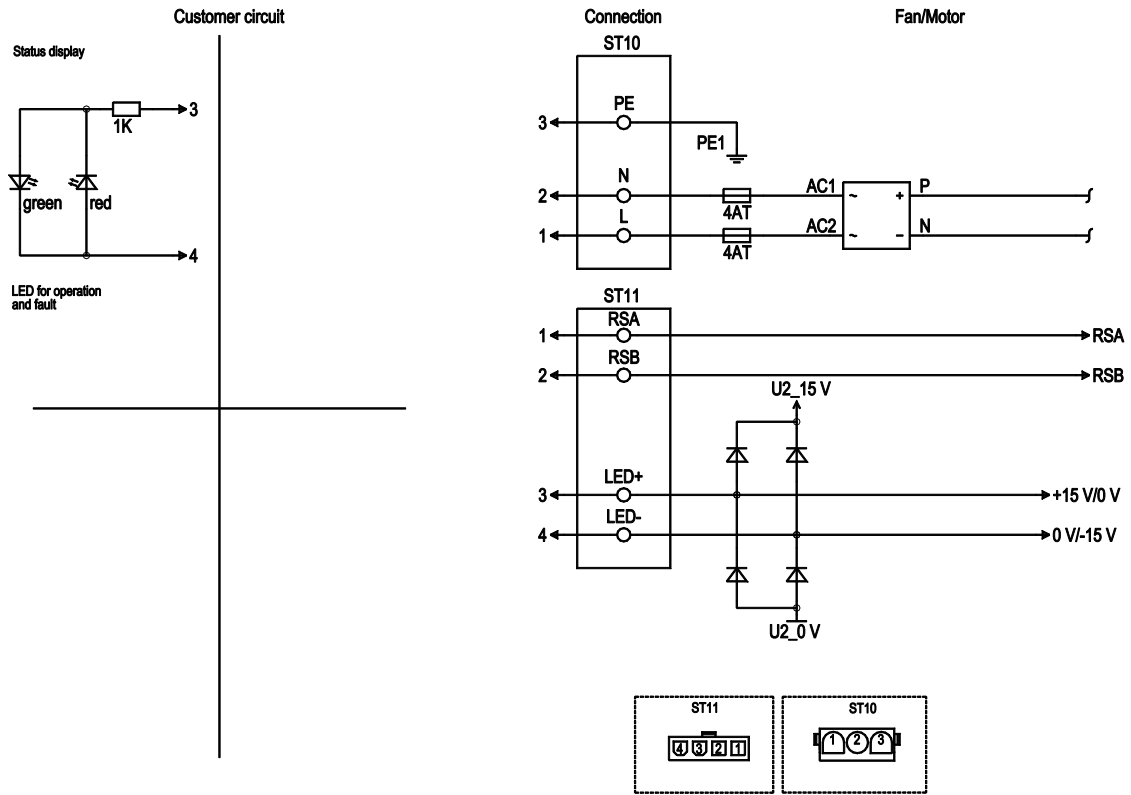

No.	Conn.	Designation	Color	Function/assignment
10	1	L		Power supply, phase, 50/60 Hz
10	2	N		Power supply, neutral conductor, 50/60 Hz
10	3	PE		Protective earth
11	1	RSA		RS485 interface for ebmBUS, RSA, SELV
11	2	RSB		RS485 interface for ebmBUS, RSB, SELV
11	3	LED +		Voltage output 15 V (+15%/-10%), max. 30 mA, power supply for external devices (e.g. status display for LED), SELV
11	4	LED -		Reference ground for control interface, SELV



Curves: Air performance 50 Hz

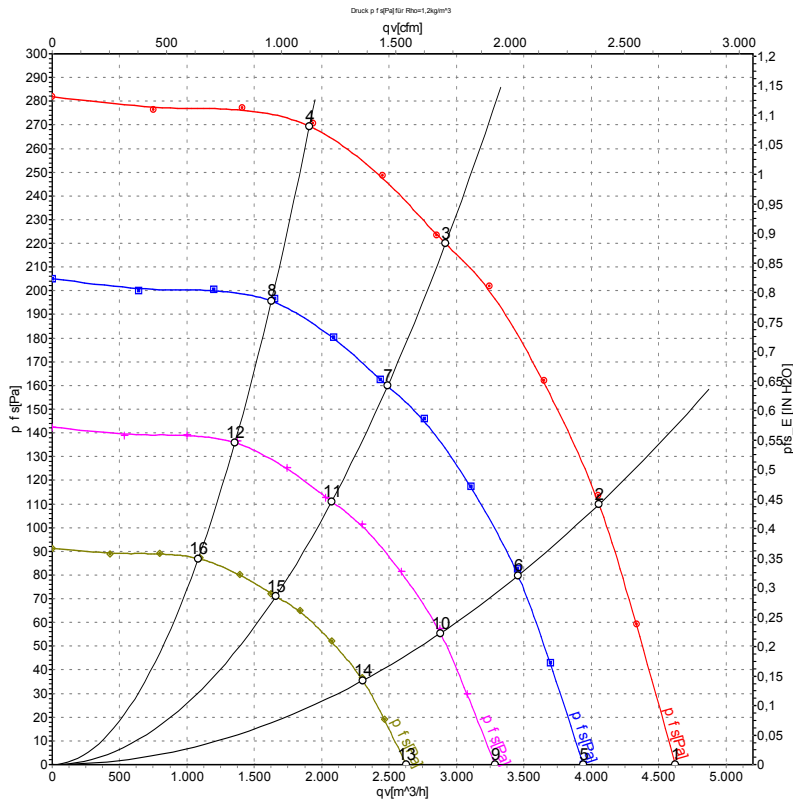

Measurement: LU-124818-1

Air performance measured according to ISO 5801 installation category A. For detailed information on the measurement setup, contact ebmpapst. Intake sound level: Sound power level according to ISO 13347 / sound pressure level measured at 1 m distance from fan axis. The values given are valid under the specified measuring conditions and may vary due to conditions of installation. For deviations from the standard configuration, the parameters have to be checked on the installed unit.

Measured values

	U	f	n	P _{ed}	I	LpA _{in}	LwA _{in}	LwA _{out}	q _v	P _{fs}	q _v	P _{fs}
	V	Hz	min ⁻¹	W	A	dB(A)	dB(A)	dB(A)	m ³ /h	Pa	cfm	inH ₂ O
1	230	50	1050	196	0.86	71	77	80	4625	0	2720	0.00
2	230	50	1050	283	1.24	60	68	75	4055	110	2390	0.44
3	230	50	1050	330	1.40	53	61	68	2920	220	1720	0.88
4	230	50	1050	302	1.32	58	66	72	1910	270	1125	1.08
5	230	50	900	121	0.53	67	73	76	3940	0	2320	0.00
6	230	50	900	175	0.77	56	64	72	3455	82	2035	0.33
7	230	50	900	199	0.87	50	58	65	2490	160	1465	0.64
8	230	50	900	187	0.82	54	63	69	1625	197	955	0.79
9	230	50	750	70	0.31	63	69	72	3285	0	1935	0.00
10	230	50	750	101	0.44	52	60	68	2880	57	1695	0.23
11	230	50	750	115	0.50	46	54	61	2075	111	1220	0.45
12	230	50	750	108	0.47	50	59	65	1355	137	800	0.55
13	230	50	600	36	0.16	58	65	67	2630	0	1545	0.00
14	230	50	600	52	0.23	47	55	63	2305	36	1355	0.14
15	230	50	600	59	0.26	41	49	56	1660	71	975	0.29
16	230	50	600	55	0.24	46	54	60	1085	88	640	0.35

U = Power supply · f = Frequency · n = Speed (rpm) · P_{ed} = Power consumption · I = Current draw · LpA_{in} = Sound pressure level intake side · LwA_{in} = Sound power level intake side
 LwA_{out} = Sound power level outlet side · q_v = Air flow · p_{fs} = Pressure increase

