

R3G450-AL25-72 ebmpapst Datasheet

sales@fansco.com

www.fansco.com

Limited partnership · Headquarters Mulfingen

Amtsgericht (court of registration) Stuttgart · HRA 590344

General partner Elektrobau Mulfingen GmbH · Headquarters Mulfingen

Amtsgericht (court of registration) Stuttgart · HRB 590142

## Nominal data

Type	R3G450-AL25-72	
Motor	M3G084-FA	
Phase		1~
Nominal voltage	VAC	230
Nominal voltage range	VAC	200 .. 277
Frequency	Hz	50/60
Method of obtaining data		ml
Speed (rpm)	min <sup>-1</sup>	980
Power consumption	W	255
Current draw	A	1.6
Min. ambient temperature	°C	-25
Max. ambient temperature	°C	40

ml = Max. load · me = Max. efficiency · fa = Free air · cs = Customer specification · ce = Customer equipment  
Subject to change

## Data according to Commission Regulation (EU) 327/2011

		Actual	Req. 2015			
01 Overall efficiency $\eta_{es}$	%	60.8	45	09 Power consumption $P_{ed}$	kW	0.24
02 Measurement category		A		09 Air flow $q_v$	m <sup>3</sup> /h	2595
03 Efficiency category		Static		09 Pressure increase $p_{fs}$	Pa	185
04 Efficiency grade N		77.8	62	10 Speed (rpm) n	min <sup>-1</sup>	975
05 Variable speed drive		Yes		11 Specific ratio*		1.00

Data obtained at optimum efficiency level.

The ErP data is determined using a motor-impeller combination in a standardized measurement setup.

\* Specific ratio =  $1 + p_{fs} / 100\,000\text{ Pa}$ 

LU-114658



## Technical description

Weight	6.96 kg
Fan size	450 mm
Electronics housing material	Die-cast aluminum
Impeller material	PP-GF40 plastic
Number of blades	6
Direction of rotation	Clockwise, viewed toward rotor
Degree of protection	IP54
Insulation class	"B"
Moisture (F) / Environmental (H) protection class	H1
Max. permitted ambient temp. for motor (transport/storage)	+80 °C
Min. permitted ambient temp. for motor (transport/storage)	-40 °C
Installation position	Shaft horizontal or rotor on top; rotor on bottom on request
Condensation drainage holes	None
Mode	S1
Motor bearing	Ball bearing; (sealed)
Technical features	<ul style="list-style-type: none"> <li>- Control input 0-10 VDC / PWM</li> <li>- Output 10 VDC, max. 1.1 mA</li> <li>- Thermal overload protection for electronics/motor</li> <li>- Alarm relay</li> <li>- Line undervoltage detection</li> <li>- Motor current limitation</li> <li>- Soft start</li> </ul>
EMC immunity to interference	According to EN 61000-6-2 (industrial environment)
EMC circuit feedback	According to EN 61000-3-2/3
EMC interference emission	According to EN 61000-6-3 (household environment)
Touch current according to IEC 60990 (measuring circuit Fig. 4, TN system)	<= 3.5 mA
Motor protection	Thermal overload protector (TOP) internally connected
With cable	Variable
Protection class	I (with customer connection of protective earth)
Conformity with standards	CE
Approval	C22.2 No.77 + CAN/CSA-E60730-1; UL1004-3 +60730

Product drawing

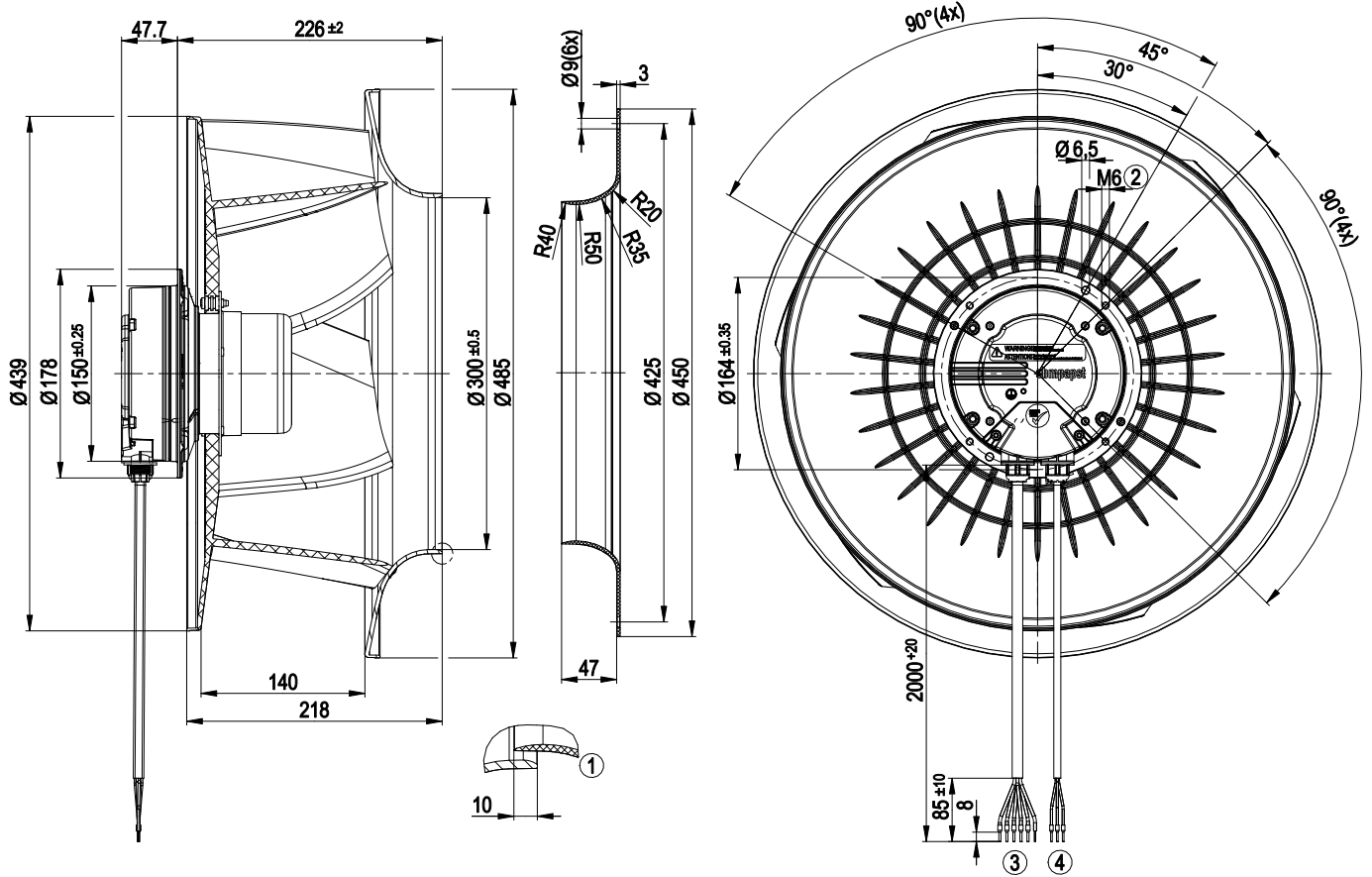

1	Accessory part: Inlet ring 45901-2-2943 not included in scope of delivery, other inlet rings on request
2	Clearance for screw 8-10 mm
3	Cable PVC AWG18, 5 x crimped ferrules
4	Cable PVC AWG22, 3 x crimped ferrules



## Connection diagram

Customer circuit

Application notes for various control options

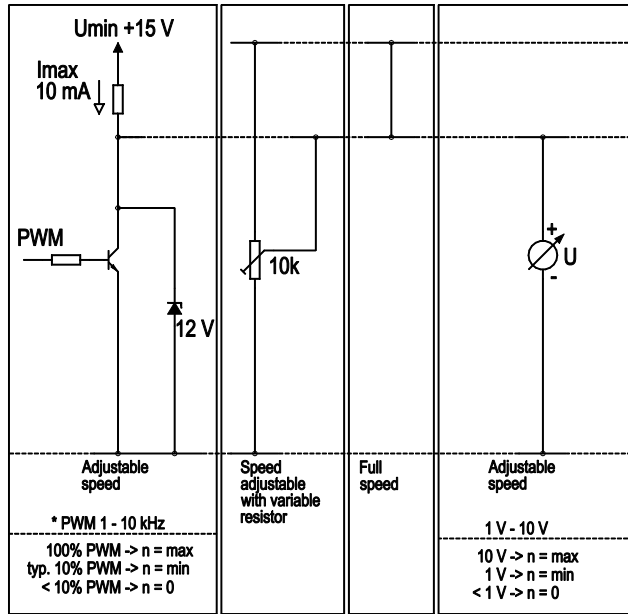

Connection

Fan / Motor

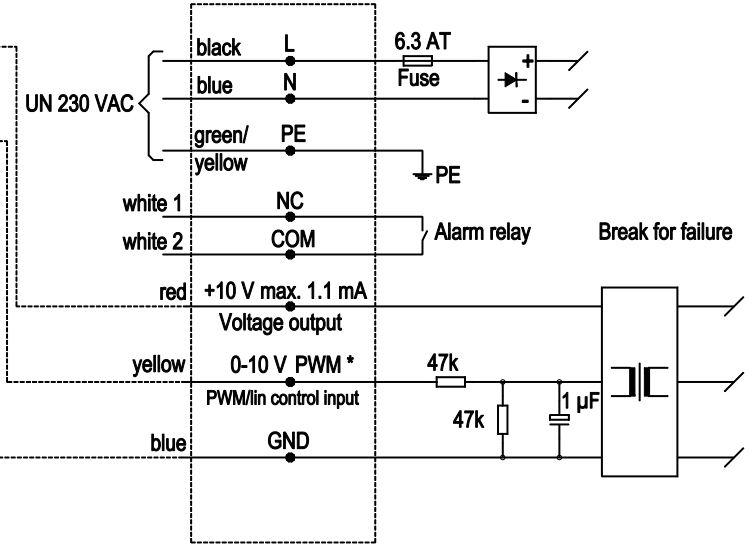

## Curves: Air performance 50 Hz

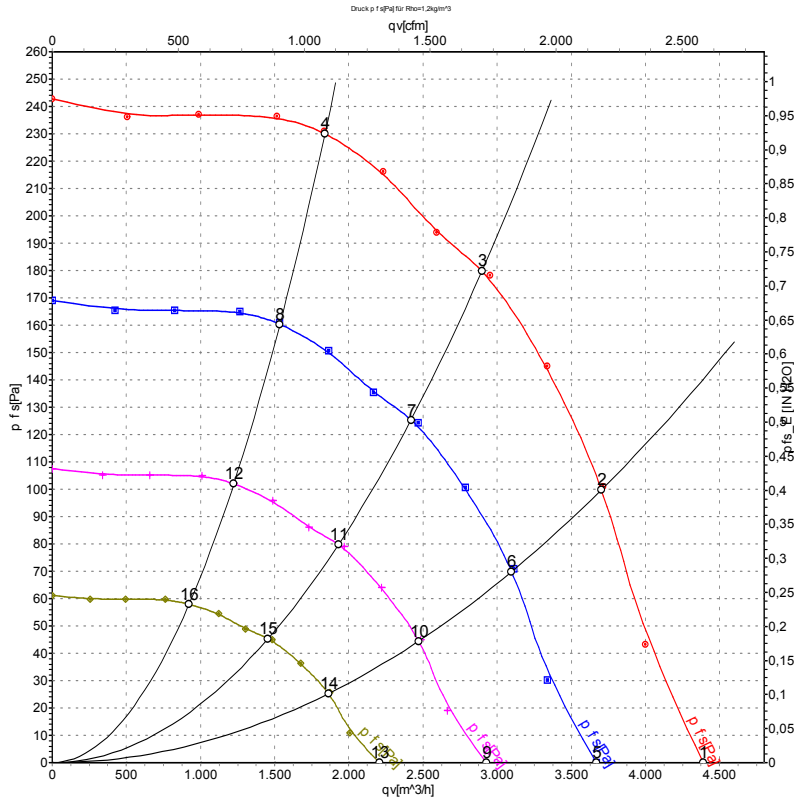

Measurement: LU-114658-1

Air performance measured according to ISO 5801 installation category A. For detailed information on the measurement setup, contact ebmpapst. Intake sound level: Sound power level according to ISO 13347 / sound pressure level measured at 1 m distance from fan axis. The values given are valid under the specified measuring conditions and may vary due to conditions of installation. For deviations from the standard configuration, the parameters have to be checked on the installed unit.

## Measured values

	U	f	n	P <sub>ed</sub>	I	LpA <sub>in</sub>	LwA <sub>in</sub>	LwA <sub>out</sub>	q <sub>v</sub>	P <sub>fs</sub>	q <sub>v</sub>	P <sub>fs</sub>
	V	Hz	min <sup>-1</sup>	W	A	dB(A)	dB(A)	dB(A)	m <sup>3</sup> /h	Pa	cfm	inH <sub>2</sub> O
1	230	50	980	157	1.02	62	69	76	4390	0	2585	0.00
2	230	50	980	207	1.31	58	65	72	3700	100	2180	0.40
3	230	50	980	255	1.60	53	61	67	2895	180	1705	0.72
4	230	50	980	231	1.45	55	63	69	1840	230	1080	0.92
5	230	50	815	92	0.60	58	66	72	3670	0	2160	0.00
6	230	50	815	122	0.77	54	61	68	3095	72	1825	0.29
7	230	50	815	149	0.92	49	57	63	2420	126	1425	0.51
8	230	50	815	135	0.84	51	59	65	1535	161	905	0.65
9	230	50	650	47	0.30	53	61	67	2925	0	1720	0.00
10	230	50	650	62	0.39	49	56	64	2470	46	1455	0.18
11	230	50	650	76	0.47	44	52	59	1930	80	1135	0.32
12	230	50	650	68	0.43	46	54	60	1225	102	720	0.41
13	230	50	490	20	0.13	47	55	61	2205	0	1300	0.00
14	230	50	490	26	0.17	43	50	57	1860	26	1095	0.10
15	230	50	490	32	0.20	38	46	52	1455	46	855	0.18
16	230	50	490	29	0.18	40	48	54	925	58	545	0.23

U = Power supply · f = Frequency · n = Speed (rpm) · P<sub>ed</sub> = Power consumption · I = Current draw · LpA<sub>in</sub> = Sound pressure level intake side · LwA<sub>in</sub> = Sound power level intake side  
 LwA<sub>out</sub> = Sound power level outlet side · q<sub>v</sub> = Air flow · P<sub>fs</sub> = Pressure increase

