

R3G450-AG33-90 ebmpapst Datasheet

sales@fansco.com

www.fansco.com

Limited partnership · Headquarters Mulfingen

Amtsgericht (court of registration) Stuttgart · HRA 590344

General partner Elektrobau Mulfingen GmbH · Headquarters Mulfingen

Amtsgericht (court of registration) Stuttgart · HRB 590142



Nominal data

Type	R3G450-AG33-90	
Motor	M3G112-GA	
Phase		3~
Nominal voltage	VAC	400
Nominal voltage range	VAC	380 .. 480
Frequency	Hz	50/60
Method of obtaining data		ml
Speed (rpm)	min ⁻¹	1550
Power consumption	W	1000
Current draw	A	1.85
Min. ambient temperature	°C	-25
Max. ambient temperature	°C	60

ml = Max. load · me = Max. efficiency · fa = Free air · cs = Customer specification · ce = Customer equipment
Subject to change

Data according to ErP Directive

		Actual	Req. 2015			
01 Overall efficiency η_{es}	%	63.5	51.5	09 Power consumption P_{ed}	kW	1
02 Measurement category		A		09 Air flow q_v	m ³ /h	4505
03 Efficiency category		Static		09 Pressure increase p_{fs}	Pa	470
04 Efficiency grade N		74	62	10 Speed (rpm) n	min ⁻¹	1555
05 Variable speed drive		Yes		11 Specific ratio*		1.00

Data obtained at optimum efficiency level.

The ErP data is determined using a motor-impeller combination in a standardized measurement setup.

* Specific ratio = $1 + p_{fs} / 100\,000\text{ Pa}$

LU-103318



Technical description

Weight	11 kg
Fan size	450 mm
Rotor surface	Painted black
Impeller material	Sheet aluminum, welded
Housing material	Die-cast aluminum
Number of blades	6
Direction of rotation	Clockwise, viewed toward rotor
Degree of protection	IP54
Insulation class	"B"
Moisture (F) / Environmental (H) protection class	F4-1
Max. permitted ambient temp. for motor (transport/storage)	+ 80 °C
Min. permitted ambient temp. for motor (transport/storage)	- 40 °C
Installation position	Shaft horizontal or rotor on bottom; rotor on top on request
Condensation drainage holes	On rotor side
Mode	S1
Motor bearing	Ball bearing
Technical features	<ul style="list-style-type: none"> - Output 10 VDC, max. 10 mA - Output 20 VDC, max. 50 mA - Output for slave 0-10 V - Input for sensor 0-10 V or 4-20 mA - Alarm relay - Integrated PID controller - Motor current limitation - PFC, passive - RS-485 MODBUS - Soft start - Control input 0-10 VDC / PWM - Control interface with SELV potential safely disconnected from supply - Thermal overload protection for electronics/motor - Undervoltage / phase failure detection
EMC immunity to interference	According to EN 61000-6-2
EMC circuit feedback	According to EN 61000-3-2/3
EMC interference emission	According to EN 61000-6-3 (household environment)
Touch current according to IEC 60990 (measuring circuit Fig. 4, TN system)	<= 3.5 mA
Electrical hookup	Via terminal box
Motor protection	Thermal overload protector (TOP) internally connected
With cable	Variable
Protection class	I (with customer connection of protective earth)
Conformity with standards	EN 61800-5-1; CE
Approval	CSA C22.2 No. 77; UL 1004-7 + 60730

Product drawing

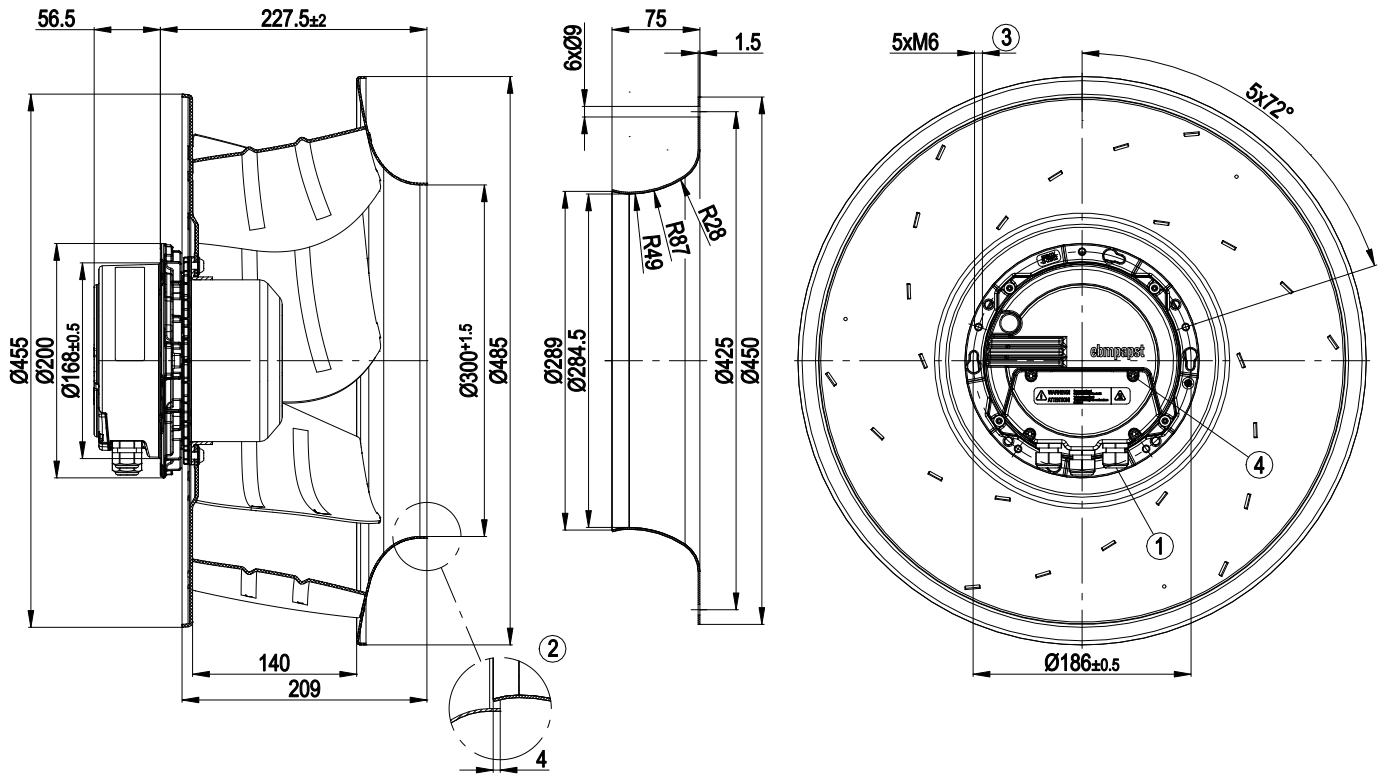

1	Cable diameter min. 4 mm, max. 10 mm; tightening torque 4 \pm 0.6 Nm
2	Accessory part: Inlet ring 45075-2-4013 with pressure tap not included in scope of delivery, other inlet rings on request
3	Clearance for screw 12 - 16 mm
4	Tightening torque 3.5 \pm 0.5 Nm

Connection diagram

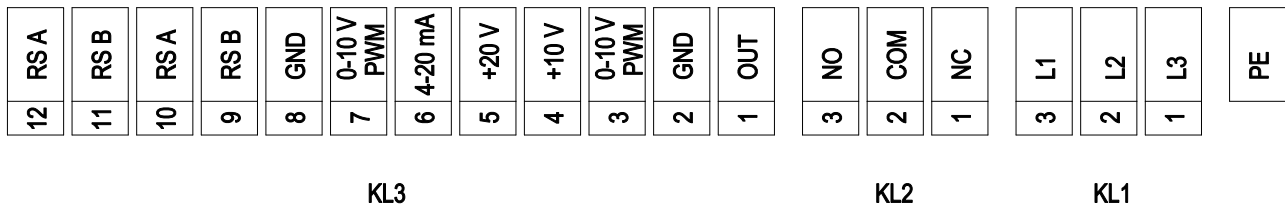

No.	Conn.	Designation	Color	Function/assignment
PE	-	PE	green/yellow	Protective earth terminal
KL1	1, 2, 3	L1, L2, L3	black	Power supply, voltage range see nameplate, 50/60 Hz
KL2	1	NC	white 1	Floating status contact, break for failure
KL2	2	COM	white 2	Floating status contact, changeover contact, common connection (2A, max. 250 VAC, min. 10 mA, AC1)
KL2	3	NO		Floating status contact, make for failure
KL3	1	OUT		Analog output, 0-10 VDC, max. 3 mA, SELV Output of current motor modulation level: 1 V corresponds to 10% modulation level. 10 V corresponds to 100% modulation level.
KL3	2, 8	GND	blue	Reference ground for control interface, SELV
KL3	3, 7	0-10V	yellow	Use control/current sensor value input 0-10 VDC, impedance 100 kohms only as alternative to 4-20 mA input, SELV
KL3	4	+10V	red	Voltage output 10 VDC (+/- 3%), max. 10 mA, power supply for ext. devices (e.g. potentiometers), SELV
KL3	5	+20V		Voltage output 20 VDC (+25%/-10%), max. 50 mA, power supply for ext. devices (e.g. sensors), SELV
KL3	6	4-20mA		Control/current sensor value input 4-20 mA, impedance 100 ohms, use only as alternative to 0-10 V input, SELV
KL3	9, 11	RSB	black	RS485 interface for MODBUS, RSB, SELV
KL3	10, 12	RSA	orange	RS485 interface for MODBUS, RSA, SELV

Curves: Air performance 50 Hz

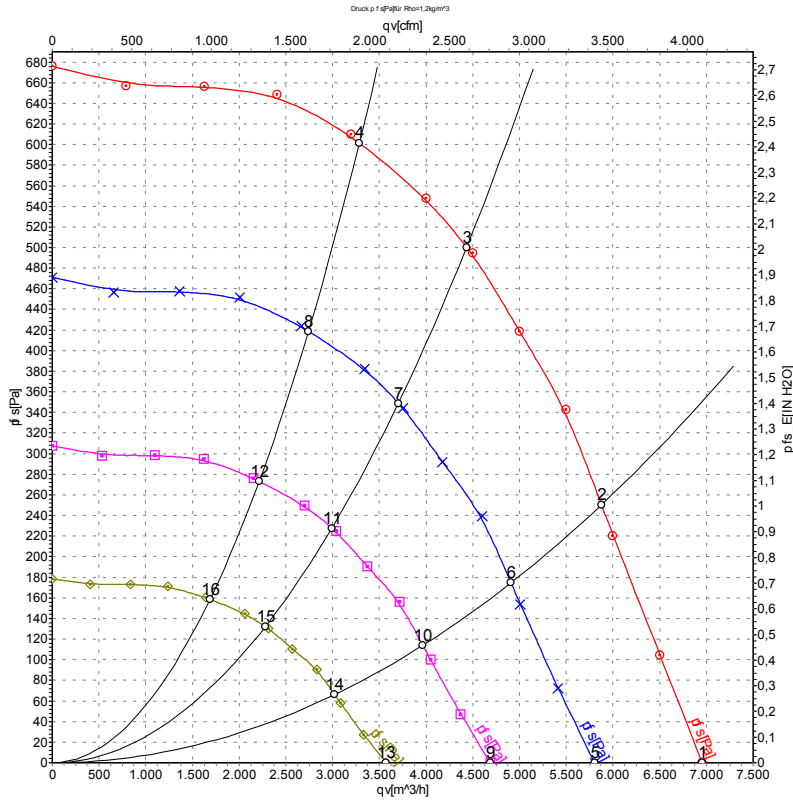

Measurement: LU-103318-1

Air performance measured according to ISO 5801 installation category A. For detailed information on the measurement setup, contact ebm-papst. Intake sound level: Sound power level according to ISO 13347 / sound pressure level measured at 1 m distance from fan axis. The values given are valid under the specified measuring conditions and may vary due to conditions of installation. For deviations from the standard configuration, the parameters have to be checked on the installed unit.

Measured values

	U	f	n	P _{ed}	I	LpA _{in}	LwA _{in}	LwA _{out}	qv	P _{fs}	qv	P _{fs}
	V	Hz	min ⁻¹	W	A	dB(A)	dB(A)	dB(A)	m ³ /h	Pa	CFM	inH2O
1	400	50	1550	687	1.14	77	84	88	6955	0	4095	0.00
2	400	50	1550	894	1.43	71	78	84	5880	250	3460	1.00
3	400	50	1550	1000	1.85	66	74	80	4435	500	2610	2.01
4	400	50	1550	962	1.54	70	77	84	3285	600	1935	2.41
5	400	50	1300	399	0.66	73	80	84	5805	0	3415	0.00
6	400	50	1300	521	0.83	67	74	80	4910	175	2890	0.70
7	400	50	1300	586	0.94	63	70	76	3705	350	2180	1.41
8	400	50	1300	558	0.90	66	73	80	2740	420	1615	1.69
9	400	50	1050	210	0.35	68	75	79	4685	0	2760	0.00
10	400	50	1050	274	0.44	63	70	76	3965	114	2335	0.46
11	400	50	1050	309	0.50	58	65	72	2990	228	1760	0.92
12	400	50	1050	294	0.47	61	69	76	2215	274	1305	1.10
13	400	50	800	93	0.15	62	69	74	3570	0	2100	0.00
14	400	50	800	121	0.19	57	64	70	3020	66	1780	0.26
15	400	50	800	136	0.22	52	59	66	2280	132	1340	0.53
16	400	50	800	130	0.21	55	63	70	1685	159	995	0.64

U = Power supply · f = Frequency · n = Speed (rpm) · P_{ed} = Power consumption · I = Current draw · LpA_{in} = Sound pressure level intake side · LwA_{in} = Sound power level intake side
 LwA_{out} = Sound power level outlet side · qv = Air flow · p_{fs} = Pressure increase

