

R3G400-RS03-H3 ebmpapst Datasheet

sales@fansco.com

www.fansco.com

Limited partnership · Headquarters Mulfingen

Amtsgericht (court of registration) Stuttgart · HRA 590344

General partner Elektrobau Mulfingen GmbH · Headquarters Mulfingen

Amtsgericht (court of registration) Stuttgart · HRB 590142

## Nominal data

Type	R3G400-RS03-H3	
Motor	M3G084-FA	
Phase		1~
Nominal voltage	VAC	230
Nominal voltage range	VAC	200 .. 277
Frequency	Hz	50/60
Method of obtaining data		ml
Speed (rpm)	min <sup>-1</sup>	1500
Power consumption	W	500
Current draw	A	2.2
Min. ambient temperature	°C	-25
Max. ambient temperature	°C	50

ml = Max. load · me = Max. efficiency · fa = Free air · cs = Customer specification · ce = Customer equipment  
Subject to change

## Data according to Commission Regulation (EU) 327/2011

		Actual	Req. 2015			
01 Overall efficiency $\eta_{es}$	%	66.4	48.4	09 Power consumption $P_{ed}$	kW	0.51
02 Measurement category		A		09 Air flow $q_v$	m <sup>3</sup> /h	3200
03 Efficiency category		Static		09 Pressure increase $p_{fs}$	Pa	345
04 Efficiency grade N		80	62	10 Speed (rpm) n	min <sup>-1</sup>	1480
05 Variable speed drive		Yes		11 Specific ratio <sup>*</sup>		1.00

Data obtained at optimum efficiency level.

The ErP data is determined using a motor-impeller combination in a standardized measurement setup.

<sup>\*</sup> Specific ratio =  $1 + p_{fs} / 100\,000\text{ Pa}$ 

LU-183601



## Technical description

Weight	5.4 kg
Fan size	400 mm
Rotor surface	Painted black
Electronics housing material	Die-cast aluminum
Impeller material	PP plastic (black)
Number of blades	6
Direction of rotation	Clockwise, viewed toward rotor
Degree of protection	IP55
Insulation class	"F"
Moisture (F) / Environmental (H) protection class	H1
Max. permitted ambient temp. for motor (transport/storage)	+80 °C
Min. permitted ambient temp. for motor (transport/storage)	-40 °C
Installation position	Shaft horizontal or rotor on bottom; rotor on top on request
Condensation drainage holes	On rotor side
Mode	S1
Motor bearing	Ball bearing
Technical features	<ul style="list-style-type: none"> <li>- Output 10 VDC, max. 10 mA</li> <li>- Operation and alarm display</li> <li>- Alarm relay</li> <li>- Integrated PID controller</li> <li>- Power limiter</li> <li>- Motor current limitation</li> <li>- PFC, active</li> <li>- RS-485 MODBUS-RTU</li> <li>- Soft start</li> <li>- Control input 0-10 VDC / PWM</li> <li>- Control interface with SELV potential safely disconnected from the mains</li> <li>- Thermal overload protection for electronics/motor</li> <li>- Line undervoltage / phase failure detection</li> </ul>
EMC immunity to interference	According to EN 61000-6-2 (industrial environment)
EMC circuit feedback	According to EN 61000-3-2/3
EMC interference emission	According to EN 61000-6-3 (household environment)
Touch current according to IEC 60990 (measuring circuit Fig. 4, TN system)	<= 3.5 mA
Motor protection	Thermal overload protector (TOP) internally connected
With cable	Variable
Protection class	I (with customer connection of protective earth)
Conformity with standards	EN 61800-5-1; EN 60335-1; CE
Approval	C22.2 No.77 + CAN/CSA-E60730-1; UL 1004-7 + 60730; EAC

Product drawing

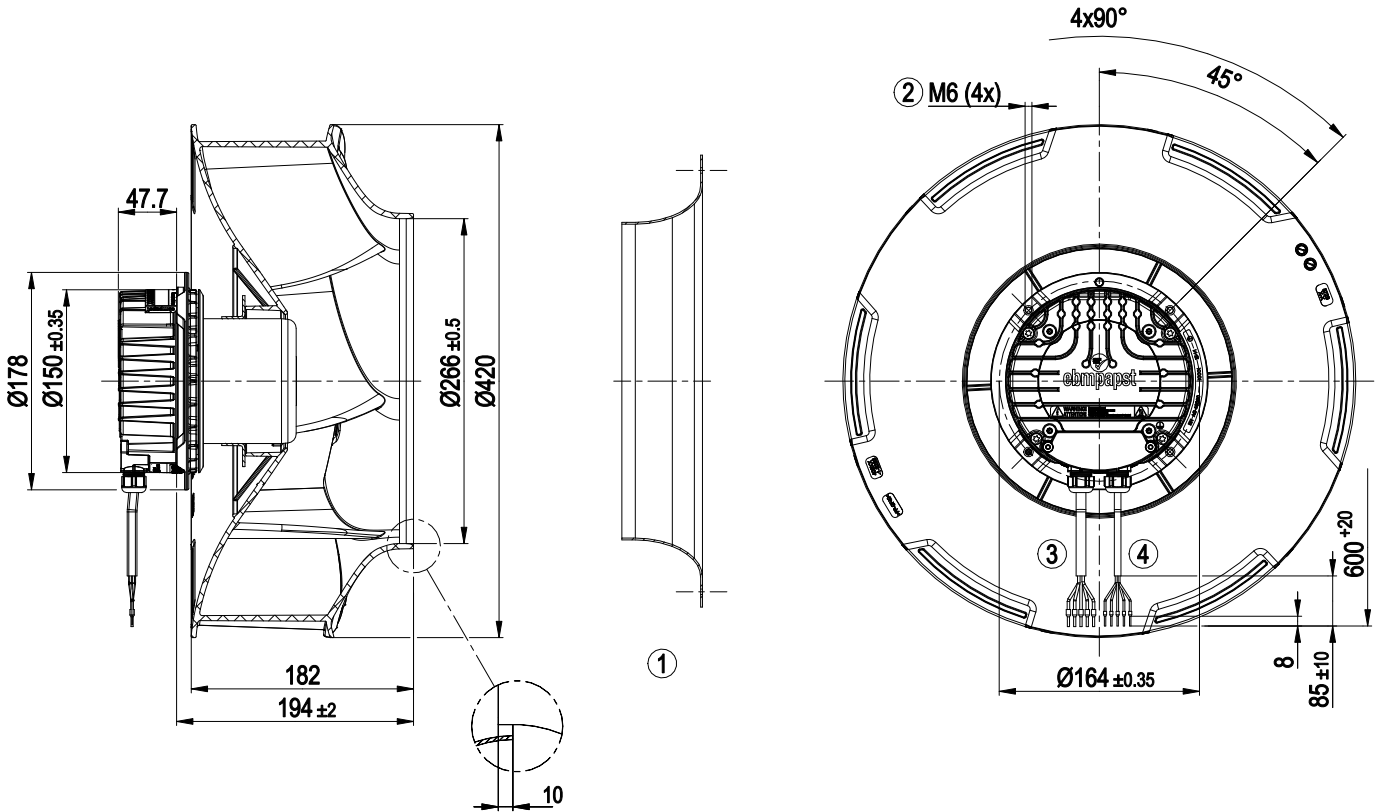

1	Accessory part: Inlet ring 54476-2-4013 not included in scope of delivery.
2	Max. clearance for screw 16 mm
3	Cable PVC AWG18, 5x crimped ferrules
4	Cable PVC AWG22, 5x crimped ferrules

## Accessory part

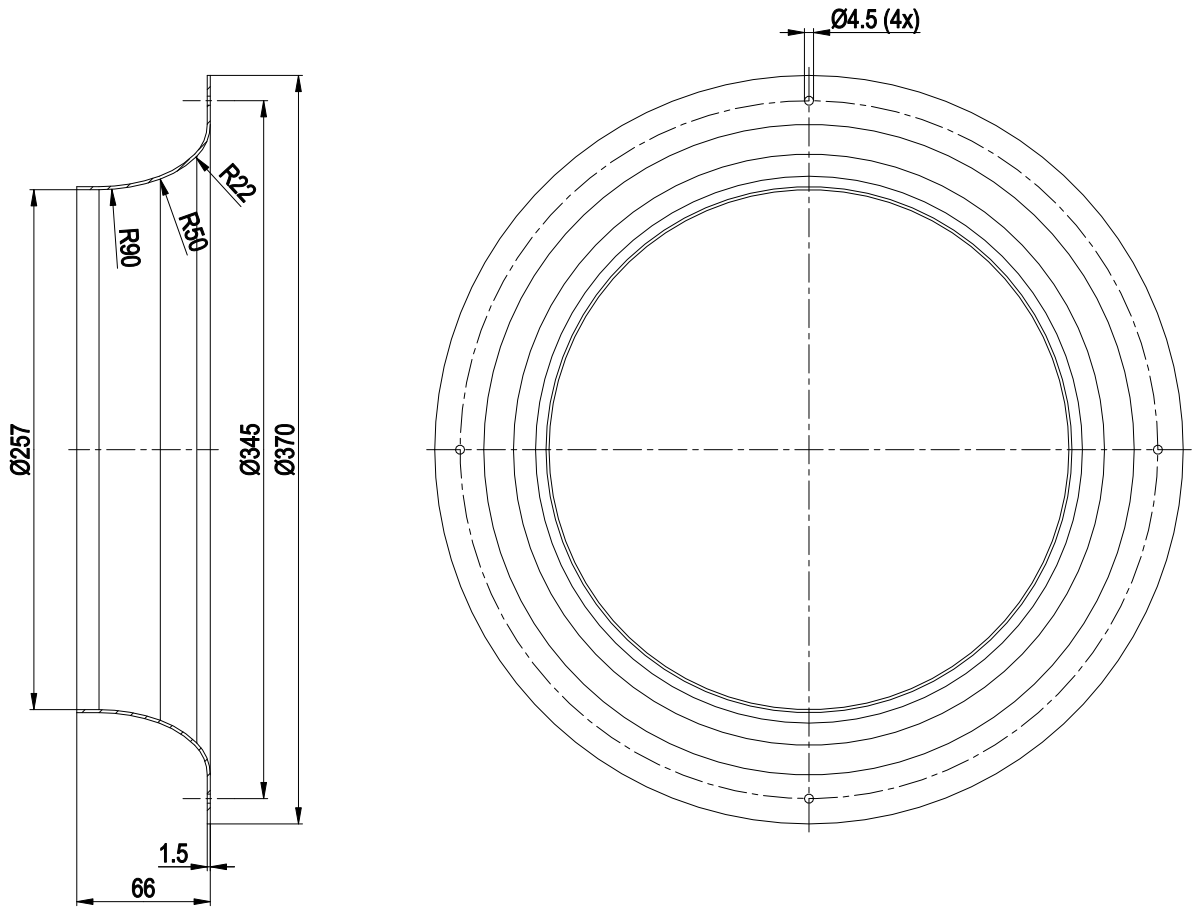

Inlet ring 54476-2-4013 not included in scope of delivery

## Connection diagram



No.	Conn.	Designation	Color	Function/assignment
1	1, 2	PE	green/yellow	Protective earth
1	3	N	blue	Power supply, neutral conductor, 50/60 Hz
1	5	L	black	Power supply, phase, 50/60 Hz
1	6	NC	white 1	Status relay, floating status contact; break for failure, contact rating 250 VAC / 2A (AC1) / min. 10 mA, basic insulation on supply side and reinforced insulation on control interface side
1	7	COM	white 2	Status relay, floating status contact; common connection, contact rating 250 VAC / 2A (AC1) / min. 10 mA, basic insulation on supply side and reinforced insulation on control interface side
2	8	0-10V	yellow	Analog input (set value); 0-10 V; $R_i = 100\text{ k}\Omega$ ; adjustable curve
2	10	RSB	brown	RS485 interface for MODBUS, RSB
2	11	RSA	white	RS485 interface for MODBUS, RSA
2	12	GND	blue	Reference ground for control interface, SELV
2	13	+10V	red	Fixed voltage output 10 VDC, +10 V $\pm 3\%$ ; max. 10 mA; short-circuit-proof; power supply for external devices (e.g. pot)



## Curves: Air performance 50 Hz

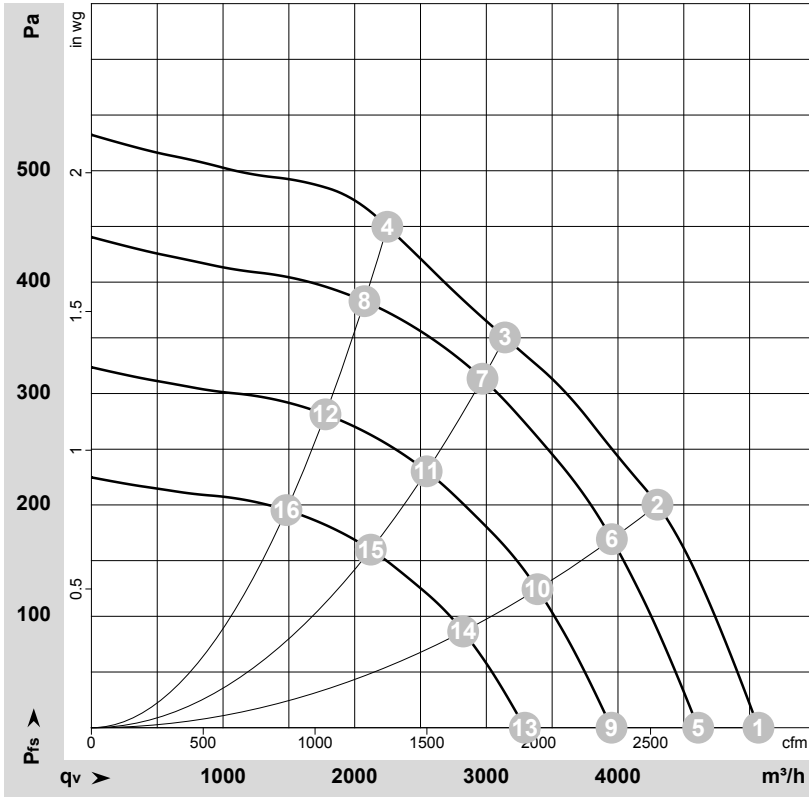

$\rho = 1.15 \text{ kg/m}^3 \pm 2 \%$

Measurement: LU-183601-1

Air performance measured according to ISO 5801 installation category A. For detailed information on the measurement setup, contact ebmpapst. Intake sound level: Sound power level according to ISO 13347 / sound pressure level measured at 1 m distance from fan axis. The values given are valid under the specified measuring conditions and may vary due to conditions of installation. For deviations from the standard configuration, the parameters have to be checked on the installed unit.

## Measured values

	U	f	n	P <sub>ed</sub>	I	q <sub>v</sub>	P <sub>fs</sub>	q <sub>v</sub>	P <sub>fs</sub>
	V	Hz	min <sup>-1</sup>	W	A	m <sup>3</sup> /h	Pa	cfm	in. wg
1	230	50	1535	395	1.73	5065	0	2980	0.00
2	230	50	1525	500	2.20	4300	200	2530	0.80
3	230	50	1500	500	2.20	3140	350	1850	1.41
4	230	50	1515	500	2.20	2250	450	1325	1.81
5	230	50	1400	297	1.30	4610	0	2715	0.00
6	230	50	1400	406	1.78	3955	170	2325	0.68
7	230	50	1400	433	1.90	2970	314	1750	1.26
8	230	50	1400	411	1.80	2075	383	1220	1.54
9	230	50	1200	187	0.82	3950	0	2325	0.00
10	230	50	1200	256	1.12	3390	125	1995	0.50
11	230	50	1200	273	1.20	2545	231	1500	0.93
12	230	50	1200	259	1.13	1780	281	1045	1.13
13	230	50	1000	108	0.48	3295	0	1940	0.00
14	230	50	1000	148	0.65	2825	87	1660	0.35
15	230	50	1000	158	0.69	2120	160	1250	0.64
16	230	50	1000	150	0.65	1480	195	870	0.78

U = Power supply · f = Frequency · n = Speed (rpm) · P<sub>ed</sub> = Power consumption · I = Current draw · q<sub>v</sub> = Air flow · p<sub>fs</sub> = Pressure increase

