

R3G400-RP46-35 ebmpapst Datasheet

sales@fansco.com

www.fansco.com

Limited partnership · Headquarters Muldingen

Amtsgericht (court of registration) Stuttgart · HRA 590344

General partner Elektrobau Muldingen GmbH · Headquarters Muldingen

Amtsgericht (court of registration) Stuttgart · HRB 590142

## Nominal data

Type	R3G400-RP46-35	
Motor	M3G084-FA	
Nominal voltage	VDC	48
Nominal voltage range	VDC	36 .. 57
Method of obtaining data		fa
Speed (rpm)	min <sup>-1</sup>	1430
Power consumption	W	285
Current draw	A	6
Min. ambient temperature	°C	-25
Max. ambient temperature	°C	40

ml = Max. load · me = Max. efficiency · fa = Free air · cs = Customer specification · ce = Customer equipment  
Subject to change

## Data according to Commission Regulation (EU) 327/2011

		Actual	Req. 2015			
01 Overall efficiency $\eta_{es}$	%	68.8	46.8	09 Power consumption $P_e$	kW	0.36
02 Measurement category		A		09 Air flow $q_v$	m <sup>3</sup> /h	2800
03 Efficiency category		Static		09 Pressure increase $p_{fs}$	Pa	291
04 Efficiency grade N		84	62	10 Speed (rpm) n	min <sup>-1</sup>	1355
05 Variable speed drive		Yes		11 Specific ratio*		1.00

Data obtained at optimum efficiency level.  
The ErP data is determined using a motor-impeller combination in a standardized measurement setup.

\* Specific ratio =  $1 + p_{fs} / 100\,000\text{ Pa}$ 

LU-154601



## Technical description

Weight	5.9 kg
Fan size	400 mm
Rotor surface	Painted black
Electronics housing material	Die-cast aluminum
Impeller material	PP plastic UL
Number of blades	6
Direction of rotation	Clockwise, viewed toward rotor
Degree of protection	IP42
Insulation class	"B"
Moisture (F) / Environmental (H) protection class	H1
Max. permitted ambient temp. for motor (transport/storage)	+80 °C
Min. permitted ambient temp. for motor (transport/storage)	-40 °C
Installation position	Shaft horizontal or rotor on top; rotor on bottom on request
Condensation drainage holes	None
Mode	S1
Motor bearing	Ball bearing
Technical features	<ul style="list-style-type: none"> <li>- Tach output</li> <li>- Power limiter</li> <li>- Motor current limitation</li> <li>- Soft start</li> <li>- Control input 0-10 VDC / PWM</li> <li>- Thermal overload protection for motor</li> </ul>
Motor protection	Thermal overload protector (TOP) internally connected
With cable	Variable
Protection class	I (with customer connection of protective earth)
Conformity with standards	EN 61800-5-1; CE
Approval	UL 1004-1; CSA C22.2 No. 100

Product drawing

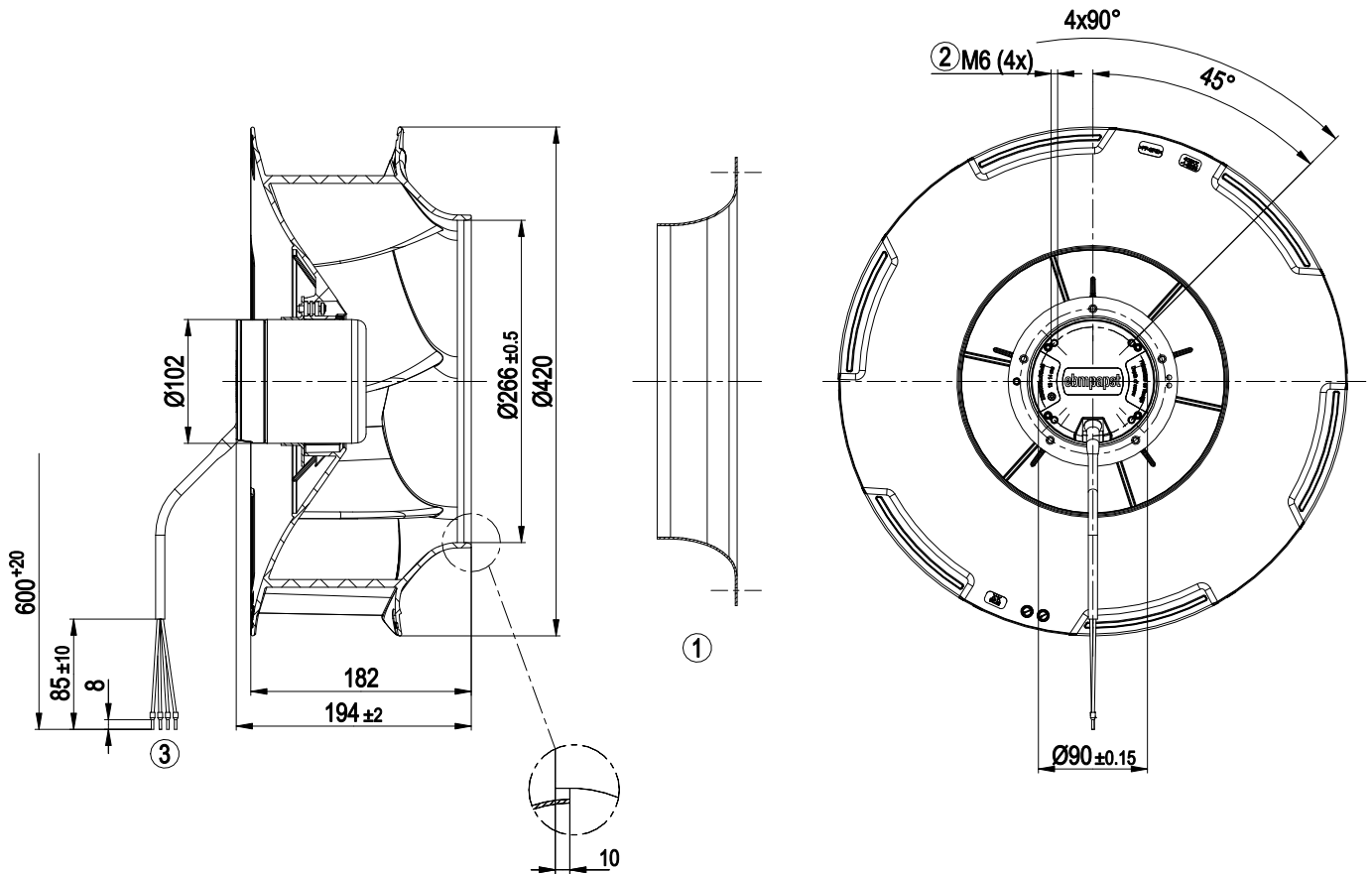

1	Accessory part: inlet ring 54476-2-4013 not included in scope of delivery
2	Max. clearance for screw 10 mm
3	Cable PVC AWG16, 4x crimped ferrules



## Accessory part

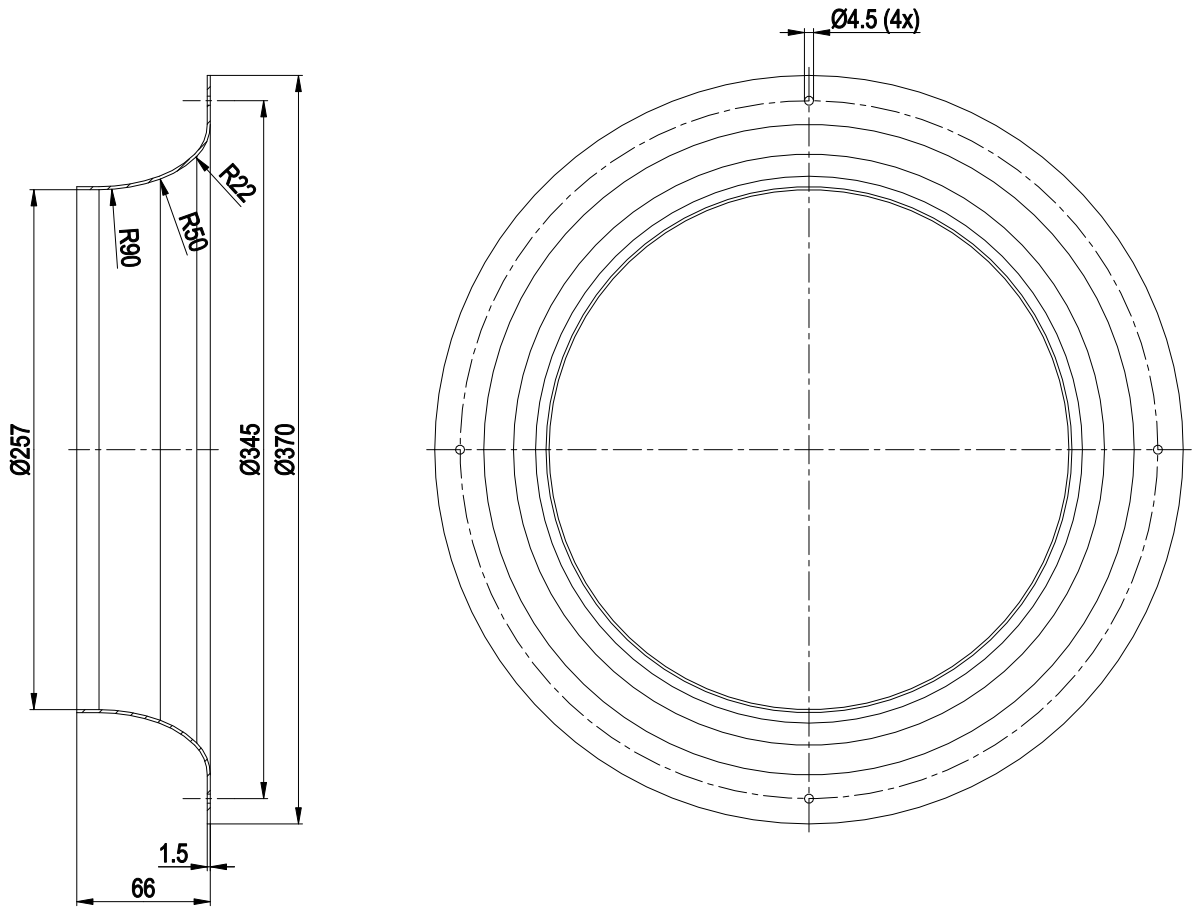

Inlet ring 54476-2-4013 not included in scope of delivery



## Connection diagram

**Customer circuit**

**Application notes for various control options**

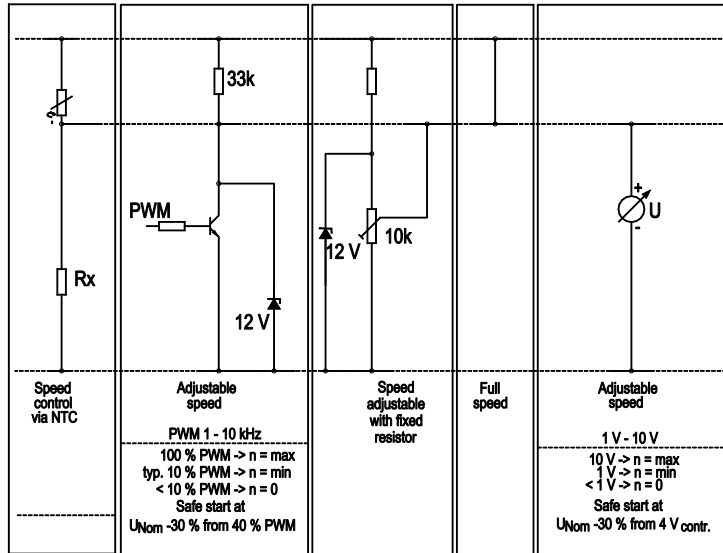

**Connection**  
Supply voltage ripple  $\pm 3.5\%$

**Fan / Motor**

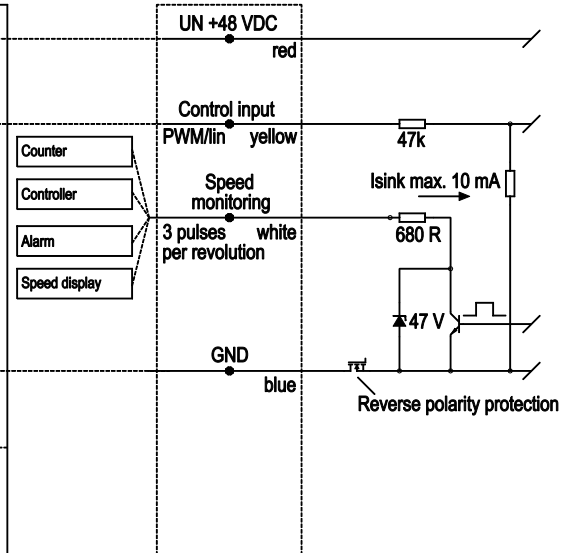

## Curves: Air performance

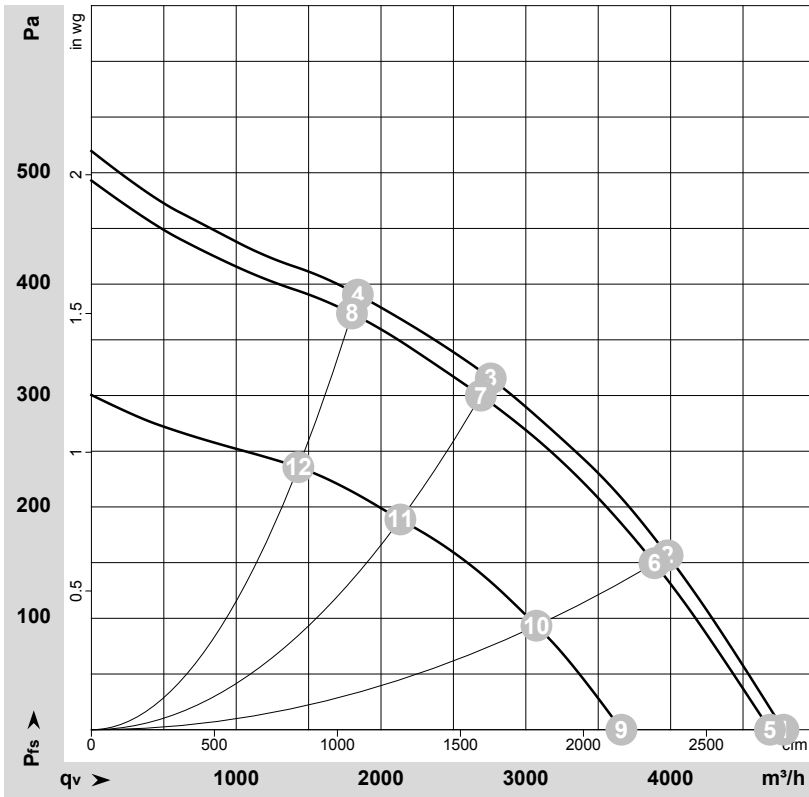

$\rho = 1.15 \text{ kg/m}^3 \pm 2 \%$

Measurement: LU-154602-1  
 Measurement: LU-154601-1  
 Measurement: LU-154603-1

Air performance measured according to ISO 5801 installation category A. For detailed information on the measurement setup, contact ebmpapst. Intake sound level: Sound power level according to ISO 13347 / sound pressure level measured at 1 m distance from fan axis. The values given are valid under the specified measuring conditions and may vary due to conditions of installation. For deviations from the standard configuration, the parameters have to be checked on the installed unit.

## Measured values

	U	n	P <sub>ed</sub>	I	q <sub>v</sub>	p <sub>fs</sub>	q <sub>v</sub>	p <sub>fs</sub>
	V	min <sup>-1</sup>	W	A	m <sup>3</sup> /h	Pa	cfm	in. wg
1	57	1460	307	5.45	4780	0	2815	0.00
2	57	1405	375	6.70	3980	158	2340	0.63
3	57	1390	396	7.06	2760	316	1625	1.27
4	57	1405	372	6.62	1840	391	1085	1.57
5	48	1430	285	6.00	4685	0	2760	0.00
6	48	1370	350	7.39	3890	150	2290	0.60
7	48	1355	366	7.74	2690	300	1585	1.20
8	48	1375	346	7.30	1800	375	1060	1.51
9	36	1125	140	3.93	3660	0	2155	0.00
10	36	1090	173	4.85	3075	94	1810	0.38
11	36	1080	184	5.15	2135	189	1255	0.76
12	36	1095	173	4.83	1430	236	840	0.95

U = Power supply · n = Speed (rpm) · P<sub>ed</sub> = Power consumption · I = Current draw · q<sub>v</sub> = Air flow · p<sub>fs</sub> = Pressure increase

