

R3G400-RP45-54 ebmpapst Datasheet

sales@fansco.com

www.fansco.com

Limited partnership · Headquarters Mulfingen

Amtsgericht (court of registration) Stuttgart · HRA 590344

General partner Elektrobau Mulfingen GmbH · Headquarters Mulfingen

Amtsgericht (court of registration) Stuttgart · HRB 590142

Nominal data

Type	R3G400-RP45-54	
Motor	M3G084-FA	
Phase		1~
Nominal voltage	VAC	230
Nominal voltage range	VAC	200 .. 277
Frequency	Hz	50/60
Method of obtaining data		ml
Speed (rpm)	min ⁻¹	1248
Power consumption	W	320
Current draw	A	1.7 (200V)
Min. ambient temperature	°C	-25
Max. ambient temperature	°C	40

ml = Max. load · me = Max. efficiency · fa = Free air · cs = Customer specification · ce = Customer equipment
Subject to change

Data according to Commission Regulation (EU) 327/2011

		Actual	Req. 2015			
01 Overall efficiency η_{es}	%	62.3	46.2	09 Power consumption P_{ed}	kW	0.31
02 Measurement category		A		09 Air flow q_v	m ³ /h	2400
03 Efficiency category		Static		09 Pressure increase p_{fs}	Pa	259
04 Efficiency grade N		78.1	62	10 Speed (rpm) n	min ⁻¹	1260
05 Variable speed drive		Yes		11 Specific ratio [*]		1.00

Data obtained at optimum efficiency level.

The ErP data is determined using a motor-impeller combination in a standardized measurement setup.

^{*} Specific ratio = $1 + p_{fs} / 100\,000\text{ Pa}$

LU-151921



Technical description

Weight	6.3 kg
Size	400 mm
Motor size	84
Rotor surface	Painted black
Electronics housing material	Die-cast aluminum
Impeller material	PP plastic
Number of blades	6
Direction of rotation	Clockwise, viewed toward rotor
Degree of protection	IP20
Insulation class	"B"
Moisture (F) / Environmental (H) protection class	H0 - dry environment
Max. permitted ambient temp. for motor (transport/storage)	+80 °C
Min. permitted ambient temp. for motor (transport/storage)	-40 °C
Installation position	Shaft horizontal or rotor on top; rotor on bottom on request
Condensation drainage holes	None
Mode	S1
Motor bearing	Ball bearing
Technical features	<ul style="list-style-type: none"> - Operation and alarm display with LED - Integrated PID controller - Motor current limitation - PFC, active - RS485 ebmBUS with DCI function - Soft start - Control interface with SELV potential safely disconnected from the mains - Thermal overload protection for electronics/motor - Line undervoltage / phase failure detection
EMC immunity to interference	According to EN 61000-6-2 (industrial environment)
EMC circuit feedback	According to EN 61000-3-2/3
EMC interference emission	According to EN 61000-6-4 (industrial environment)
Touch current according to IEC 60990 (measuring circuit Fig. 4, TN system)	<= 3.5 mA
Electrical hookup	Connector with cable
Motor protection	Thermal overload protector (TOP) internally connected
With cable	Variable
Protection class	I (with customer connection of protective earth)
Conformity with standards	EN 61800-5-1; CE
Approval	CSA C22.2 No. 77 + CAN/CSA-E60730-1; EAC; UL 1004-3 + 60730-1

Product drawing

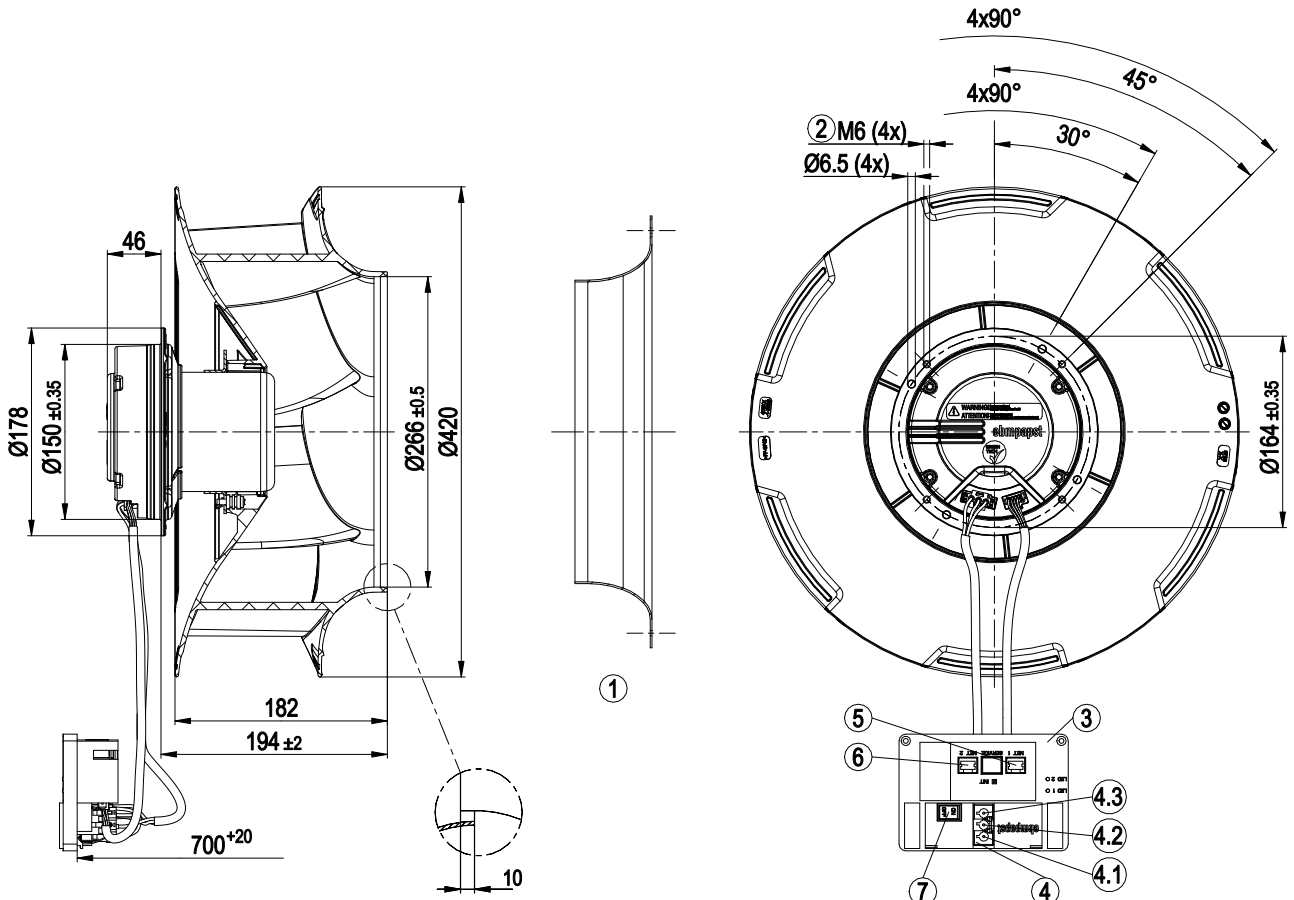

1	Accessory part: inlet ring 54476-2-4013 not included in scope of delivery
2	Max. clearance for screw 10 mm
3	Terminal box
4	Connector housing 3-pole GST18/3 Wieland 92.032.9058.1
4.1	N
4.2	PE
4.3	L
5	8-pole connector housing TE 100616-2
6	8-pole connector housing TE 100616-2
7	Switch, ARCOLECTRIC SWITCHES P L C (no. H8550VBACF) As-delivered condition end customer switch set to "OFF"



Accessory part

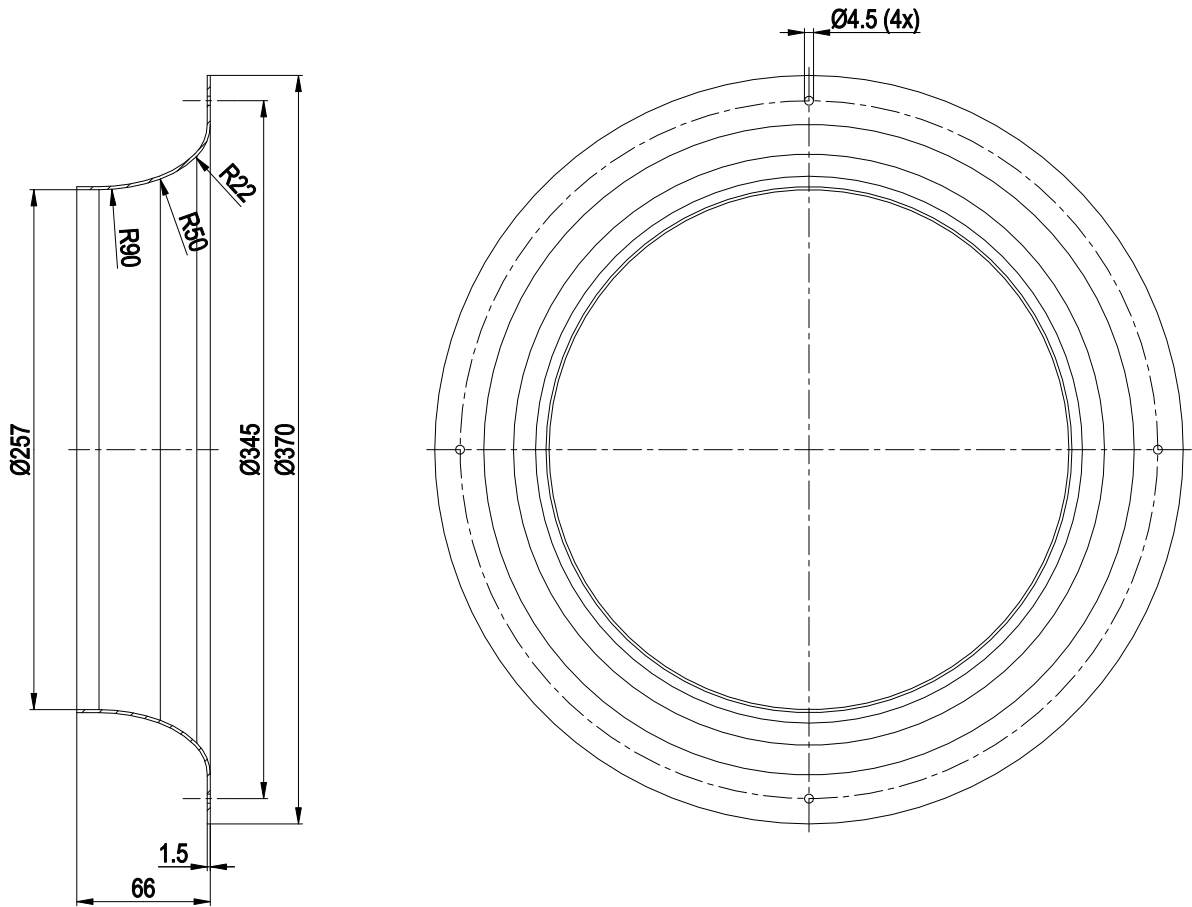

Inlet ring 54476-2-4013 not included in scope of delivery



Connection diagram

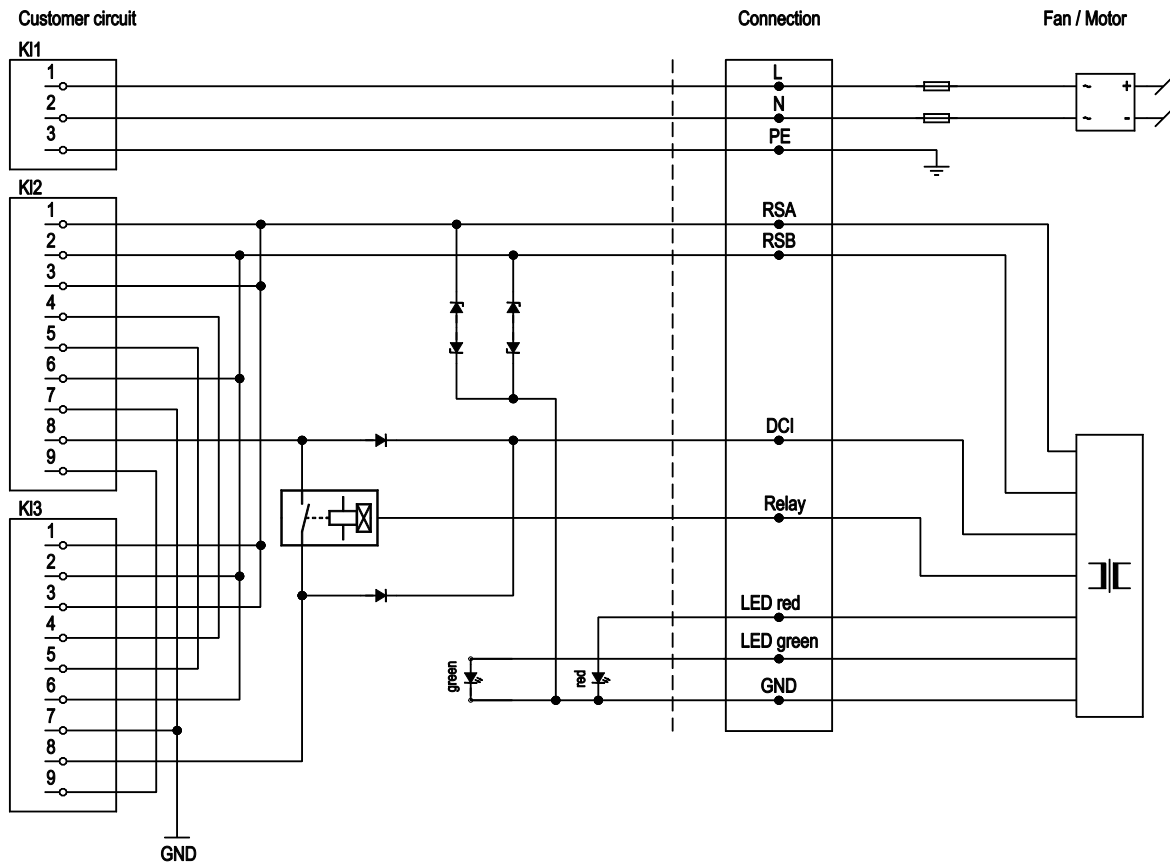

LED1 / LED2

Status	Priority	Address S/N	Speed	green LED	red LED
Malfunction	1	S/N any	any	off	flashing 1 Hz
Flashing	2	S/N = 1/1	any	flashing 10 Hz	on
Flashing	2	S/N < 1	any	flashing 10 Hz	off
after set value change	3	S/N = 1/1	any	flashing 3 times at 2.5 Hz	on
after set value change	3	S/N < 1	any	flashing 3 times at 2.5 Hz	off
Fan speed 0	4	S/N = 1/1	n = 0	flashing 1 Hz	on
Fan speed 0	4	S/N < 1	n = 0	flashing 1 Hz	off
Fan speed > 0	4	S/N = 1/1	n > 0	off	on
Fan speed > 0	4	S/N < 1	n > 0	on	off

No.	Conn.	Designation	Function/assignment
KL1	1	L	Power supply, phase, 50/60 Hz
KL1	2	N	Power supply, neutral conductor, 50/60 Hz
KL1	3	PE	Protective earth
KL2/KL3	1	RSA	RS485 interface for ebmBUS, RSA
KL2/KL3	2	RSB	RS485 interface for ebmBUS, RSB
KL2/KL3	3	RSA	RS485 interface for ebmBUS, RSA
KL2/KL3	4	-	Bridge KL2-KL3
KL2/KL3	5	-	Bridge KL2-KL3
KL2/KL3	6	RSB	RS485 interface for ebmBUS, RSB
KL2/KL3	7	GND	Reference ground
KL2/KL3	8	DCI	Daisy chain signal
KL2/KL3	9	Schirm	Shield for RJ45 CAT5 wire (not used)



Curves: Air performance 50 Hz

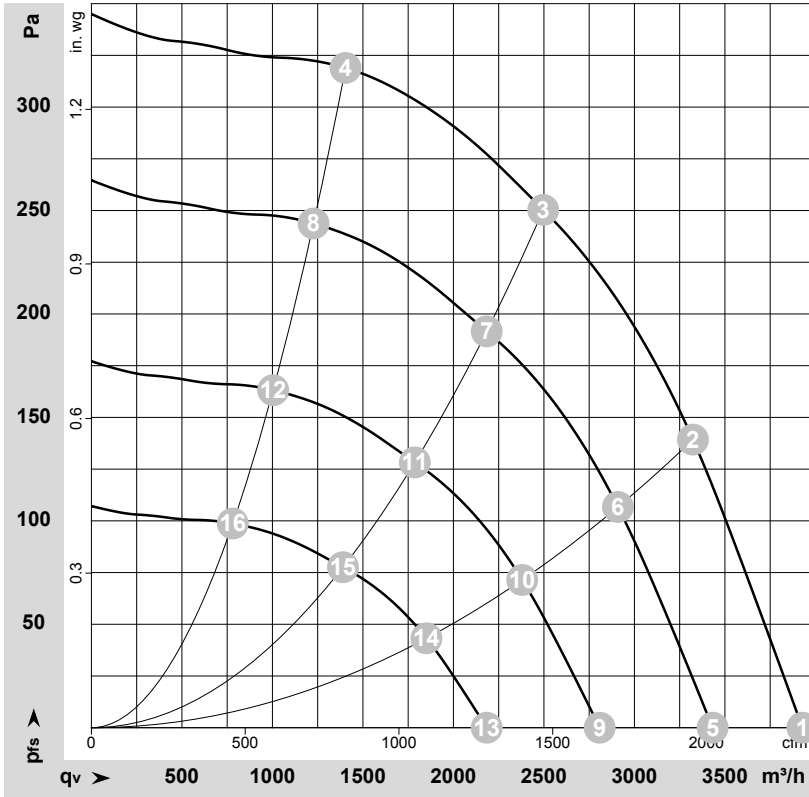

$\rho = 1.15 \text{ kg/m}^3 \pm 2 \%$

Measurement: LU-151921-1

Air performance measured according to ISO 5801 installation category A. For detailed information on the measurement setup, contact ebmpapst. Intake sound level: Sound power level according to ISO 13347 / sound pressure level measured at 1 m distance from fan axis. The values given are valid under the specified measuring conditions and may vary due to conditions of installation. For deviations from the standard configuration, the parameters have to be checked on the installed unit.

Measured values

	Wired	U	f	n	P _{ed}	I	LpA _{in}	LwA _{in}	q _v	P _{fs}	q _v	P _{fs}
		V	Hz	min ⁻¹	W	A	dB(A)	dB(A)	m ³ /h	Pa	cfm	in. wg
1	1~	230	50	1250	234	1.03	71	78	3930	0	2310	0.00
2	1~	230	50	1250	296	1.30	67	73	3325	140	1955	0.56
3	1~	230	50	1250	320	1.40	59	67	2495	250	1470	1.00
4	1~	230	50	1250	262	1.15	60	67	1405	320	825	1.28
5	1~	230	50	1100	156	0.69	67	74	3430	0	2020	0.00
6	1~	230	50	1100	199	0.87	63	69	2910	108	1710	0.43
7	1~	230	50	1100	210	0.92	56	63	2185	192	1285	0.77
8	1~	230	50	1100	175	0.77	56	64	1225	244	720	0.98
9	1~	230	50	900	86	0.38	62	69	2810	0	1655	0.00
10	1~	230	50	900	109	0.48	58	64	2380	72	1400	0.29
11	1~	230	50	900	115	0.51	51	58	1785	128	1050	0.51
12	1~	230	50	900	96	0.42	51	59	1005	163	590	0.65
13	1~	230	50	700	40	0.18	56	63	2185	0	1285	0.00
14	1~	230	50	700	51	0.22	52	58	1850	44	1090	0.18
15	1~	230	50	700	54	0.24	44	52	1390	78	820	0.31
16	1~	230	50	700	45	0.20	45	52	780	99	460	0.40

Wired = Wiring · U = Voltage · f = Frequency · n = Speed (rpm) · P_{ed} = Power consumption · I = Current draw · LpA_{in} = Sound pressure level intake side · LwA_{in} = Sound power level intake side
 q_v = Air flow · P_{fs} = Pressure increase

