

R3G400-PA41-13 ebmpapst Datasheet

sales@fansco.com

www.fansco.com

Limited partnership · Headquarters Mulfingen

Amtsgericht (court of registration) Stuttgart · HRA 590344

General partner Elektrobau Mulfingen GmbH · Headquarters Mulfingen

Amtsgericht (court of registration) Stuttgart · HRB 590142

Nominal data

Type	R3G400-PA41-13	
Motor	M3G150-FF	
Phase		3~
Nominal voltage	VAC	200
Nominal voltage range	VAC	200 .. 240
Frequency	Hz	50/60
Method of obtaining data		ml
Status		prelim.
Speed (rpm)	min ⁻¹	2800
Power consumption	W	3650
Current draw	A	11
Min. ambient temperature	°C	-40
Max. ambient temperature	°C	40

ml = Max. load · me = Max. efficiency · fa = Free air · cs = Customer specification · ce = Customer equipment
Subject to change

Data according to Commission Regulation (EU) 327/2011

		Actual	Req. 2015			
01 Overall efficiency η_{es}	%	63.7	57.4	09 Power consumption P_{ed}	kW	3.64
02 Measurement category		A		09 Air flow q_v	m ³ /h	5760
03 Efficiency category		Static		09 Pressure increase p_{fs}	Pa	1393
04 Efficiency grade N		68.3	62	10 Speed (rpm) n	min ⁻¹	2790
05 Variable speed drive		Yes		11 Specific ratio [*]		1.01

Data obtained at optimum efficiency level.

The ErP data is determined using a motor-impeller combination in a standardized measurement setup.

^{*} Specific ratio = $1 + p_{fs} / 100\,000\text{ Pa}$

LU-202611



Technical description

Weight	19.2 kg
Size	400 mm
Motor size	150
Rotor surface	Painted black
Electronics housing material	Die-cast aluminum
Impeller material	Sheet aluminum
Number of blades	5
Direction of rotation	Clockwise, viewed toward rotor
Degree of protection	IP55
Insulation class	"F"
Moisture (F) / Environmental (H) protection class	H1
Ambient temperature note	Occasional start-up at temperatures between -40°C and -25°C is permitted. For continuous operation at ambient temperatures below -25°C (such as refrigeration applications), use must be made of a fan design with special low-temperature bearings.
Max. permitted ambient temp. for motor (transport/storage)	+80 °C
Min. permitted ambient temp. for motor (transport/storage)	-40 °C
Installation position	Shaft horizontal or rotor on bottom; rotor on top on request
Condensation drainage holes	On rotor side
Mode	S1
Motor bearing	Ball bearing
Technical features	<ul style="list-style-type: none"> - Operation and alarm display with LED - External 15-50 VDC input (parameterization) - Alarm relay - Integrated PI controller - Configurable inputs/outputs (I/O) - MODBUS V6.0 - Motor current limitation - RFID - ISO 15693 compatible - RS-485 MODBUS-RTU - Soft start - Voltage output 3.3-24 VDC, Pmax = 800 mW - Control interface with SELV potential safely disconnected from the mains - Thermal overload protection for electronics/motor - Line undervoltage / phase failure detection
Touch current according to IEC 60990 (measuring circuit Fig. 4, TN system)	<= 3.5 mA
Electrical hookup	Terminal box
Protection class	I (with customer connection of protective earth)
Conformity with standards	EN 61800-5-1; CE
Approval	CSA C22.2 No. 77 + CAN/CSA-E60730-1; EAC; UL 1004-7 + 60730-1

Accessory part

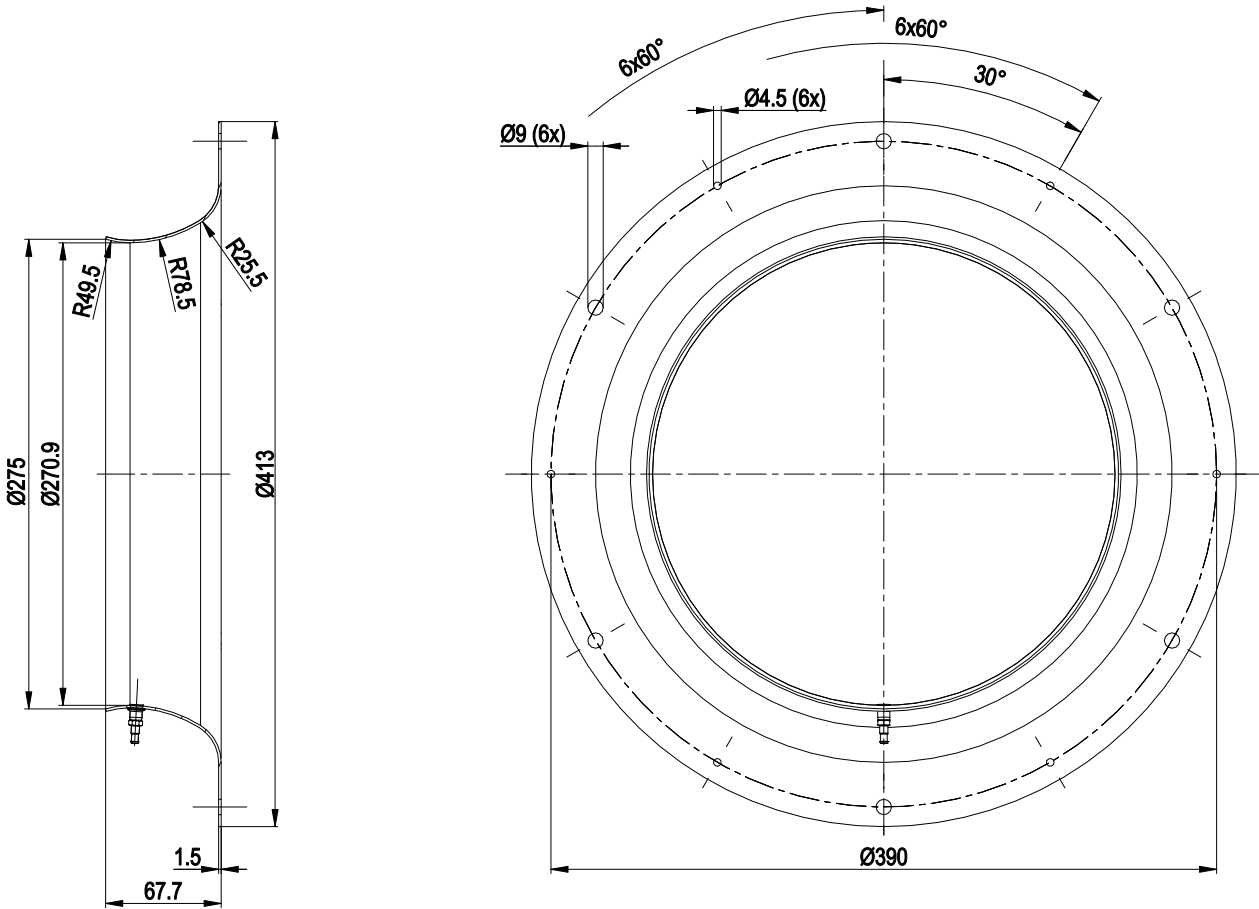

1 Inlet ring with pressure tap 40075-2-4013 (k-factor: 188) not included in scope of delivery

Connection diagram

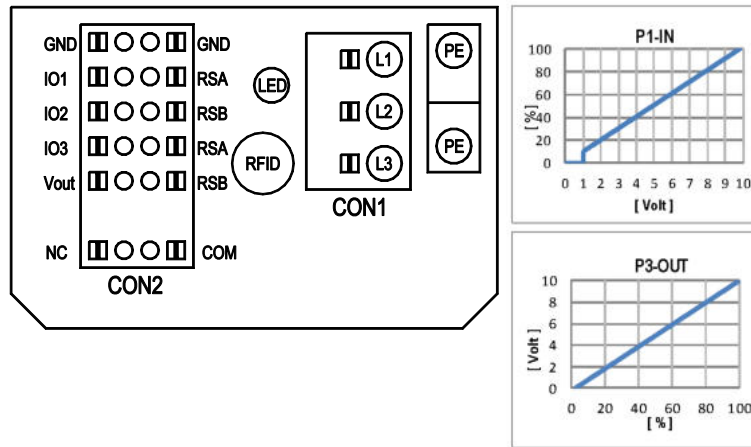

No.	Conn.	Designation	Function/assignment
	CON1	L1, L2, L3	Power supply, phase, see nameplate for voltage range
	PE	PE	Protective earth
	CON2	RSA	RS485 interface for MODBUS, RSA; SELV
	CON2	RSB	RS485 interface for MODBUS, RSB; SELV
	CON2	GND	Reference ground for control interface, SELV
	CON2	IO1	Function parameterizable (see "Optional interface functions" table) Factory setting: Digital input - high active, function: Disable input, SELV - inactive: Pin open or applied voltage < 1.5 VDC - active: applied voltage 3.5-50 VDC Reset function: Triggering of error reset on change of state from "enabled" to "disabled"
	CON2	IO2	Function parameterizable (see "Optional interface functions" table) Factory setting: Analog input 0-10 V / PWM, Ri=100 kΩ, function: Set value Characteristic curve parameterizable (see input characteristic curve P1-IN), SELV
	CON2	IO3	Function parameterizable (see "Optional interface functions" table) Factory setting: Analog output 0-10 V, max. 5 mA, function: Fan modulation level Characteristic curve parameterizable (see output characteristic curve P3-OUT), SELV
	CON2	Vout	Voltage output 3.3-24 VDC ±5%, Pmax=800 mW, voltage parameterizable Factory setting: 10 VDC short-circuit-proof, supply for external devices, SELV alternatively: 15-50 VDC input for parameterization via MODBUS without line voltage
	CON2	COM	Status relay, floating status contact, common connection, contact rating 250 VAC / 2 A (AC1) / min. 10 mA, reinforced insulation on supply side and on control interface side
	CON2	NC	Status relay, floating status contact, break for failure
		LED	green: status = good, ready for operation orange: status = warning red: status = failure
		P1-IN	Input characteristic curve
		P3-OUT	Output characteristic curve



Terminal/plug assignment

CON2	configurable IO mode	electrical specification	configurable IO functions: normal / inverse	MODBUS Register for IO mode configuration	source: set value	source: sensor value	switch: parameter set: #1 / #2	switch: control function: heating (pos.), cooling (neg.)	switch: direction of rotation: cw / ccw	switch: set value source	switch: fan enable / disable	signal: tach out	signal: diagnostics out	signal: fan modulation level %	signal: actual speed	signal: system modulation level %	signal: remote control output 0-10V	pulse input for auto-addressing	pulse output for auto-addressing
101	○ Din1 (active high), digital input	not active: pin open or applied voltage < 1.5VDC active: applied voltage 3.5-50VDC, SELV	D158 [0]																
	○ Ain1 0-10V/PWM: analog input	Ri=100k, characteristic curve parameterizable, f _{PWM} =1k..10kHz, SELV	D158 [2]																
	○ Tacho out (open collector output)	U _{max} =50VDC, I _{max} =20mA, SELV	D158 [5]																
	○ Diagnostics out (open collector output)	U _{max} =50VDC, I _{max} =20mA, SELV	D158 [6]																
102	○ Din2 (active high), digital input	not active: pin open or applied voltage < 1.5VDC active: applied voltage 3.5-50VDC, SELV	D159 [0]																
	○ Ain2 0-10V/PWM: analog input	Ri=100k, characteristic curve parameterizable, f _{PWM} =1k..10kHz, SELV	D159 [2]																
	○ Ain2 4-20mA: analog input	Ri=125R, characteristic curve parameterizable, SELV	D159 [3]																
103	○ Din3 (active high), digital input	not active: pin open or applied voltage < 1.5VDC active: applied voltage 3.5-50VDC, SELV	D15A [0]																
	○ Din3 (active low), digital input	not active: pin open or applied voltage < 1.5VDC active: applied voltage 3.5-50VDC, SELV	D15A [1]																
	○ PWMIn3: digital input	not active: pin open or applied voltage < 1.5VDC active: applied voltage < 1.5VDC, SELV 40Hz - 10kHz, characteristics parameterizable	D15A [7]																
	○ Aout3 0-10V: analog output	not active: pin open or applied voltage < 1.5VDC, SELV active: applied voltage < 1.5VDC, SELV function parameterizable, max. 5mA, max output frequency 300Hz, SELV	D15A [4]																
RSA RSB	○ Tacho out (pulses), analog output	0-10V max. 5mA, max output frequency 300Hz, SELV	D15A [5]																
	○ Diagnostics out (pulses)	0-10V max. 5mA, max output frequency 300Hz, SELV	D15A [6]																
	RS485 bus connection,	MODBUS RTU, specification V6.0, SELV																	
Vout	voltage output	voltage parameterizable 3.3...24VDC +/- 5.5%, P _{max} =800mW, short-circuit-proof, supply for external devices, SELV	D16E [..]																
	alternatively: input auxiliary power supply for parameterization via RS485/MODBUS RTU without line voltage	15...50VDC																	

○ configurable option

For further information and additional functions see EC Control Software, Fan-Set-App, or MODBUS Parameter Specification V6.0



Curves: Air performance 50 Hz

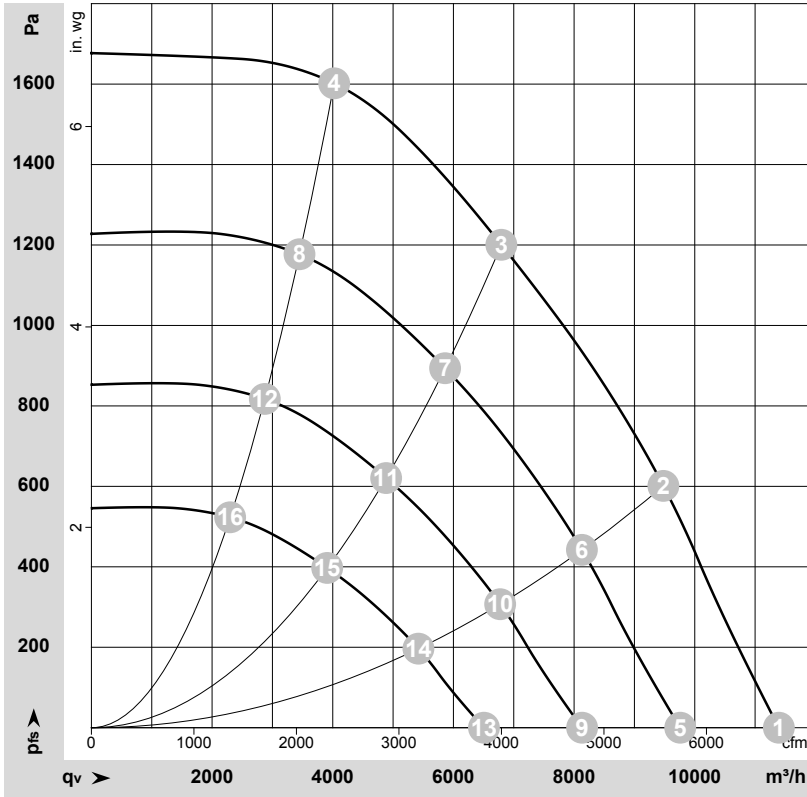

$\rho = 1.15 \text{ kg/m}^3 \pm 2 \%$

Measurement: LU-202611-1

Air performance measured according to ISO 5801 installation category A. For detailed information on the measurement setup, contact ebmpapst. Intake sound level: Sound power level according to ISO 13347 / sound pressure level measured at 1 m distance from fan axis. The values given are valid under the specified measuring conditions and may vary due to conditions of installation. For deviations from the standard configuration, the parameters have to be checked on the installed unit.

Measured values

	Wired	U	f	n	P _{ed}	I	LpA _{in}	LwA _{in}	LwA _{out}	q _v	p _{fs}	q _v	p _{fs}
		V	Hz	min ⁻¹	W	A	dB(A)	dB(A)	dB(A)	m ³ /h	Pa	cfm	in. wg
1	3~	200	50	2800	2277	6.92	92	99	100	11395	0	6705	0.00
2	3~	200	50	2800	3223	9.74	84	91	95	9480	600	5580	2.41
3	3~	200	50	2800	3650	11.00	78	85	92	6795	1200	4000	4.82
4	3~	200	50	2800	3411	10.29	82	89	94	4025	1600	2370	6.42
5	3~	200	50	2400	1431	4.35	88	95	96	9760	0	5745	0.00
6	3~	200	50	2400	2032	6.14	80	87	91	8130	447	4785	1.79
7	3~	200	50	2400	2367	7.14	74	81	88	5860	895	3450	3.59
8	3~	200	50	2400	2148	6.48	78	85	90	3450	1178	2030	4.73
9	3~	200	50	2000	828	2.51	83	91	92	8135	0	4785	0.00
10	3~	200	50	2000	1176	3.55	75	83	87	6775	310	3990	1.24
11	3~	200	50	2000	1370	4.13	70	77	83	4885	621	2875	2.49
12	3~	200	50	2000	1243	3.75	74	81	86	2875	818	1690	3.28
13	3~	200	50	1600	424	1.29	78	85	86	6505	0	3830	0.00
14	3~	200	50	1600	602	1.82	70	77	81	5420	199	3190	0.80
15	3~	200	50	1600	701	2.12	64	71	78	3910	398	2300	1.60
16	3~	200	50	1600	636	1.92	68	75	80	2300	523	1355	2.10

Wired = Wiring · U = Voltage · f = Frequency · n = Speed (rpm) · P_{ed} = Power consumption · I = Current draw · LpA_{in} = Sound pressure level intake side · LwA_{in} = Sound power level intake side · LwA_{out} = Sound power level outlet side · q_v = Air flow · p_{fs} = Pressure increase

