

R3G400-FR11-H1 ebmpapst Datasheet

sales@fansco.com

www.fansco.com

Limited partnership · Headquarters Mulfingen

Amtsgericht (court of registration) Stuttgart · HRA 590344

General partner Elektrobau Mulfingen GmbH · Headquarters Mulfingen

Amtsgericht (court of registration) Stuttgart · HRB 590142

Nominal data

Type	R3G400-FR11-H1	
Motor	M3G084-DF	
Phase		1~
Nominal voltage	VAC	230
Nominal voltage range	VAC	200 .. 277
Frequency	Hz	50/60
Method of obtaining data		ml
Status		prelim.
Speed (rpm)	min ⁻¹	1500
Power consumption	W	500
Current draw	A	2.2
Min. ambient temperature	°C	-25
Max. ambient temperature	°C	50

ml = Max. load · me = Max. efficiency · fa = Free air · cs = Customer specification · ce = Customer equipment
Subject to change

Data according to Commission Regulation (EU) 327/2011 (EN 17166)

		Actual	Req. 2015			
01 Overall efficiency η_{es}	%	65.8	48.3	09 Power consumption P_{ed}	kW	0.49
02 Measurement category		A		09 Air flow q_v	m ³ /h	3365
03 Efficiency category		Static		09 Pressure increase p_{fs}	Pa	316
04 Efficiency grade N		79.5	62	10 Speed (rpm) n	min ⁻¹	1480
05 Variable speed drive		Yes		11 Specific ratio [*]		1.00

Data obtained at optimum efficiency level.

^{*} Specific ratio = $1 + p_{fs} / 100\,000\text{ Pa}$

LU-204963

The efficiency values displayed for achieving conformity with the Ecodesign Regulation EU 327/2011 has been reached with defined air duct components (e.g. inlet rings).

The dimensions must be requested from ebm-papst. If other air conduction geometries are used on the installation side, the ebm-papst evaluation loses its validity/the conformity must be confirmed again.

The product does not fall within the scope of Regulation (EU) 2019/1781 due to the exception specified in Article 2 (2a) (motors completely integrated into a product).



Technical description

Size	400 mm
Motor size	84
Rotor surface	Painted black
Electronics housing material	Die-cast aluminum
Impeller material	PP plastic
Number of blades	6
Direction of rotation	Clockwise, viewed toward rotor
Degree of protection	IP55
Insulation class	"F"
Moisture (F) / Environmental (H) protection class	H1
Max. permitted ambient temp. for motor (transport/storage)	+80 °C
Min. permitted ambient temp. for motor (transport/storage)	-40 °C
Installation position	Shaft horizontal or rotor on bottom; rotor on top on request
Condensation drainage holes	On rotor side
Mode	S1
Motor bearing	Ball bearing
Technical features	<ul style="list-style-type: none"> - Output 10 VDC, max. 10 mA - Operation and alarm display - Alarm relay - Integrated PID controller - Power limiter - Motor current limitation - PFC, active - RS-485 MODBUS-RTU - Soft start - Control input 0-10 VDC / PWM - Control interface with SELV potential safely disconnected from the mains - Thermal overload protection for electronics/motor - Line undervoltage / phase failure detection
Touch current according to IEC 60990 (measuring circuit Fig. 4, TN system)	<= 3.5 mA
Motor protection	Thermal overload protector (TOP) internally connected
With cable	Variable
Protection class assignment	<p>I; If a protective earth is connected by the customer</p> <p>This component for installation may have several local protection classes. This information relates to this component's basic design.</p> <p>The final protection class is based on the component's intended installation and connection.</p>
Conformity with standards	EN 61800-5-1; EN 60335-1; CE
Approval	UL 1004-7 + 60730-1; CSA C22.2 No. 77 + CAN/CSA-E60730-1

Product drawing

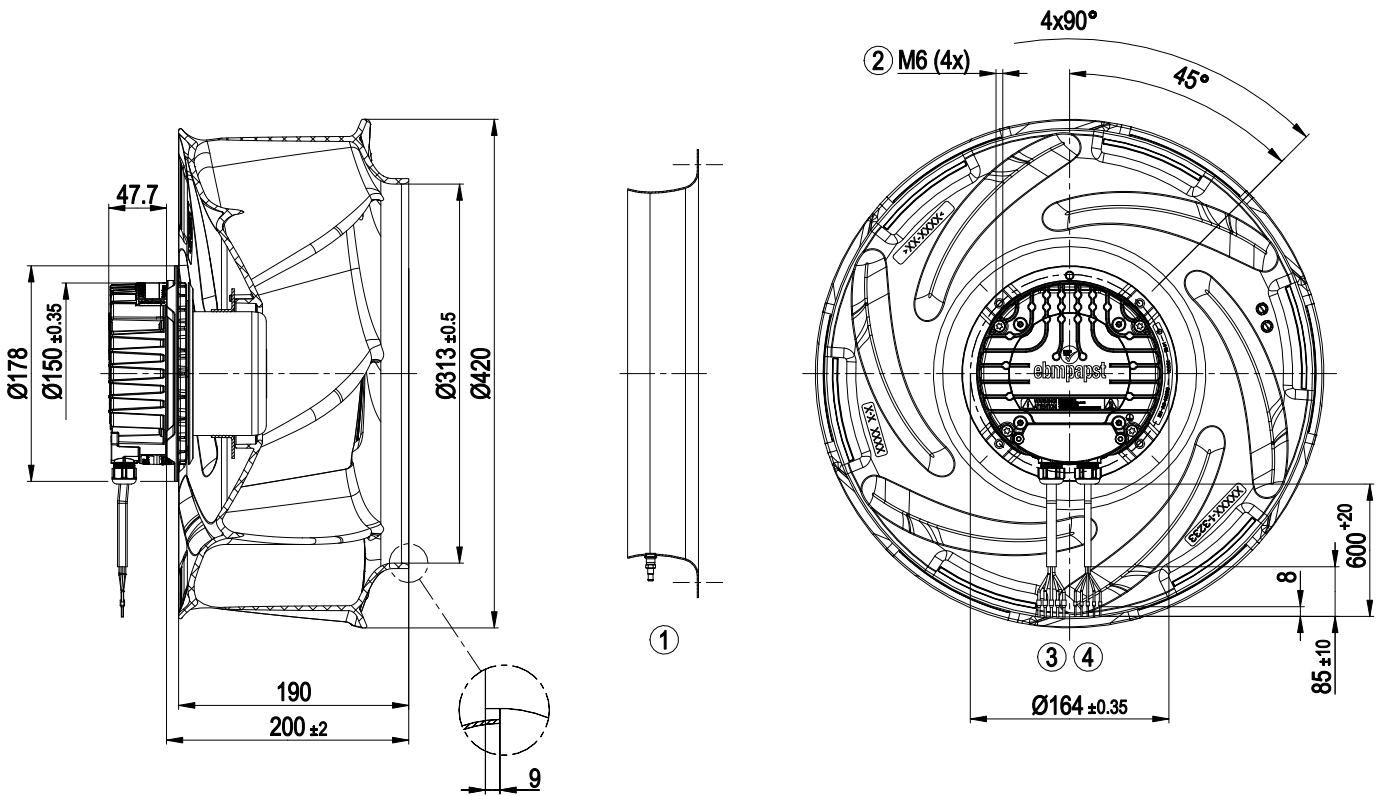

1	Accessory part: Inlet ring 40355-2-4013 with pressure tap (k-factor: 235) (not included in scope of delivery)
2	Max. clearance for screw 16 mm
3	Cable PVC AWG18 5x wire-end ferrule
4	Cable PVC AWG22 5x wire-end ferrule



Accessory part

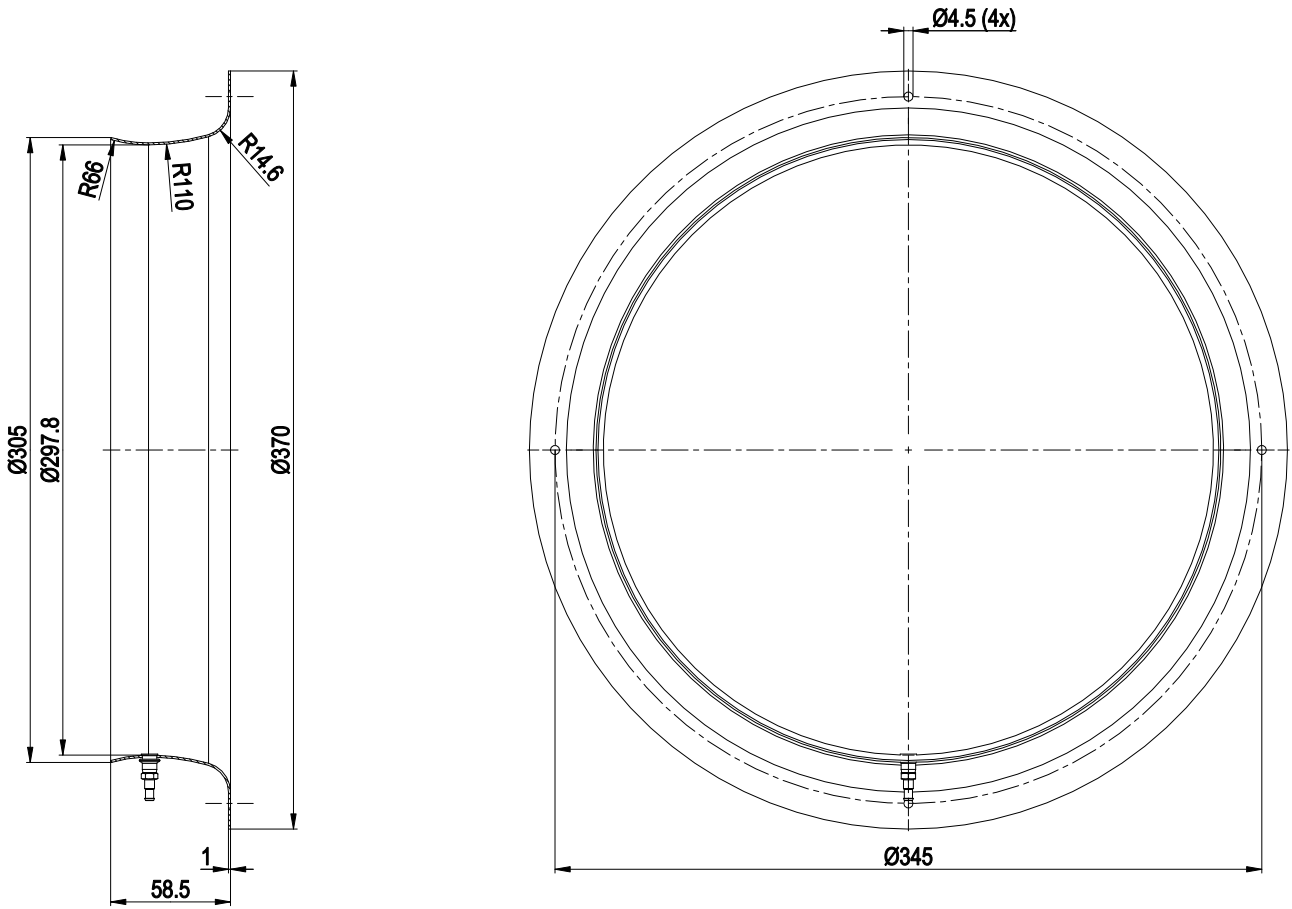

Inlet ring 40355-2-4013 with pressure tap (k-factor: 235)

Connection diagram



No.	Conn.	Designation	Color	Function/assignment
1	1, 2	PE	green/yellow	Protective earth
1	3	N	blue	Power supply, neutral conductor, 50/60 Hz
1	5	L	black	Power supply, phase, 50/60 Hz
1	6	NC	white 1	Status relay, floating status contact; break for failure, contact rating 250 VAC / 2A (AC1) / min. 10 mA, basic insulation on supply side and reinforced insulation on control interface side
1	7	COM	white 2	Status relay, floating status contact; common connection, contact rating 250 VAC / 2A (AC1) / min. 10 mA, basic insulation on supply side and reinforced insulation on control interface side
2	8	0-10V	yellow	Analog input (set value); 0-10 V; Ri = 100 kΩ; adjustable curve
2	10	RSB	brown	RS485 interface for MODBUS, RSB
2	11	RSA	white	RS485 interface for MODBUS, RSA
2	12	GND	blue	Reference ground for control interface, SELV
2	13	+10V	red	Fixed voltage output 10 VDC, +10 V ±3%; max. 10 mA; short-circuit-proof; power supply for external devices (e.g. pot)



Curves: Air performance 50 Hz

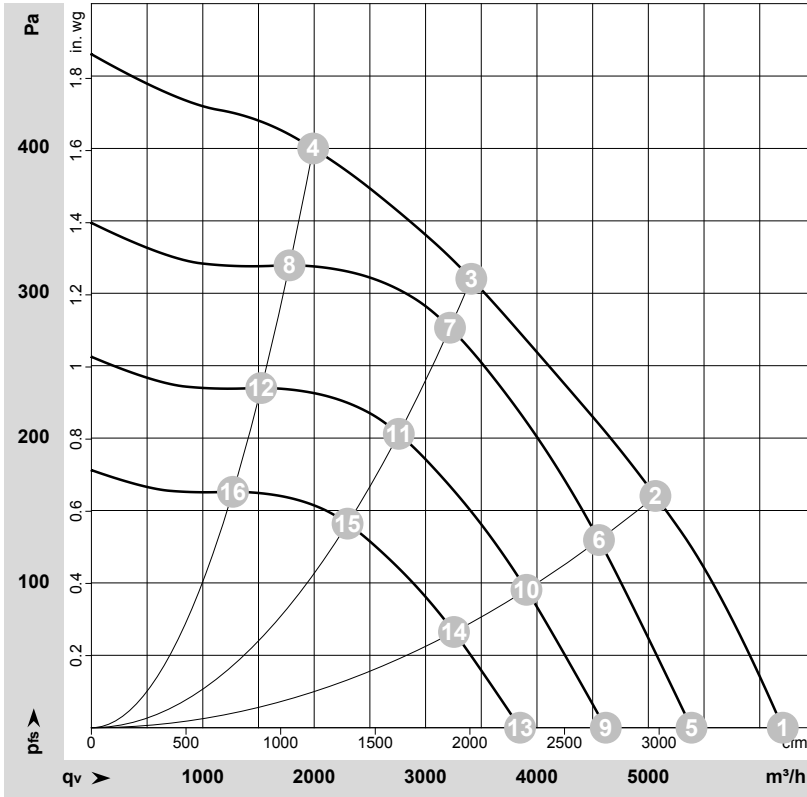

$\rho = 1.15 \text{ kg/m}^3 \pm 2 \%$

Measurement: LU-204963-1

Air performance measured according to ISO 5801 installation category A. For detailed information on the measurement setup, contact ebmpapst. Intake sound level: Sound power level according to ISO 13347 / sound pressure level measured at 1 m distance from fan axis. The values given are valid under the specified measuring conditions and may vary due to conditions of installation. For deviations from the standard configuration, the parameters have to be checked on the installed unit.

Measured values

	Wired	U	f	n	P _{ed}	I	LpA _{in}	LwA _{in}	LwA _{out}	q _v	p _{fs}	q _v	p _{fs}
		V	Hz	min ⁻¹	W	A	dB(A)	dB(A)	dB(A)	m ³ /h	Pa	cfm	in. wg
1	1~	230	50	1610	376	1.65	72	77	80	6205	0	3655	0.00
2	1~	230	50	1555	489	2.14	65	74	79	5065	160	2980	0.64
3	1~	230	50	1500	500	2.20	58	66	71	3410	310	2010	1.24
4	1~	230	50	1565	500	2.20	66	74	77	1990	400	1170	1.61
5	1~	230	50	1400	246	1.08	68	73	76	5390	0	3170	0.00
6	1~	230	50	1400	356	1.56	63	71	77	4555	130	2680	0.52
7	1~	230	50	1400	420	1.84	57	65	70	3220	279	1895	1.12
8	1~	230	50	1400	354	1.55	63	71	75	1780	320	1045	1.28
9	1~	230	50	1200	155	0.68	64	69	72	4620	0	2720	0.00
10	1~	230	50	1200	224	0.98	59	67	73	3905	96	2300	0.39
11	1~	230	50	1200	265	1.16	53	61	66	2760	205	1625	0.82
12	1~	230	50	1200	223	0.97	59	67	71	1525	235	900	0.94
13	1~	230	50	1000	90	0.39	60	65	68	3850	0	2265	0.00
14	1~	230	50	1000	130	0.57	54	63	68	3255	66	1915	0.26
15	1~	230	50	1000	153	0.67	48	56	61	2300	142	1355	0.57
16	1~	230	50	1000	129	0.56	55	63	66	1270	163	750	0.65

Wired = Wiring · U = Voltage · f = Frequency · n = Speed (rpm) · P_{ed} = Power consumption · I = Current draw · LpA_{in} = Sound pressure level intake side · LwA_{in} = Sound power level intake side
 LwA_{out} = Sound power level outlet side · q_v = Air flow · p_{fs} = Pressure increase

