

R3G400-AS12-03

# EC centrifugal fan

backward-curved, single-intake



R3G400-AS12-03 ebmpapst Datasheet

sales@fansco.com

www.fansco.com

Limited partnership · Headquarters Muldingen  
Amtsgericht (court of registration) Stuttgart · HRA 590344

General partner Elektrobau Muldingen GmbH · Headquarters Muldingen  
Amtsgericht (court of registration) Stuttgart · HRB 590142



## Nominal data

Type	R3G400-AS12-03	
Motor	M3G150-FF	
Phase		3~
Nominal voltage	VAC	400
Nominal voltage range	VAC	380 .. 480
Frequency	Hz	50/60
Method of obtaining data		ml
Status		prelim.
Speed (rpm)	min <sup>-1</sup>	2590
Power consumption	W	2950
Current draw	A	4.8
Min. ambient temperature	°C	-25
Max. ambient temperature	°C	40

ml = Max. load · me = Max. efficiency · fa = Free air · cs = Customer specification · ce = Customer equipment  
Subject to change

## Data according to ErP Directive

		Actual	Req. 2015			
01 Overall efficiency $\eta_{es}$	%	57.3	56.2	09 Power consumption $P_{ed}$	kW	2.8
02 Measurement category		A		09 Air flow $q_v$	m <sup>3</sup> /h	4870
03 Efficiency category		Static		09 Pressure increase $p_{fs}$	Pa	1124
04 Efficiency grade N		63.1	62	10 Speed (rpm) n	min <sup>-1</sup>	2590
05 Variable speed drive		Yes		11 Specific ratio <sup>*</sup>		1.01

Data obtained at optimum efficiency level.  
The ErP data is determined using a motor-impeller combination in a standardized measurement setup.

<sup>\*</sup> Specific ratio =  $1 + p_{fs} / 100\,000\text{ Pa}$

LU-71822



## Technical description

Weight	20 kg
Fan size	400 mm
Rotor surface	Painted black
Electronics housing material	Die-cast aluminum
Impeller material	Sheet aluminum
Number of blades	7
Direction of rotation	Clockwise, viewed toward rotor
Degree of protection	IP55
Insulation class	"F"
Moisture (F) / Environmental (H) protection class	F4-1
Max. permitted ambient temp. for motor (transport/storage)	+80 °C
Min. permitted ambient temp. for motor (transport/storage)	-40 °C
Installation position	Shaft horizontal or rotor on bottom; rotor on top on request
Condensation drainage holes	On rotor side
Mode	S1
Motor bearing	Ball bearing
Technical features	<ul style="list-style-type: none"> <li>- Output 10 VDC, max. 10 mA</li> <li>- Output 20 VDC, max. 50 mA</li> <li>- Output for slave 0-10 V</li> <li>- Input for sensor 0-10 V or 4-20 mA</li> <li>- Alarm relay</li> <li>- Integrated PID controller</li> <li>- Motor current limitation</li> <li>- PFC, passive</li> <li>- RS-485 ebmBUS</li> <li>- Soft start</li> <li>- Control input 0-10 VDC / PWM</li> <li>- Control interface with SELV potential safely disconnected from supply</li> <li>- Thermal overload protection for electronics/motor</li> <li>- Line undervoltage / phase failure detection</li> </ul>
EMC immunity to interference	According to EN 61000-6-2 (industrial environment)
EMC interference emission	According to EN 61000-6-3 (household environment)
Touch current according to IEC 60990 (measuring circuit Fig. 4, TN system)	<= 3.5 mA
Electrical hookup	Via terminal box
Motor protection	Reverse polarity and locked-rotor protection
Protection class	I (with customer connection of protective earth)
Conformity with standards	EN 61800-5-1; CE
Approval	UL 1004-1; VDE; CSA C22.2 No. 77; EAC

Product drawing

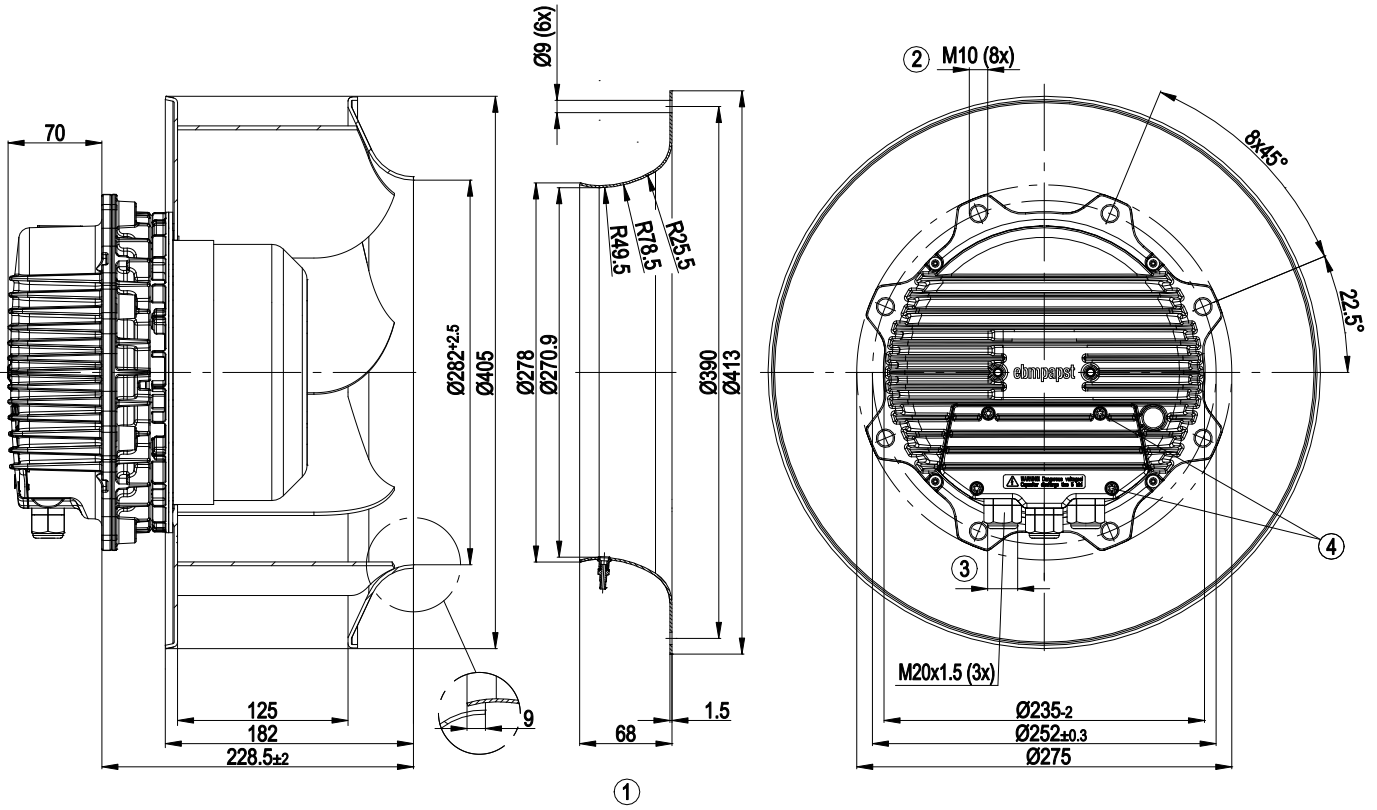

1	Accessory part: Inlet ring 40075-2-4013 with pressure tap not included in scope of delivery
2	Max. clearance for screw 25 mm
3	Cable diameter min. 4 mm, max. 10 mm; tightening torque 4±0.6 Nm
4	Tightening torque 3.5 ± 0.5 Nm



## Connection diagram

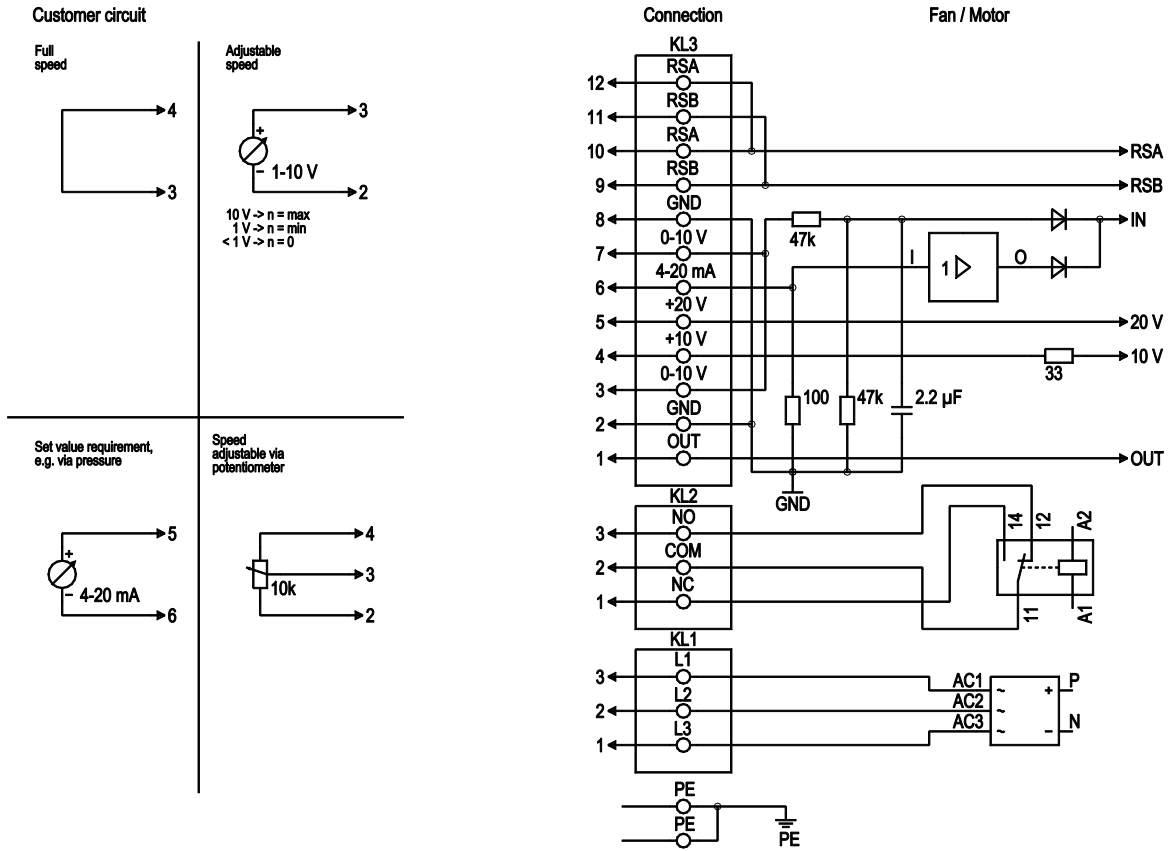

No.	Conn.	Designation	Function/assignment
PE		PE	Protective earth terminal
KL1	1, 2, 3	L1, L2, L3	Power supply 50/60 Hz
KL2	1	NC	Floating status contact, break for failure
KL2	2	COM	floating status contact, changeover contact, common connection (2 A, max. 250 VAC, min. 10 mA, AC1)
KL2	3	NO	Floating status contact, make for failure
KL3	1	OUT	Analog output, 0-10 VDC, max. 3 mA, SELV, output of current motor modulation level: 1 V corresponds to 10 % modulation level. 10 V corresponds to 100 % modulation level.
KL3	2, 8	GND	Reference ground for control interface, SELV
KL3	3, 7	0-10 V	Use control / current sensor value input 0-10 VDC, impedance 100 kΩ only as alternative to 4-20 mA input, SELV
KL3	4	+10 V	Voltage output 10 VDC (±3 %), max. 10 mA, power supply for external devices (e.g. potentiometer), SELV
KL3	5	+20 V	Voltage output 20 VDC (+25% / -10%), max. 50 mA, power supply for external devices (e.g. sensors); SELV
KL3	6	4-20 mA	Use control / current sensor value input 4-20 mA, impedance 100 Ω only as alternative to 0-10 V input, SELV
KL3	9, 11	RSB	RS485 interface for ebmBUS, RSB, SELV
KL3	10, 12	RSA	RS485 interface for ebmBUS, RSA, SELV



## Curves: Air performance 50 Hz

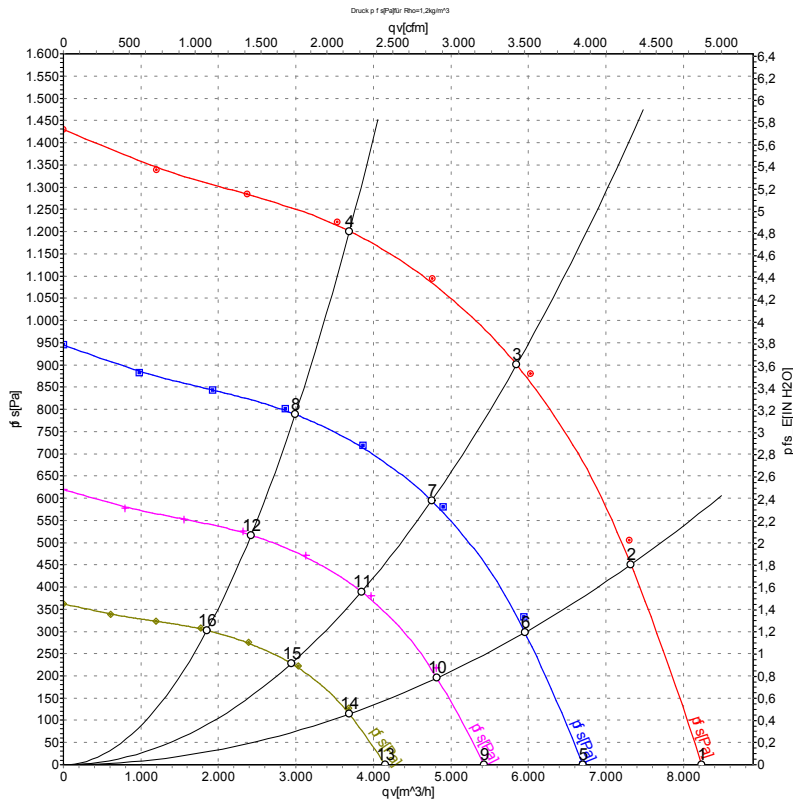

Measurement: LU-101274-1

Air performance measured according to ISO 5801 installation category A. For detailed information on the measurement setup, contact ebmpapst. Intake sound level: Sound power level according to ISO 13347 / sound pressure level measured at 1 m distance from fan axis. The values given are valid under the specified measuring conditions and may vary due to conditions of installation. For deviations from the standard configuration, the parameters have to be checked on the installed unit.

## Measured values

	U	f	n	P <sub>ed</sub>	I	LpA <sub>in</sub>	LwA <sub>in</sub>	LwA <sub>out</sub>	qv	P <sub>fs</sub>	qv	P <sub>fs</sub>
	V	Hz	min <sup>-1</sup>	W	A	dB(A)	dB(A)	dB(A)	m <sup>3</sup> /h	Pa	CFM	inH2O
1	400	50	2590	2075	3.18	85	94	100	8235	0	4850	0.00
2	400	50	2590	2594	3.97	83	92	99	7325	500	4310	2.01
3	400	50	2590	2800	4.30	81	89	97	5850	900	3440	3.61
4	400	50	2590	2456	3.76	82	90	98	3690	1200	2175	4.82
5	400	50	2100	1119	1.72	81	89	96	6705	0	3945	0.00
6	400	50	2100	1394	2.13	79	87	94	5955	328	3505	1.32
7	400	50	2100	1491	2.29	76	84	92	4750	601	2795	2.41
8	400	50	2100	1307	2.00	77	86	93	2990	791	1760	3.18
9	400	50	1700	594	0.91	76	84	91	5425	0	3195	0.00
10	400	50	1700	740	1.13	74	83	90	4820	215	2835	0.86
11	400	50	1700	791	1.21	72	80	88	3845	394	2265	1.58
12	400	50	1700	693	1.06	73	81	88	2420	518	1425	2.08
13	400	50	1300	265	0.41	71	79	85	4150	0	2445	0.00
14	400	50	1300	331	0.51	69	77	84	3685	126	2170	0.51
15	400	50	1300	354	0.54	66	74	82	2940	230	1730	0.92
16	400	50	1300	310	0.48	67	75	83	1850	303	1090	1.22

U = Power supply · f = Frequency · n = Speed (rpm) · P<sub>ed</sub> = Power consumption · I = Current draw · LpA<sub>in</sub> = Sound pressure level intake side · LwA<sub>in</sub> = Sound power level intake side  
 LwA<sub>out</sub> = Sound power level outlet side · qv = Air flow · P<sub>fs</sub> = Pressure increase

