

R3G400-AM56-21

EC centrifugal fan

backward-curved, single-intake



R3G400-AM56-21 ebmpapst Datasheet FansCo

sales@fansco.com

www.fansco.com

Nominal data

Type	R3G400-AM56-21	
Motor	M3G112-EA	
Phase		1~
Nominal voltage	VAC	230
Nominal voltage range	VAC	200 .. 277
Frequency	Hz	50/60
Method of obtaining data		ml
Speed (rpm)	min ⁻¹	1720
Power consumption	W	775
Current draw	A	3.5
Min. ambient temperature	°C	-25
Max. ambient temperature	°C	40

ml = Max. load · me = Max. efficiency · fa = Free air · cs = Customer specification · ce = Customer equipment
Subject to change

Data according to ErP Directive

		Actual	Req. 2015
01 Overall efficiency η_{es}	%	58.1	50.3
02 Measurement category		A	
03 Efficiency category		Static	
04 Efficiency grade N		69.8	62
05 Variable speed drive		Yes	

Data obtained at optimum efficiency level.
The ErP data is determined using a motor-impeller combination in a standardized measurement setup.

09 Power consumption P_{ed}	kW	0.77
09 Air flow q_v	m ³ /h	3005
09 Pressure increase p_{fs}	Pa	494
10 Speed (rpm) n	min ⁻¹	1720
11 Specific ratio*		1.01

* Specific ratio = $1 + p_{fs} / 100\,000\text{ Pa}$

LU-109926



Technical description

Weight	8.4 kg
Fan size	400 mm
Rotor surface	Painted black
Electronics housing material	Die-cast aluminum
Impeller material	Sheet aluminum
Number of blades	6
Direction of rotation	Clockwise, viewed toward rotor
Degree of protection	IP54
Insulation class	"B"
Moisture (F) / Environmental (H) protection class	F4-1
Max. permitted ambient temp. for motor (transport/storage)	+80 °C
Min. permitted ambient temp. for motor (transport/storage)	-40 °C
Installation position	Any
Condensation drainage holes	On rotor and stator sides
Mode	S1
Motor bearing	Ball bearing
Technical features	<ul style="list-style-type: none"> - Output 10 VDC, max. 10 mA - Output 20 VDC, max. 50 mA - Output for slave 0-10 V - Input for sensor 0-10 V or 4-20 mA - Alarm relay - Integrated PID controller - Motor current limitation - PFC, active - RS-485 ebmBUS - Soft start - Control input 0-10 VDC / PWM - Control interface with SELV potential safely disconnected from supply - Thermal overload protection for electronics/motor - Line undervoltage / phase failure detection
EMC immunity to interference	According to EN 61000-6-2 (industrial environment)
EMC circuit feedback	According to EN 61000-3-2/3
EMC interference emission	According to EN 55022 (Class A, industrial environment)
Touch current according to IEC 60990 (measuring circuit Fig. 4, TN system)	<= 3.5 mA
Electrical hookup	Via terminal box
Motor protection	Thermal overload protector (TOP) internally connected
Protection class	I (with customer connection of protective earth)
Conformity with standards	EN 61800-5-1; CE

Product drawing

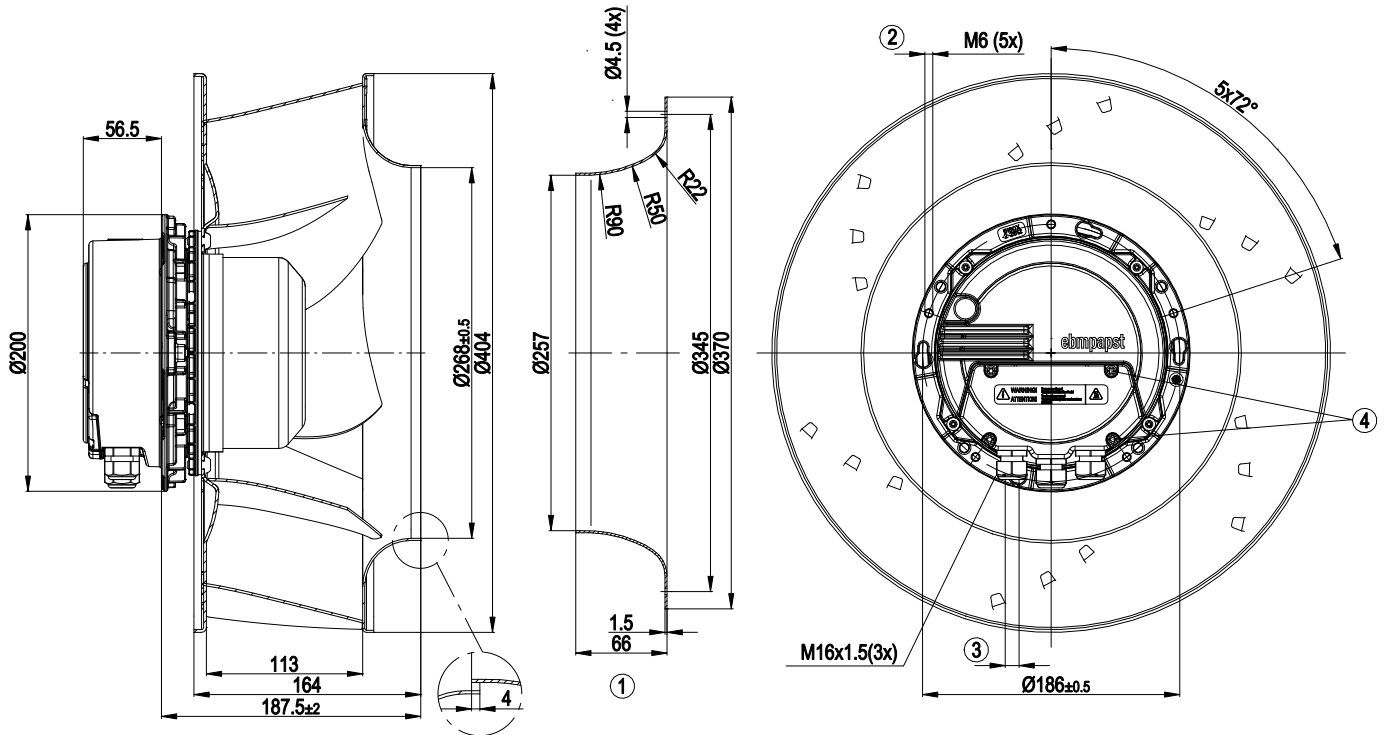

1	Accessory part: Inlet ring 54476-2-4013 not included in scope of delivery.
2	Max. clearance for screw 16 mm
3	Cable diameter min. 4 mm; max. 10 mm, tightening torque 2.5 ± 0.4 Nm
4	Tightening torque 3.5 ± 0.5 Nm



Connection diagram

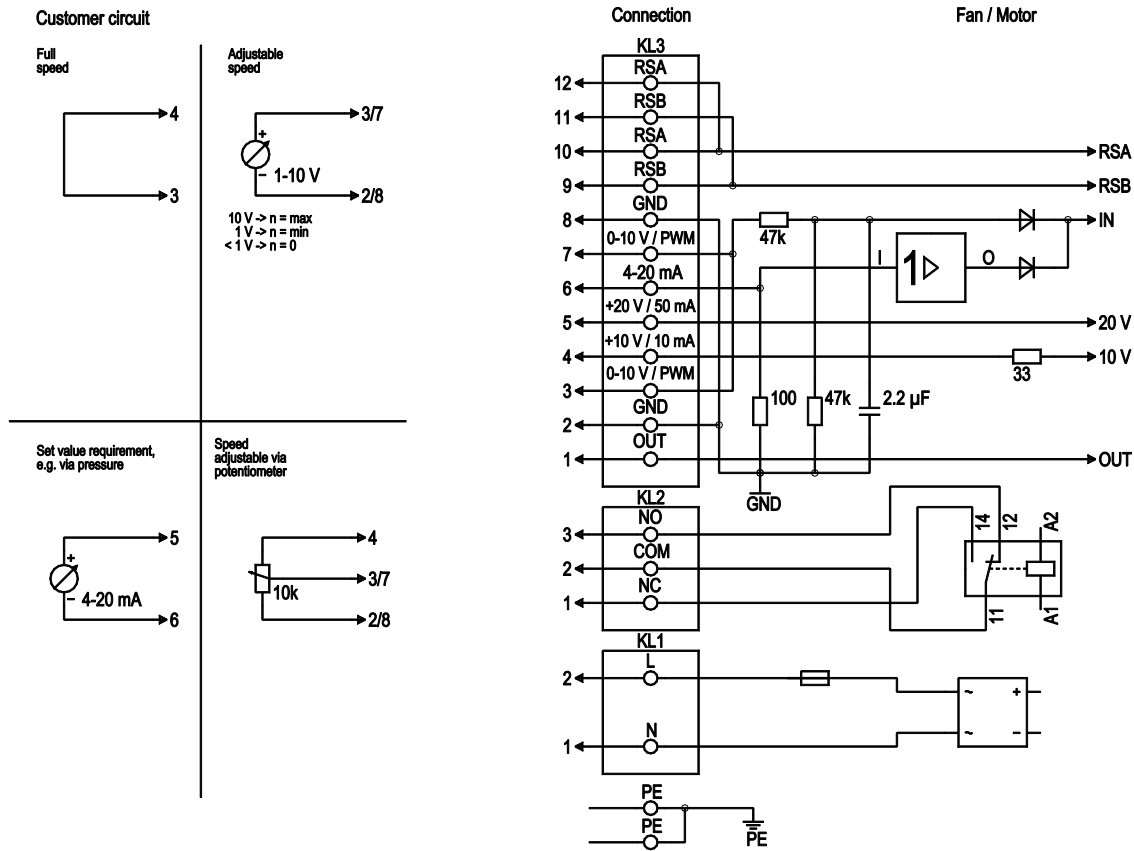

No.	Conn.	Designation	Function/assignment
PE		PE	Protective earth terminal
KL1	1, 2	N, L	Power supply 50/60 Hz
KL2	1	NC	Floating status contact, break for failure
KL2	2	COM	Floating status contact, changeover contact, common connection (2 A, max. 250 VAC, min. 10 mA, AC1)
KL2	3	NO	Floating status contact, make for failure
KL3	1	OUT	Analog output, 0-10 VDC, max. 3 mA, SELV, output of current motor modulation level: 1 V corresponds to 10% modulation level. 10 V corresponds to 100% modulation level.
KL3	2, 8	GND	Reference ground for control interface, SELV
KL3	3, 7	0-10 V	Use control / current sensor value input 0-10 VDC, impedance 100 kΩ only as alternative to 4-20 mA input, SELV
KL3	4	+10 V	Voltage output 10 VDC (±3 %), max. 10 mA, power supply for external devices (e.g. potentiometer), SELV
KL3	5	+20 V	Voltage output 20 VDC (+25% / -10%), max. 50 mA, power supply for external devices (e.g. sensors); SELV
KL3	6	4-20 mA	Use control / current sensor value input 4-20 mA, impedance 100 Ω only as alternative to 0-10 V input, SELV
KL3	9, 11	RSB	RS485 interface for ebmBUS, RSB, SELV
KL3	10, 12	RSA	RS485 interface for ebmBUS, RSA, SELV



Curves: Air performance 50 Hz

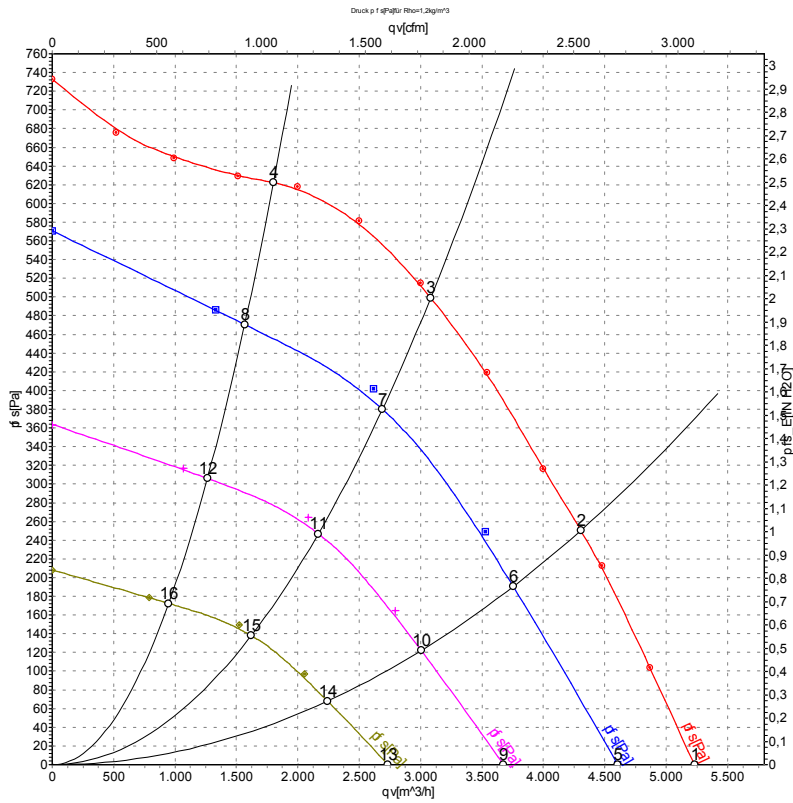

Measurement: LU-109926-1
 Measurement: LU-118303-1
 Measurement: LU-118304-1
 Measurement: LU-118305-1

Air performance measured according to ISO 5801 installation category A. For detailed information on the measurement setup, contact ebmpapst. Intake sound level: Sound power level according to ISO 13347 / sound pressure level measured at 1 m distance from fan axis. The values given are valid under the specified measuring conditions and may vary due to conditions of installation. For deviations from the standard configuration, the parameters have to be checked on the installed unit.

Measured values

	U	f	n	P _{ed}	I	LpA _{in}	LwA _{in}	LwA _{out}	qv	p _{fs}	qv	p _{fs}
	V	Hz	min ⁻¹	W	A	dB(A)	dB(A)	dB(A)	m ³ /h	Pa	CFM	inH2O
1	230	50	1720	568	2.58	77	83	89	5230	0	3080	0.00
2	230	50	1720	691	3.10	73	79	85	4305	250	2535	1.00
3	230	50	1720	775	3.50	67	73	79	3085	500	1815	2.01
4	230	50	1720	673	3.03	73	80	85	1805	625	1060	2.51
5	230	50	1500	364	1.69	73	79	85	4605	0	2710	0.00
6	230	50	1500	438	2.02	68	74	79	3755	196	2210	0.79
7	230	50	1500	495	2.27	64	71	76	2690	390	1585	1.57
8	230	50	1500	421	1.94	68	75	80	1565	471	920	1.89
9	230	50	1200	197	0.94	67	73	78	3675	0	2165	0.00
10	230	50	1200	230	1.08	62	68	73	3005	125	1770	0.50
11	230	50	1200	260	1.21	59	65	71	2170	253	1275	1.02
12	230	50	1200	218	1.03	62	68	73	1265	307	745	1.23
13	230	50	900	93	0.48	58	66	70	2735	0	1610	0.00
14	230	50	900	107	0.53	54	61	65	2245	70	1320	0.28
15	230	50	900	118	0.57	51	60	65	1620	140	955	0.56
16	230	50	900	102	0.50	53	61	67	950	172	560	0.69

U = Power supply · f = Frequency · n = Speed (rpm) · P_{ed} = Power consumption · I = Current draw · LpA_{in} = Sound pressure level intake side · LwA_{in} = Sound power level intake side
 LwA_{out} = Sound power level outlet side · qv = Air flow · p_{fs} = Pressure increase

