

R3G400-AK57-22 ebmpapst Datasheet

sales@fansco.com

www.fansco.com

Limited partnership · Headquarters Muldingen

Amtsgericht (court of registration) Stuttgart · HRA 590344

General partner Elektrobau Muldingen GmbH · Headquarters Muldingen

Amtsgericht (court of registration) Stuttgart · HRB 590142

Nominal data

| | | |
|--------------------------|-------------------|------------|
| Type | R3G400-AK57-22 | |
| Motor | M3G112-EA | |
| Phase | | 3~ |
| Nominal voltage | VAC | 200 |
| Nominal voltage range | VAC | 200 .. 240 |
| Frequency | Hz | 50/60 |
| Method of obtaining data | | ml |
| Speed (rpm) | min ⁻¹ | 1880 |
| Power consumption | W | 1000 |
| Current draw | A | 2.9 |
| Min. ambient temperature | °C | -25 |
| Max. ambient temperature | °C | 60 |

ml = Max. load · me = Max. efficiency · fa = Free air · cs = Customer specification · ce = Customer equipment
Subject to change



Technical description

| | |
|--|--|
| Weight | 9 kg |
| Fan size | 400 mm |
| Rotor surface | Painted black |
| Electronics housing material | Die-cast aluminum |
| Impeller material | Sheet aluminum |
| Number of blades | 6 |
| Direction of rotation | Clockwise, viewed toward rotor |
| Degree of protection | IP54 |
| Insulation class | "B" |
| Moisture (F) / Environmental (H) protection class | F4-1 |
| Max. permitted ambient temp. for motor (transport/storage) | + 80 °C |
| Min. permitted ambient temp. for motor (transport/storage) | - 40 °C |
| Installation position | Any |
| Condensation drainage holes | On rotor and stator sides |
| Mode | S1 |
| Motor bearing | Ball bearing |
| Technical features | <ul style="list-style-type: none"> - Output 10 VDC, max. 10 mA - Output 20 VDC, max. 50 mA - Output for slave 0-10 V - Input for sensor 0-10 V or 4-20 mA - Alarm relay - Integrated PID controller - Motor current limitation - PFC, passive - RS-485 ebmBUS - Soft start - Control input 0-10 VDC / PWM - Control interface with SELV potential safely disconnected from the mains - Thermal overload protection for electronics/motor - Line undervoltage / phase failure detection |
| Touch current according to IEC 60990 (measuring circuit Fig. 4, TN system) | <= 3.5 mA |
| Electrical hookup | Via terminal box |
| Motor protection | Thermal overload protector (TOP) internally connected |
| Protection class | I (with customer connection of protective earth) |
| Conformity with standards | EN 61800-5-1; CE |
| Approval | B; UL 1004-3 |

Product drawing

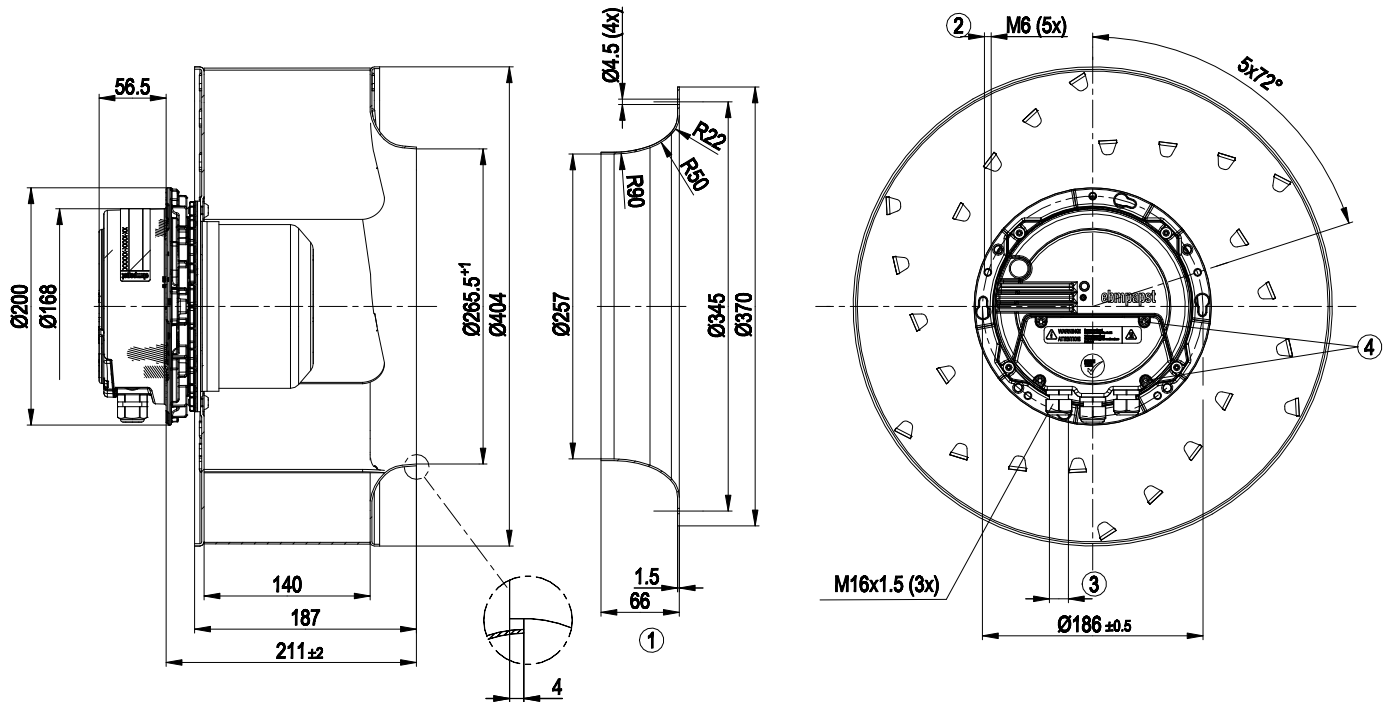

| | |
|---|---|
| 1 | Accessory part: inlet ring 54476-2-4013 not included in scope of delivery |
| 2 | Max. clearance for screw 16 mm |
| 3 | Cable diameter min. 4 mm, max. 10 mm; tightening torque 2.5 ± 0.4 Nm |
| 4 | Tightening torque 3.5 ± 0.5 Nm |



Connection diagram

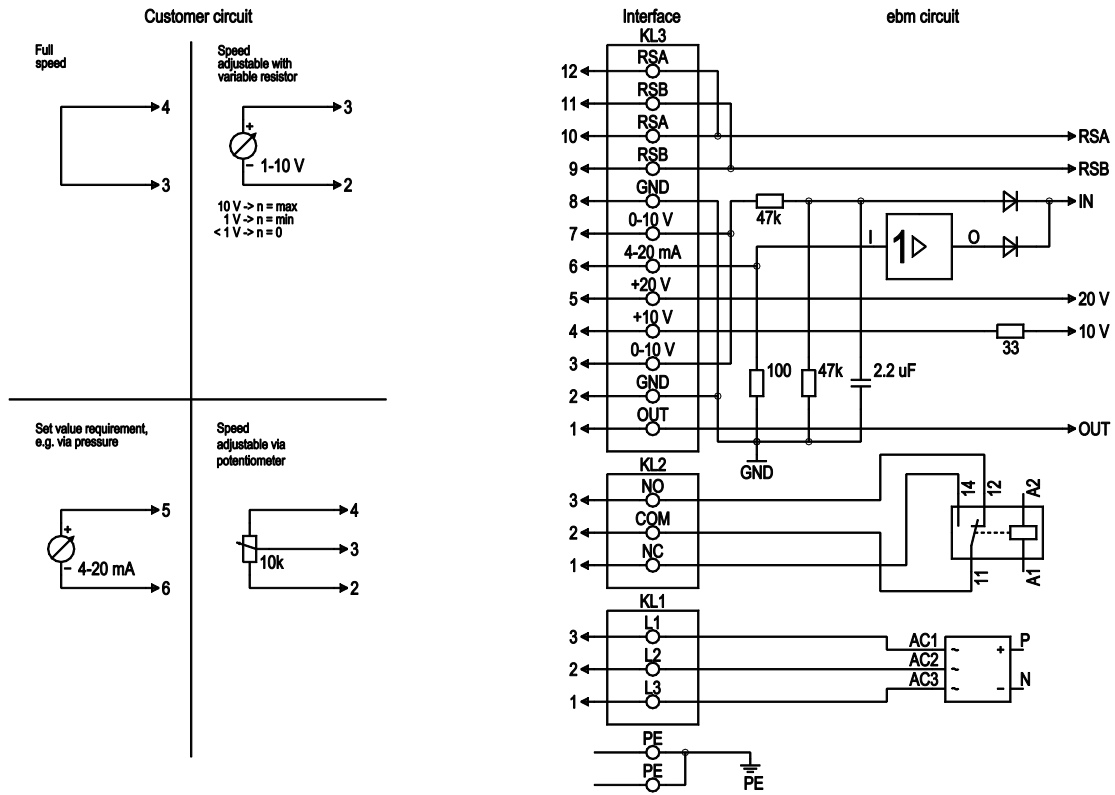

| No. | Conn. | Designation | Function/assignment |
|-----|---------|-------------|--|
| PE | | PE | Protective earth terminal |
| KL1 | 1, 2, 3 | L1, L2, L3 | Power supply 50/60 Hz |
| KL2 | 1 | NC | Floating status contact, break for failure |
| KL2 | 2 | COM | Floating status contact, changeover contact, common connection (2 A, max. 250 VAC, min. 10 mA, AC1) |
| KL2 | 3 | NO | Floating status contact, make for failure |
| KL3 | 1 | OUT | Tach output; 1 pulse/revolution, open collector; $R_i=680 \Omega$, |
| KL3 | 2, 8 | GND | Reference ground for control interface, SELV |
| KL3 | 3, 7 | 0-10 V | Use control input/current sensor value input 0-10 VDC, impedance 100 k Ω only as alternative to 4-20 mA input, SELV |
| KL3 | 4 | +10 V | Voltage output 10 VDC ($\pm 3\%$), max. 10 mA, power supply for external devices (e.g. potentiometer), SELV |
| KL3 | 5 | +20 V | Voltage output 20 VDC (+25%/-10%), max. 50 mA, power supply for external devices (e.g. sensors), SELV |
| KL3 | 6 | 4-20 mA | Use control input/current sensor value input 4-20 mA, impedance 100 Ω only as alternative to 0-10 V input, SELV |
| KL3 | 9, 11 | RSB | RS485 interface for ebmBus, RSB, SELV |
| KL3 | 10, 12 | RSA | RS485 interface for ebmBus, RSA, SELV |



Curves: Air performance 50 Hz

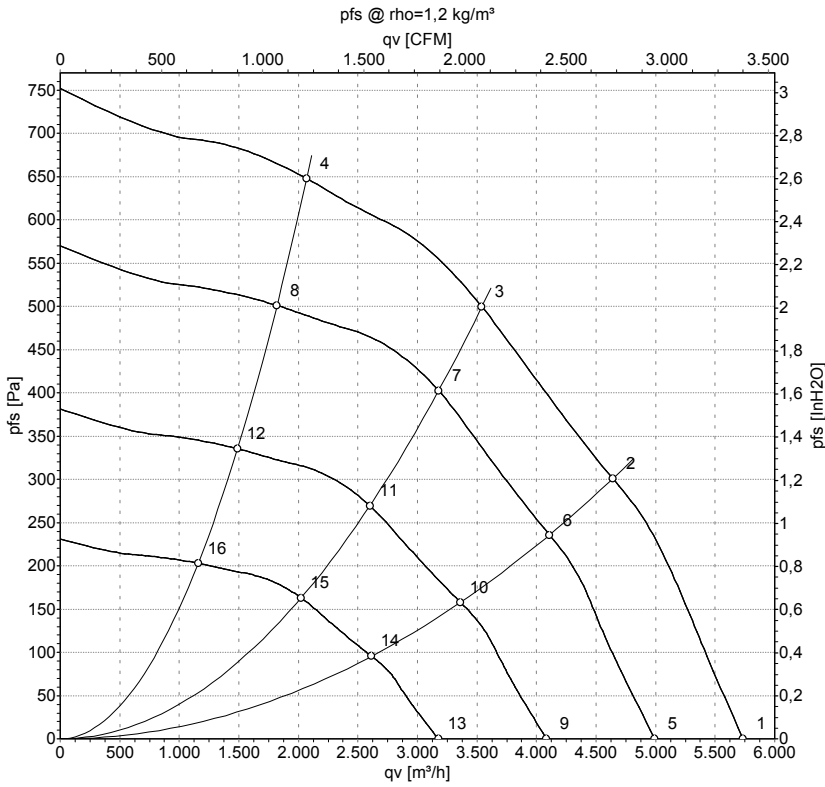

Measurement: LU-107848-1

Air performance measured according to ISO 5801 installation category A. For detailed information on the measurement setup, contact ebm-papst. Intake sound level: Sound power level according to ISO 13347 / sound pressure level measured at 1 m distance from fan axis. The values given are valid under the specified measuring conditions and may vary due to conditions of installation. For deviations from the standard configuration, the parameters have to be checked on the installed unit.

Measured values

| | U | f | n | P _{ed} | I | LpA _{in} | LwA _{in} | LwA _{out} | q _v | P _{fs} | q _v | P _{fs} |
|----|-----|----|-------------------|-----------------|------|-------------------|-------------------|--------------------|-------------------|-----------------|----------------|--------------------|
| | V | Hz | min ⁻¹ | W | A | dB(A) | dB(A) | dB(A) | m ³ /h | Pa | cfm | inH ₂ O |
| 1 | 200 | 50 | 1880 | 749 | 2.33 | 76 | 82 | 88 | 5735 | 0 | 3375 | 0.00 |
| 2 | 200 | 50 | 1880 | 855 | 2.68 | 73 | 80 | 85 | 4640 | 300 | 2730 | 1.20 |
| 3 | 200 | 50 | 1880 | 1000 | 2.90 | 70 | 77 | 82 | 3540 | 500 | 2085 | 2.01 |
| 4 | 200 | 50 | 1880 | 847 | 2.68 | 74 | 81 | 86 | 2070 | 650 | 1220 | 2.61 |
| 5 | 200 | 50 | 1650 | 493 | 1.54 | 72 | 79 | 84 | 4990 | 0 | 2940 | 0.00 |
| 6 | 200 | 50 | 1650 | 593 | 1.86 | 70 | 76 | 82 | 4110 | 236 | 2420 | 0.95 |
| 7 | 200 | 50 | 1650 | 665 | 2.09 | 68 | 74 | 80 | 3180 | 406 | 1870 | 1.63 |
| 8 | 200 | 50 | 1650 | 576 | 1.83 | 71 | 78 | 82 | 1820 | 502 | 1070 | 2.02 |
| 9 | 200 | 50 | 1350 | 270 | 0.84 | 67 | 74 | 79 | 4085 | 0 | 2405 | 0.00 |
| 10 | 200 | 50 | 1350 | 325 | 1.02 | 65 | 71 | 77 | 3360 | 158 | 1980 | 0.63 |
| 11 | 200 | 50 | 1350 | 364 | 1.14 | 63 | 69 | 75 | 2600 | 272 | 1530 | 1.09 |
| 12 | 200 | 50 | 1350 | 316 | 1.00 | 66 | 73 | 77 | 1490 | 336 | 875 | 1.35 |
| 13 | 200 | 50 | 1050 | 127 | 0.40 | 61 | 67 | 73 | 3175 | 0 | 1870 | 0.00 |
| 14 | 200 | 50 | 1050 | 153 | 0.48 | 58 | 65 | 71 | 2615 | 95 | 1540 | 0.38 |
| 15 | 200 | 50 | 1050 | 171 | 0.54 | 56 | 63 | 68 | 2020 | 164 | 1190 | 0.66 |
| 16 | 200 | 50 | 1050 | 149 | 0.47 | 59 | 66 | 71 | 1160 | 203 | 680 | 0.81 |

U = Power supply · f = Frequency · n = Speed (rpm) · P_{ed} = Power consumption · I = Current draw · LpA_{in} = Sound pressure level intake side · LwA_{in} = Sound power level intake side
 LwA_{out} = Sound power level outlet side · q_v = Air flow · P_{fs} = Pressure increase

