

R3G400-AK53-07 ebmpapst Datasheet

sales@fansco.com

www.fansco.com

Limited partnership · Headquarters Muldingen

Amtsgericht (court of registration) Stuttgart · HRA 590344

General partner Elektrobau Muldingen GmbH · Headquarters Muldingen

Amtsgericht (court of registration) Stuttgart · HRB 590142



## Nominal data

Type	R3G400-AK53-07	
Motor	M3G112-EA	
Phase		3~
Nominal voltage	VAC	400
Nominal voltage range	VAC	380 .. 480
Frequency	Hz	50/60
Method of obtaining data		ml
Speed	min <sup>-1</sup>	1880
Power consumption	W	1000
Current draw	A	1.6
Min. ambient temperature	°C	-25
Max. ambient temperature	°C	60

ml = Max. load · me = Max. efficiency · fa = Free air · cs = Customer specification · ce = Customer equipment  
Subject to change

## Data according to ErP Directive

		Actual	Req. 2015			
01 Overall efficiency $\eta_{es}$	%	58.7	51.5	09 Power consumption $P_{ed}$	kW	0.99
02 Measurement category		A		09 Air flow $q_v$	m <sup>3</sup> /h	3505
03 Efficiency category		Static		09 Pressure increase $p_{fs}$	Pa	554
04 Efficiency grade N		69.2	62	10 Speed n	min <sup>-1</sup>	1895
05 Variable speed drive		Yes		11 Specific ratio <sup>*</sup>		1.01

Data obtained at optimum efficiency level.

The ErP data is determined using a motor-impeller combination in a standardized measurement setup.

<sup>\*</sup> Specific ratio =  $1 + p_{fs} / 100\,000\text{ Pa}$

LU-107842



## Technical description

Weight	8.9 kg
Fan size	400 mm
Rotor surface	Painted black
Electronics housing material	Die-cast aluminum
Impeller material	Sheet aluminum
Number of blades	6
Direction of rotation	Clockwise, viewed toward rotor
Degree of protection	IP54
Insulation class	"B"
Moisture (F) / Environmental (H) protection class	F4-1
Max. permitted ambient temp. for motor (transport/storage)	+ 80 °C
Min. permitted ambient temp. for motor (transport/storage)	- 40 °C
Installation position	Any
Condensation drainage holes	On rotor and stator sides
Mode	S1
Motor bearing	Ball bearing
Technical features	<ul style="list-style-type: none"> <li>- Output 10 VDC, max. 10 mA</li> <li>- Output 20 VDC, max. 50 mA</li> <li>- Output for slave 0-10 V</li> <li>- Input for sensor 0-10 V or 4-20 mA</li> <li>- Alarm relay</li> <li>- Integrated PID controller</li> <li>- Motor current limitation</li> <li>- PFC, passive</li> <li>- RS-485 ebmBUS</li> <li>- Soft start</li> <li>- Control input 0-10 VDC / PWM</li> <li>- Control interface with SELV potential safely disconnected from the mains</li> <li>- Thermal overload protection for electronics/motor</li> <li>- Line undervoltage / phase failure detection</li> </ul>
EMC immunity to interference	According to EN 61000-6-2 (industrial environment)
EMC circuit feedback	According to EN 61000-3-2/3
EMC interference emission	According to EN 61000-6-3 (household environment)
Touch current according to IEC 60990 (measuring circuit Fig. 4, TN system)	<= 3.5 mA
Electrical hookup	Via terminal box
Motor protection	Thermal overload protector (TOP) internally connected
Protection class	I (with customer connection of protective earth)
Conformity with standards	EN 61800-5-1; CE
Approval	UL 1004-7 + 60730; VDE

Product drawing

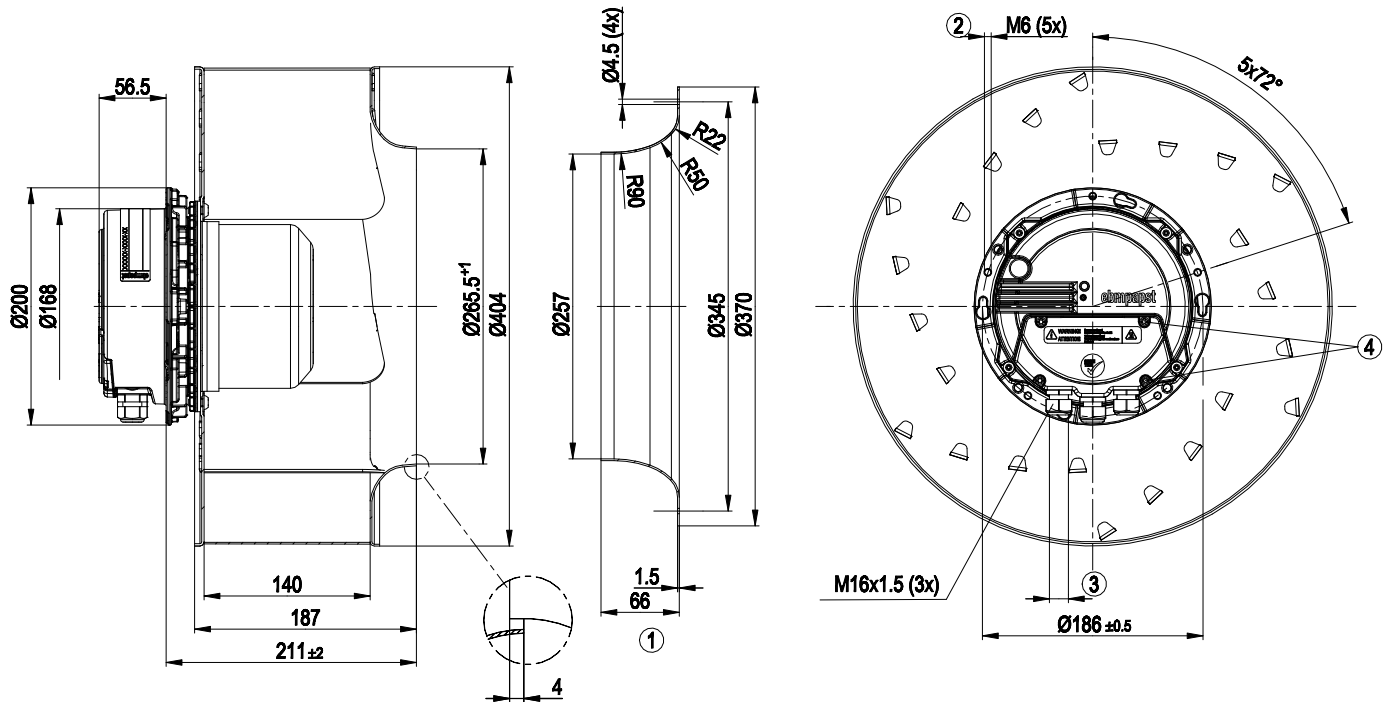

1	Accessory part: inlet ring 54476-2-4013 not included in scope of delivery
2	Max. clearance for screw 16 mm
3	Cable diameter min. 4 mm; max. 10 mm; tightening torque $2.5 \pm 0.4$ Nm
4	Tightening torque $3.5 \pm 0.5$ Nm

## Connection diagram

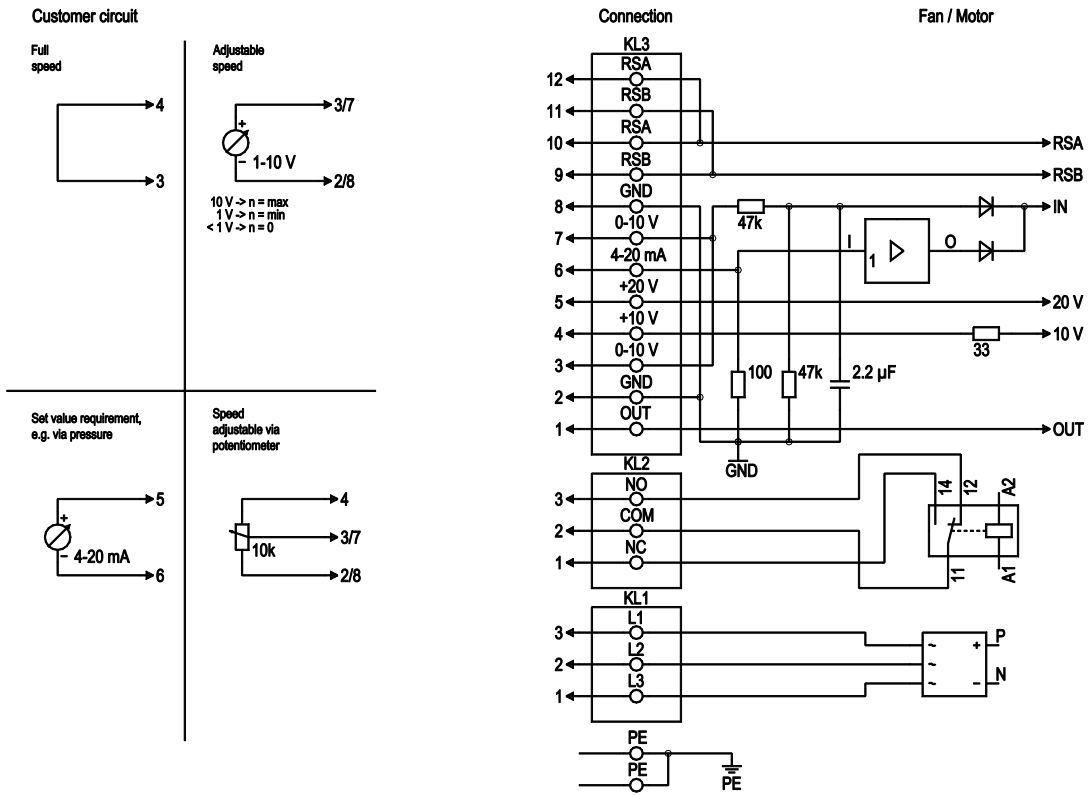

No.	Conn.	Designation	Function/assignment
PE		PE	Protective earth terminal
KL1	1, 2, 3	L1, L2, L3	Power supply, voltage range (see nameplate), 50/60 Hz
KL2	1	NC	Floating status contact, break for failure
KL2	2	COM	floating status contact, changeover contact, common connection (2 A, max. 250 VAC, min. 10 mA, AC1)
KL2	3	NO	Floating status contact, make for failure
KL3	1	OUT	Analog output, 0-10 VDC, max. 3 mA, SELV, output of current motor modulation level: 1 V corresponds to 10% modulation level. 10 V corresponds to 100% modulation level.
KL3	2, 8	GND	Reference ground for control interface, SELV
KL3	3, 7	0-10 V	Use control / current sensor value input 0-10 VDC, impedance 100 kΩ only as alternative to 4-20 mA input, SELV
KL3	4	+10 V	Voltage output 10 VDC (±3%), max. 10 mA, power supply for external devices (e.g. potentiometer), SELV
KL3	5	+20 V	Voltage output 20 VDC (+25%/-10%), max. 50 mA, power supply for external devices (e.g. sensors), SELV
KL3	6	4-20 mA	Use control / current sensor value input 4-20 mA, impedance 100 Ω only as alternative to 0-10 V input, SELV
KL3	9, 11	RSB	RS485 interface for MODBUS, RSB
KL3	10, 12	RSA	RS485 interface for MODBUS, RSA

## Curves: Air performance 50 Hz

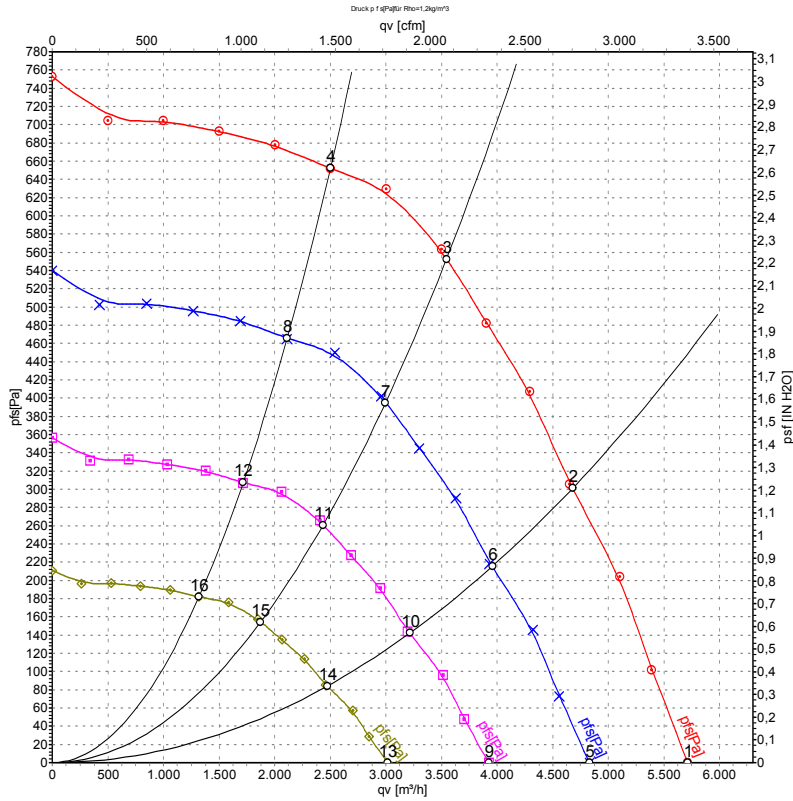

Measurement: LU-107842-1

Air performance measured according to ISO 5801 installation category A. For detailed information on the measurement setup, contact ebmpapst. Intake sound level: Sound power level according to ISO 13347 / sound pressure level measured at 1 m distance from fan axis. The values given are valid under the specified measuring conditions and may vary due to conditions of installation. For deviations from the standard configuration, the parameters have to be checked on the installed unit.

## Measured values

	U	f	n	P <sub>ed</sub>	I	LpA <sub>in</sub>	LwA <sub>in</sub>	LwA <sub>out</sub>	qv	P <sub>fs</sub>
	V	Hz	min <sup>-1</sup>	W	A	dB(A)	dB(A)	dB(A)	m <sup>3</sup> /h	Pa
1	400	50	1880	762	1.27	76	82	88	5715	0
2	400	50	1880	871	1.43	73	80	86	4680	300
3	400	50	1880	1000	1.60	71	78	83	3545	550
4	400	50	1880	896	1.46	73	80	85	2500	650
5	400	50	1600	460	0.77	72	79	84	4830	0
6	400	50	1600	527	0.86	69	76	82	3960	214
7	400	50	1600	602	0.94	67	74	80	2995	396
8	400	50	1600	540	0.88	70	77	81	2115	465
9	400	50	1300	247	0.41	68	74	80	3925	0
10	400	50	1300	283	0.46	65	72	78	3215	141
11	400	50	1300	323	0.51	63	69	75	2435	262
12	400	50	1300	290	0.47	65	72	77	1715	307
13	400	50	1000	112	0.19	62	68	74	3020	0
14	400	50	1000	129	0.21	59	66	72	2475	84
15	400	50	1000	147	0.23	57	64	69	1875	155
16	400	50	1000	132	0.21	59	66	71	1320	182

U = Power supply · f = Frequency · n = Speed · P<sub>ed</sub> = Power consumption · I = Current draw · LpA<sub>in</sub> = Sound pressure level intake side · LwA<sub>in</sub> = Sound power level intake side  
 LwA<sub>out</sub> = Sound power level outlet side · qv = Air flow · P<sub>fs</sub> = Pressure increase

