

R3G400-AK53-01 ebmpapst Datasheet

sales@fansco.com

www.fansco.com

Limited partnership · Headquarters Muldingen
County court Stuttgart · HRA 590344

General partner Elektrobau Muldingen GmbH · Headquarters Muldingen
County court Stuttgart · HRB 590142



Nominal data

Type	R3G400-AK53-01	
Motor	M3G112-EA	
Phase		3~
Nominal voltage	VAC	400
Nominal voltage range	VAC	380 .. 480
Frequency	Hz	50/60
Type of data definition		ml
Speed	min ⁻¹	1880
Power input	W	1000
Current draw	A	1.6
Min. ambient temperature	°C	-25
Max. ambient temperature	°C	60

ml = max. load · me = max. efficiency · fa = running at free air · cs = customer specs · cu = customer unit
Subject to alterations

Data according to ErP directive

		Actual	Request 2013	Request 2015
Installation category	A			
Efficiency category	Static			
Variable speed drive	Yes			
Specific ratio*	1.01			
Overall efficiency η_{es}		58.6	47.4	51.4
Efficiency grade N		69.2	58	62
Power input P_{ed}	kW	0.98		
Air flow q_v	m ³ /h	3505		
Pressure increase p_{fs}	Pa	546		
Speed n	min ⁻¹	1895		

Data established at point of optimum efficiency

* Specific ratio = $1 + p_{fs} / 100\,000\text{ Pa}$



Technical features

Mass	8.5 kg
Size	400 mm
Surface of rotor	Coated in black
Material of electronics housing	Die-cast aluminium
Material of impeller	Aluminium sheet
Number of blades	6
Direction of rotation	Clockwise, seen on rotor
Type of protection	IP 54
Insulation class	"B"
Humidity class	F4-1
Max. permissible ambient motor temp. (transp./ storage)	+ 80 °C
Min. permissible ambient motor temp. (transp./storage)	- 40 °C
Mounting position	Shaft horizontal or rotor on bottom; rotor on top on request
Operation mode	S1
Motor bearing	Ball bearing
Technical features	<ul style="list-style-type: none"> - Output 10 VDC, max. 10 mA - Output 20 VDC, max. 50 mA - Output for slave 0-10 V - Input for sensor 0-10 V or 4-20 mA - Alarm relay - Integrated PID controller - Motor current limit - PFC, passive - RS485 ebmBUS - Soft start - Control input 0-10 VDC / PWM - Control interface with SELV potential safely disconnected from the mains - Over-temperature protected electronics / motor - Line undervoltage / phase failure detection
EMC interference immunity	Acc. to EN 61000-6-2 (industrial environment)
EMC harmonics	Acc. to EN 61000-3-2/3
EMC interference emission	Acc. to EN 61000-6-3 (household environment)
Touch current acc. IEC 60990 (measuring network Fig. 4, TN system)	<= 3.5 mA
Electrical leads	Via terminal box
Motor protection	Thermal overload protector (TOP) wired internally
Protection class	I (if protective earth is connected by customer)

EC centrifugal fan

backward curved, single inlet

Product drawing

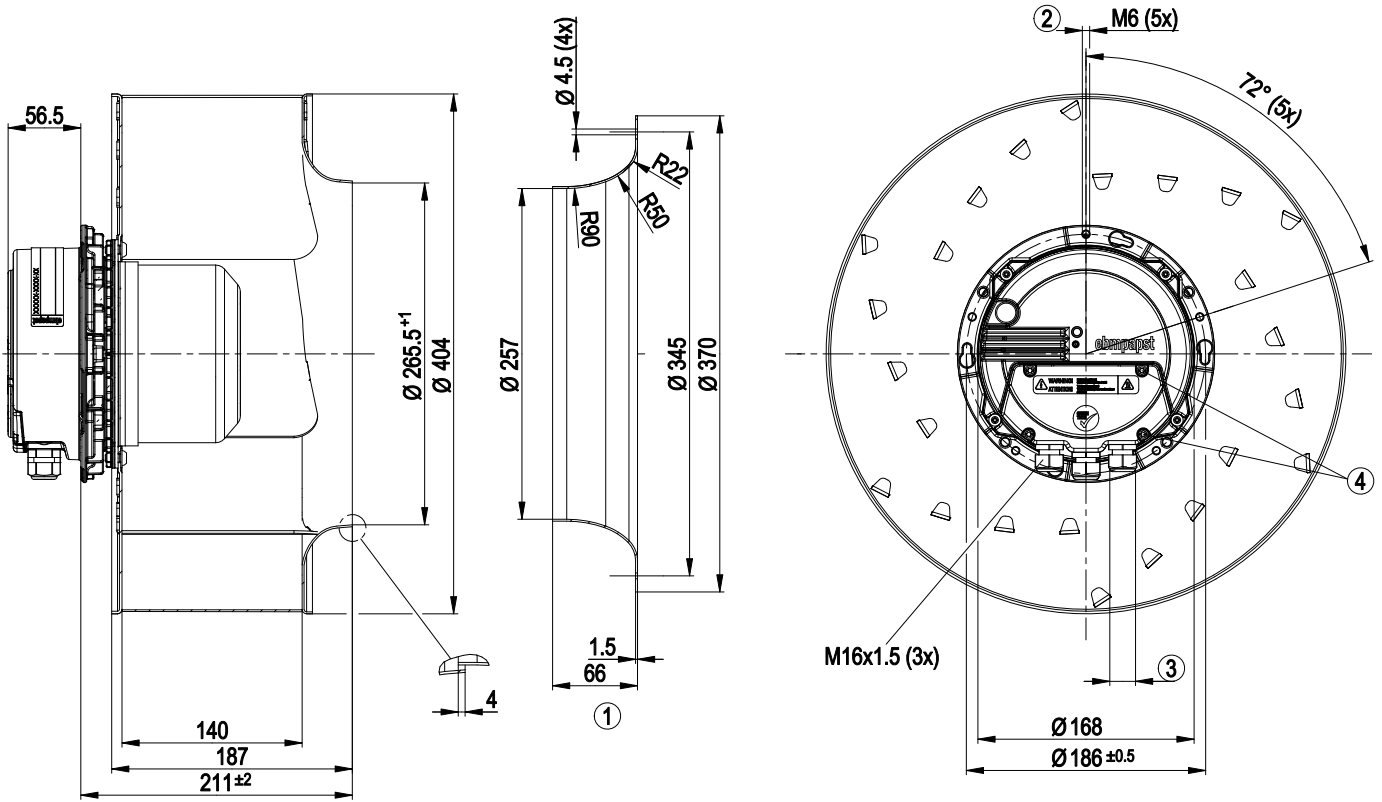

1	Accessory part: Inlet nozzle 54476-2-4013, not included in the standard scope of delivery
2	Depth of screw max. 16 mm
3	Cable diameter: min. 4 mm; max. 10 mm; tightening torque: 2.5±0.4 Nm
4	Tightening torque 3.5±0.5 Nm



Connection screen

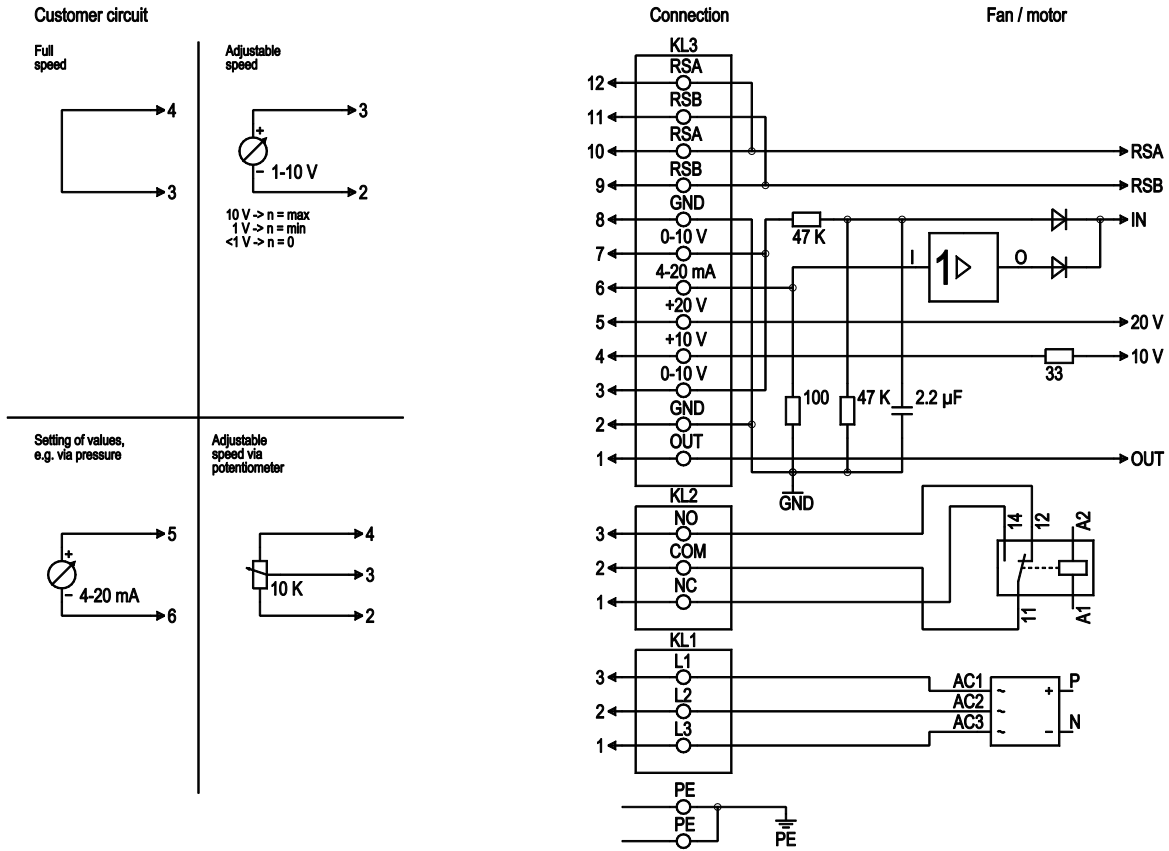

No.	Pin	Signal	Function / assignment
PE		PE	Protective earth connection
KL1	1, 2, 3	L1, L2, L3	Supply voltage, 50/60 Hz
KL2	1	NC	Floating status message contact, normally closed connection
KL2	2	COM	Floating status message contact, changeover contact, common connection (2 A, max. 250 VAC, min. 10 mA, AC1)
KL2	3	NO	Floating status message contact, normally open connection
KL3	1	OUT	Analog output, 0-10 VDC, max. 3 mA, SELV, output of the current level control coefficient: 1 V equates to 10% level control coefficient. 10 V equate to 100% level control coefficient.
KL3	2, 8	GND	Reference mass for control interface, SELV
KL3	3, 7	0-10 V	Use control / actual value input 0-10 VDC, impedance 100 kΩ only as alternative to 4-20 mA input, SELV
KL3	4	+10 V	Voltage output 10 VDC (+/-3%), max. 10 mA, supply voltage for external devices (e.g. potentiometers), SELV
KL3	5	+20 V	Voltage output 20 VDC (+25%/-10%), max. 50 mA, supply voltage for external devices (e.g. sensors), SELV
KL3	6	4-20 mA	Use control / actual value input 4-20 mA, impedance 100 Ω, only as alternative to 0-10 V input, SELV
KL3	9, 11	RSB	RS485 interface for ebmBus, RSB, SELV
KL3	10, 12	RSA	RS485 interface for ebmBus, RSA, SELV

Charts: Air flow 50 Hz

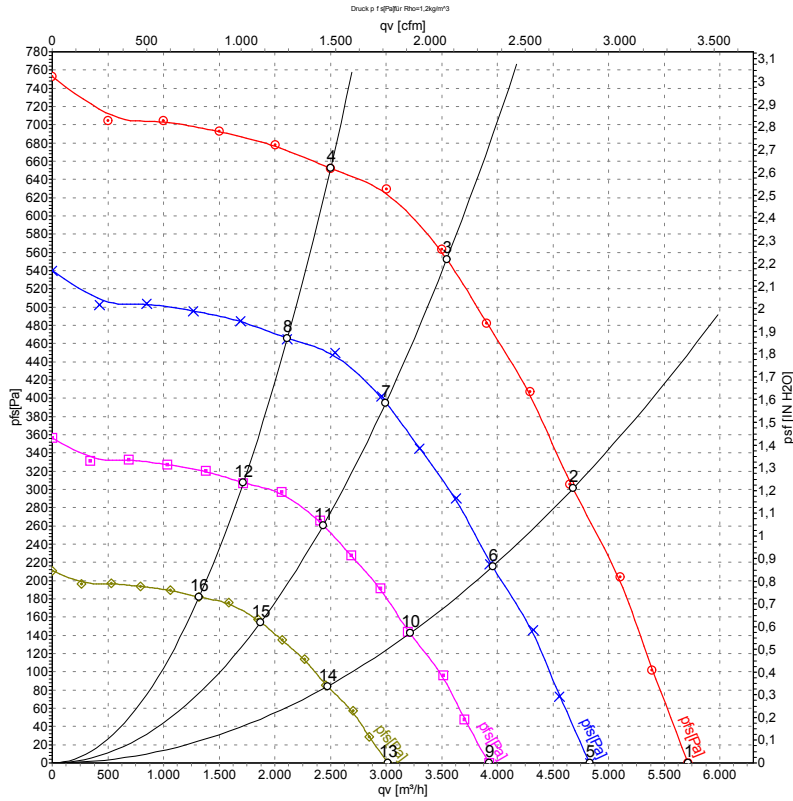

Measurement: LU-107842

Air performance measured as per ISO 5801 Installation category A. For detailed information on the measuring set-up, please contact ebmpapst. Suction-side noise levels: LwA measured as per ISO 13347 / LpA measured with 1m distance to fan axis. The values given are valid under the measuring conditions mentioned above and may vary according to the actual installation situation. With any deviation from the standard set-up, the specific values have to be checked and reviewed with the unit installed.

Measured values

	U	f	n	P _{ed}	I	LpA _{in}	LwA _{in}	LwA _{out}	qv	p _{fs}
	V	Hz	min ⁻¹	W	A	dB(A)	dB(A)	dB(A)	m ³ /h	Pa
1	400	50	1880	762	1.27	76	82	88	5715	0
2	400	50	1880	871	1.43	73	80	86	4680	300
3	400	50	1880	1000	1.60	71	78	83	3545	550
4	400	50	1880	896	1.46	73	80	85	2500	650
5	400	50	1600	460	0.77	72	79	84	4830	0
6	400	50	1600	527	0.86	69	76	82	3960	214
7	400	50	1600	602	0.94	67	74	80	2995	396
8	400	50	1600	540	0.88	70	77	81	2115	465
9	400	50	1300	247	0.41	68	74	80	3925	0
10	400	50	1300	283	0.46	65	72	78	3215	141
11	400	50	1300	323	0.51	63	69	75	2435	262
12	400	50	1300	290	0.47	65	72	77	1715	307
13	400	50	1000	112	0.19	62	68	74	3020	0
14	400	50	1000	129	0.21	59	66	72	2475	84
15	400	50	1000	147	0.23	57	64	69	1875	155
16	400	50	1000	132	0.21	59	66	71	1320	182

U = Supply voltage · f = Frequency · n = Speed · P_{ed} = Power input · I = Current draw · LpA_{in} = Sound pressure level inlet side · LwA_{in} = Sound power level inlet side · LwA_{out} = Sound power level outlet side
 qv = Air flow · p_{fs} = Pressure increase

