

EC centrifugal fan

backward-curved, single-intake

for rail applications

R3G400-AD15-13 ebmpapst Datasheet

sales@fansco.com

www.fansco.com

Limited partnership · Headquarters Muldingen

Amtsgericht (court of registration) Stuttgart · HRA 590344

General partner Elektrobau Muldingen GmbH · Headquarters Muldingen

Amtsgericht (court of registration) Stuttgart · HRB 590142

Nominal data

Type	R3G400-AD15-13	
Motor	M3G084-FA	
Nominal voltage	VDC	110
Nominal voltage range	VDC	77 .. 115
Method of obtaining data		fa
Speed (rpm)	min ⁻¹	1670
Power consumption	W	450
Current draw	A	4.1
Min. ambient temperature	°C	-25
Max. ambient temperature	°C	40

ml = Max. load · me = Max. efficiency · fa = Free air · cs = Customer specification · ce = Customer equipment
Subject to change



EC centrifugal fan

backward-curved, single-intake
for rail applications

Technical description

Weight	5.4 kg
Fan size	400 mm
Rotor surface	Painted black
Impeller material	Sheet aluminum
Number of blades	6
Direction of rotation	Clockwise, viewed toward rotor
Degree of protection	IP22
Insulation class	"B"
Moisture (F) / Environmental (H) protection class	F4-1
Max. permitted ambient temp. for motor (transport/storage)	+80 °C
Min. permitted ambient temp. for motor (transport/storage)	-40 °C
Installation position	Shaft horizontal or rotor on bottom; rotor on top on request
Condensation drainage holes	On rotor side
Mode	S1
Motor bearing	Ball bearing
Motor protection	PTC thermistor
With cable	Lateral
Protection class	I (with customer connection of protective earth)



EC centrifugal fan

backward-curved, single-intake
for rail applications

Product drawing

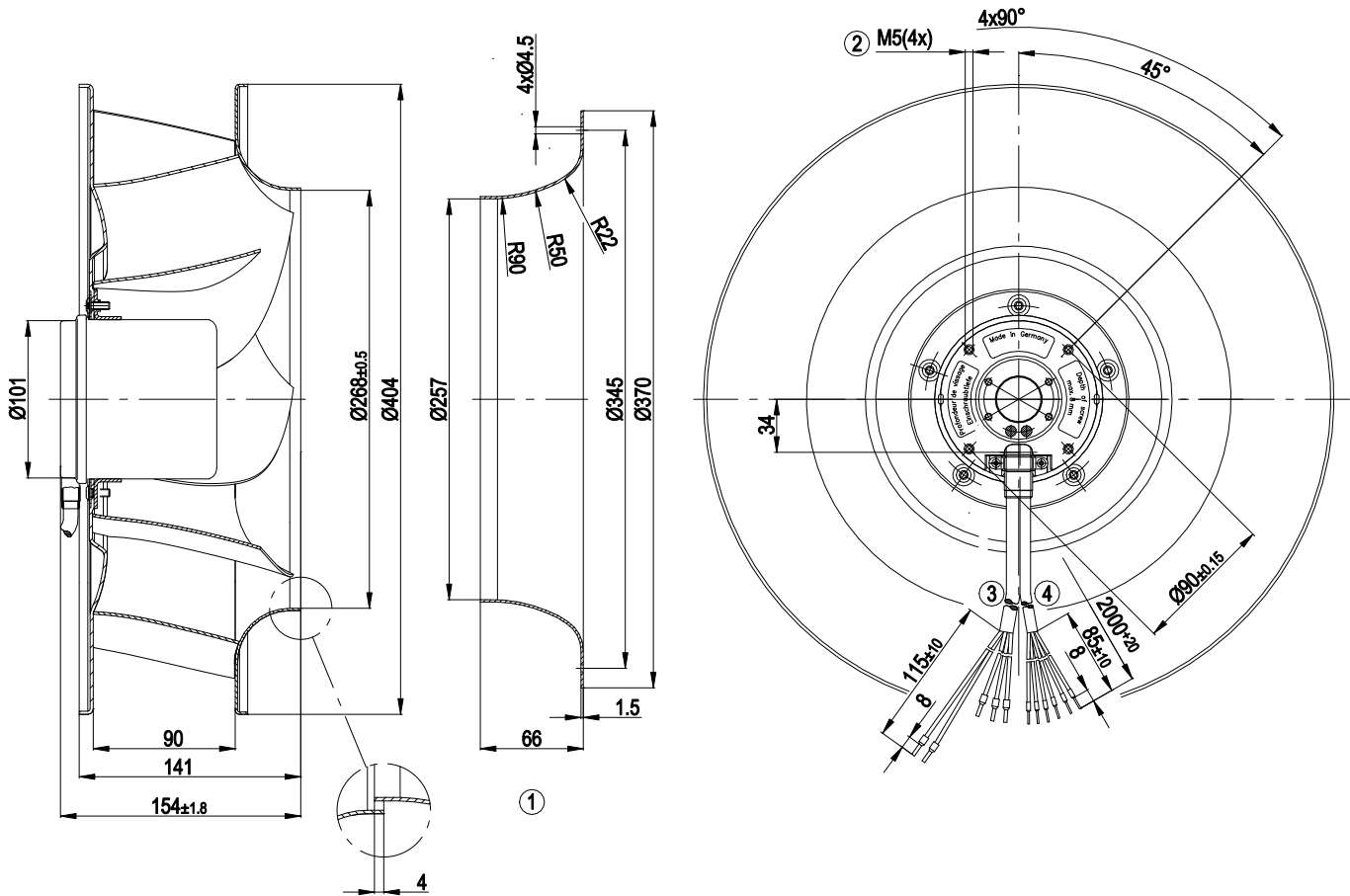

1	Accessory part: Inlet ring 54476-2-4013 not included in scope of delivery, other inlet rings on request
2	Max. clearance for screw 8 mm
3	Cable silicone 5x1.0 mm ² ; 5x crimped ferrules
4	Cable silicone 6x0.5 mm ² ; 6x crimped ferrules
5	Accessory part: external electronics CEG485-HB50-01 not included in scope of delivery



EC centrifugal fan

backward-curved, single-intake
for rail applications

Connection diagram

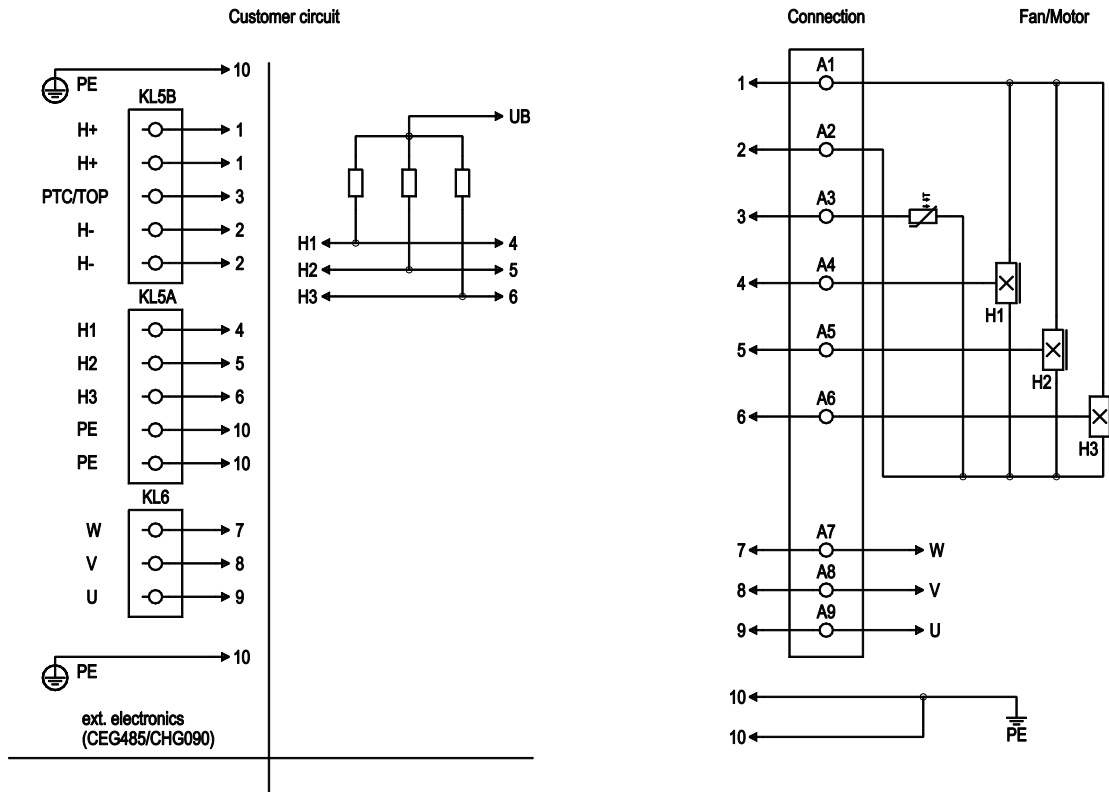

No.	Conn.	Designation	Function/assignment
KL5A	4	A4	Hall 1 (orange) collector open, R to UB 4.5-24 V
KL5A	5	A5	Hall 2 (brown) collector open, R to UB 4.5-24 V
KL5A	6	A6	Hall 3 (yellow) collector open, R to UB 4.5-24 V
KL5B	1	A1	+ (red)
KL5B	2	A2	- (blue)
KL5B	3	A3	PTC (black)
KL6	7	A7	W (brown)
KL6	8	A8	V (blue)
KL6	9	A9	U (black)
-	10	-	PE (green/yellow) - 2x



Curves: Air performance

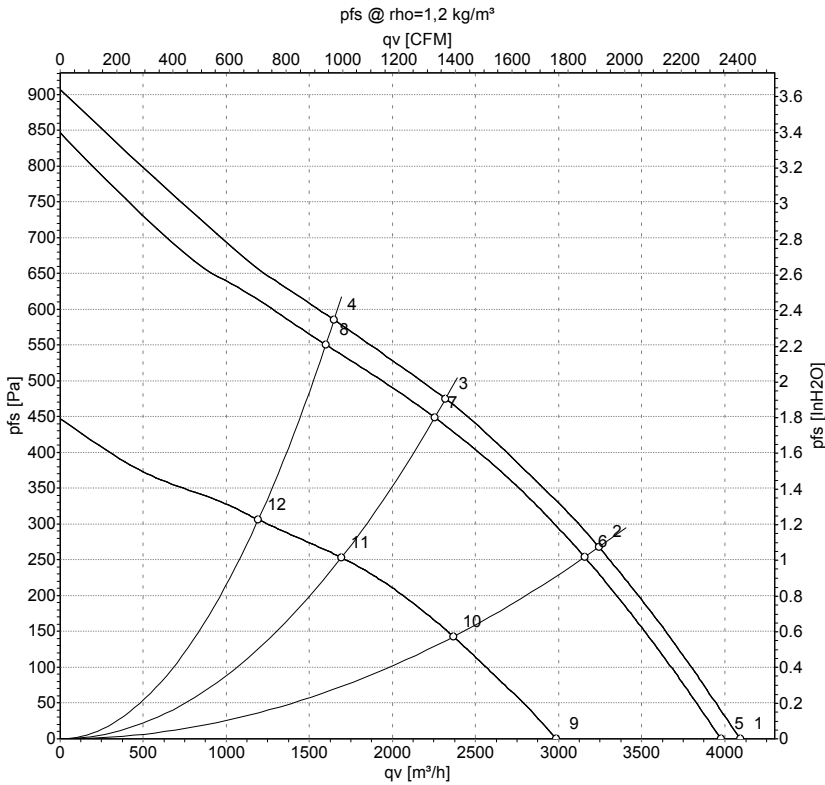

Measurement: LU-51929-1
 Measurement: LU-51928-1
 Measurement: LU-51927-1

Air performance measured according to ISO 5801 installation category A. For detailed information on the measurement setup, contact ebmpapst. Intake sound level: Sound power level according to ISO 13347 / sound pressure level measured at 1 m distance from fan axis. The values given are valid under the specified measuring conditions and may vary due to conditions of installation. For deviations from the standard configuration, the parameters have to be checked on the installed unit.

Measured values

	Wired	U	n	P _{ed}	I	q _v	p _{fs}	q _v	p _{fs}
		V	min ⁻¹	W	A	m ³ /h	Pa	cfm	inH ₂ O
1	Δ	115	1715	502	4.39	4095	0	2410	0.00
2	Δ	115	1655	569	4.98	3240	268	1910	1.08
3	Δ	115	1650	572	5.01	2320	476	1365	1.91
4	Δ	115	1680	538	4.70	1650	585	970	2.35
5	Δ	110	1670	450	4.10	3975	0	2340	0.00
6	Δ	110	1610	517	4.72	3155	250	1860	1.00
7	Δ	110	1605	520	4.74	2255	450	1325	1.81
8	Δ	110	1630	488	4.44	1600	550	940	2.21
9	Δ	77	1240	185	2.42	2985	0	1755	0.00
10	Δ	77	1210	214	2.79	2365	143	1395	0.57
11	Δ	77	1205	217	2.84	1695	253	995	1.02
12	Δ	77	1220	204	2.67	1190	306	700	1.23

Wired = Wiring · U = Power supply · n = Speed (rpm) · P_{ed} = Power consumption · I = Current draw · q_v = Air flow · p_{fs} = Pressure increase

