

R3G400-AC13-30

EC centrifugal fan

backward-curved, single-intake



R3G400-AC13-30 ebmpapst Datasheet FansCo

sales@fansco.com

www.fansco.com

Nominal data

Type	R3G400-AC13-30	
Motor	M3G084-FA	
Nominal voltage	VDC	48
Nominal voltage range	VDC	36 .. 57
Method of obtaining data		fa
Speed (rpm)	min ⁻¹	1160
Power consumption	W	192
Current draw	A	3.9
Min. ambient temperature	°C	-25
Max. ambient temperature	°C	60

ml = Max. load · me = Max. efficiency · fa = Free air · cs = Customer specification · ce = Customer equipment
Subject to change

Data according to Commission Regulation (EU) 327/2011

		Actual	Req. 2015
01 Overall efficiency η_{es}	%	61.7	44.2
02 Measurement category		A	
03 Efficiency category		Static	
04 Efficiency grade N		79.5	62
05 Variable speed drive		Yes	

Data obtained at optimum efficiency level.
The ErP data is determined using a motor-impeller combination in a standardized measurement setup.

09 Power consumption P_e	kW	0.2
09 Air flow q_v	m ³ /h	1565
09 Pressure increase p_{fs}	Pa	250
10 Speed (rpm) n	min ⁻¹	1135
11 Specific ratio*		1.00

* Specific ratio = $1 + p_{fs} / 100\,000\text{ Pa}$

LU-57658



Technical description

Weight	5 kg
Fan size	400 mm
Electronics housing material	Die-cast aluminum
Impeller material	Sheet aluminum
Number of blades	6
Direction of rotation	Clockwise, viewed toward rotor
Degree of protection	IP42
Insulation class	"B"
Moisture (F) / Environmental (H) protection class	H1
Max. permitted ambient temp. for motor (transport/storage)	+80 °C
Min. permitted ambient temp. for motor (transport/storage)	-40 °C
Installation position	Any
Condensation drainage holes	None
Mode	S1
Motor bearing	Ball bearing
Technical features	<ul style="list-style-type: none"> - Tach output - Power limiter - Motor current limitation - Soft start - Control input 0-10 VDC / PWM - Thermal overload protection for motor
Motor protection	Thermal overload protector (TOP) internally connected
With cable	Variable
Protection class	I (with customer connection of protective earth)
Conformity with standards	EN 60950-1; CE
Approval	CSA C22.2 No. 100; UL 1004-1; CCC; EAC

Product drawing

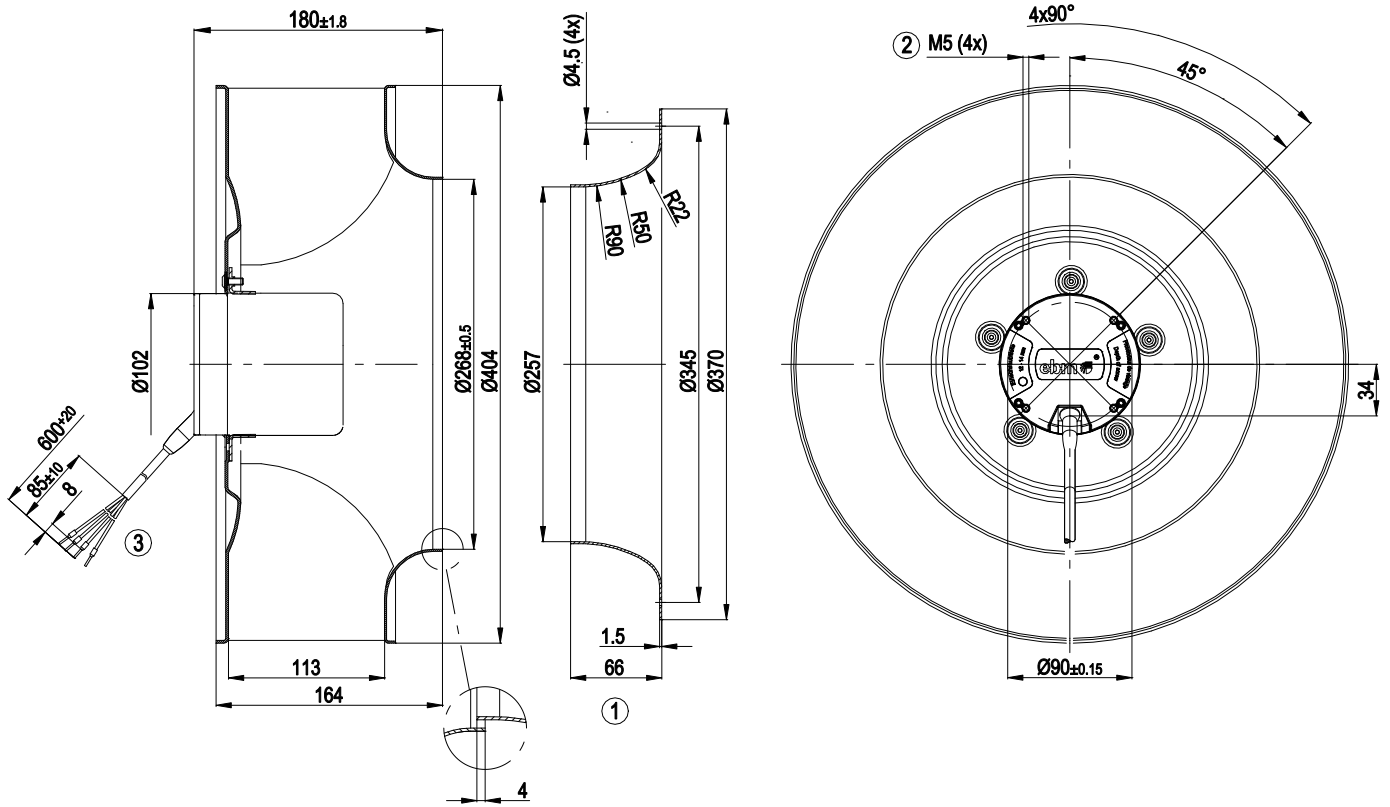

1	Accessory part: inlet ring 54476-2-4013 not included in scope of delivery
2	Max. clearance for screw 14 mm
3	Cable PVC AWG16, 4x crimped ferrules



Connection diagram

Customer circuit

Application notes for various control options

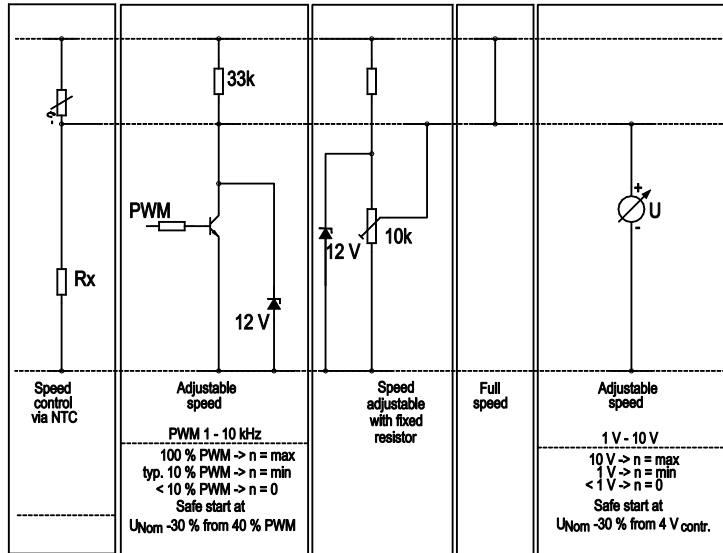

Connection
Supply voltage ripple ±3.5%

Fan / Motor

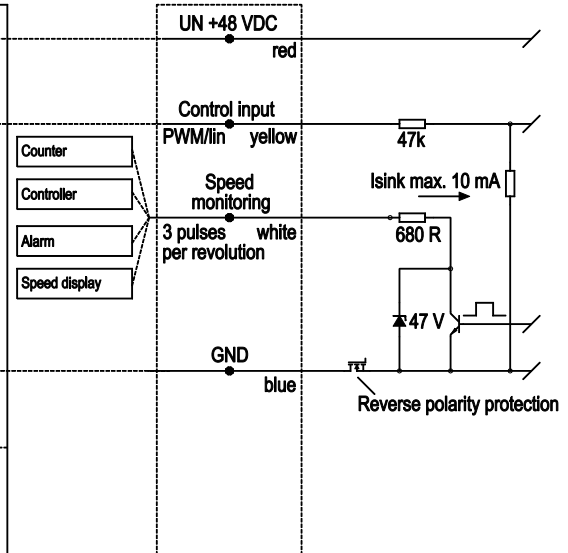

Curves: Air performance

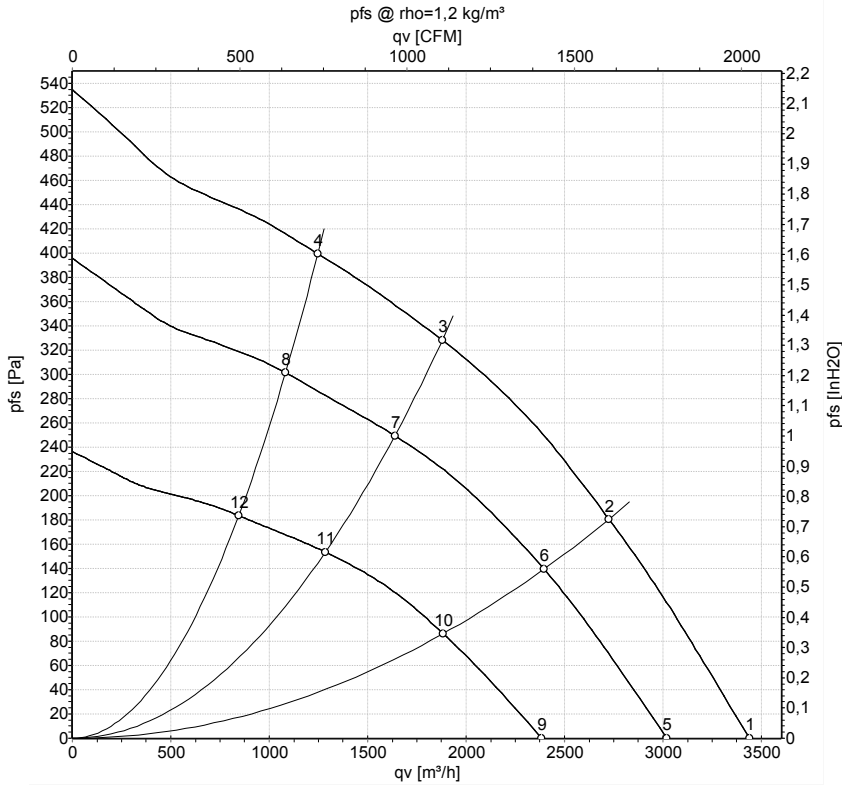

Measurement: LU-57659-1
 Measurement: LU-57658-1
 Measurement: LU-57660-1

Air performance measured according to ISO 5801 installation category A. For detailed information on the measurement setup, contact ebmpapst. Intake sound level: Sound power level according to ISO 13347 / sound pressure level measured at 1 m distance from fan axis. The values given are valid under the specified measuring conditions and may vary due to conditions of installation. For deviations from the standard configuration, the parameters have to be checked on the installed unit.

Measured values

	U	n	P _{ed}	I	q _v	p _{fs}	q _v	p _{fs}
	V	min ⁻¹	W	A	m ³ /h	Pa	cfm	inH2O
1	57	1320	284	5.04	3435	0	2025	0.00
2	57	1290	321	5.71	2725	181	1605	0.73
3	57	1300	309	5.49	1880	328	1105	1.32
4	57	1330	275	4.87	1245	399	735	1.60
5	48	1160	192	3.90	3020	0	1775	0.00
6	48	1125	211	4.43	2395	140	1410	0.56
7	48	1135	203	4.27	1640	250	965	1.00
8	48	1155	180	3.78	1085	300	635	1.20
9	36	900	91	2.53	2385	0	1405	0.00
10	36	890	102	2.85	1885	86	1110	0.35
11	36	895	99	2.76	1285	154	755	0.62
12	36	905	88	2.46	845	184	495	0.74

U = Power supply · n = Speed (rpm) · P_{ed} = Power consumption · I = Current draw · q_v = Air flow · p_{fs} = Pressure increase

