

R3G355-RT01-M4

Stulz GmbH

EC centrifugal fan - RadiCal

backward-curved, single-intake

with guard grille

R3G355-RT01-M4 ebmpapst Datasheet

sales@fansco.com

www.fansco.com

Limited partnership · Headquarters Muldingen

Amtsgericht (court of registration) Stuttgart · HRA 590344

General partner Elektrobau Muldingen GmbH · Headquarters Muldingen

Amtsgericht (court of registration) Stuttgart · HRB 590142

Nominal data

Type	R3G355-RT01-M4	
Motor	M3G084-GF	
Phase		3~
Nominal voltage	VAC	400
Nominal voltage range	VAC	380 .. 480
Frequency	Hz	50/60
Method of obtaining data		ml
Speed (rpm)	min ⁻¹	2100
Power consumption	W	700
Current draw	A	1.1
Min. ambient temperature	°C	-25
Max. ambient temperature	°C	55

ml = Max. load · me = Max. efficiency · fa = Free air · cs = Customer specification · ce = Customer equipment
Subject to change

Data according to Commission Regulation (EU) 327/2011 (EN 17166)

		Actual	Req. 2015			
01 Overall efficiency η_{es}	%	65.2	49.8	09 Power consumption P_{ed}	kW	0.69
02 Measurement category		A		09 Air flow q_v	m ³ /h	3200
03 Efficiency category		Static		09 Pressure increase p_{fs}	Pa	466
04 Efficiency grade N		77.4	62	10 Speed (rpm) n	min ⁻¹	2035
05 Variable speed drive		Yes		11 Specific ratio*		1.01

Data obtained at optimum efficiency level.

The ErP data is determined using a motor-impeller combination in a standardized measurement setup.

* Specific ratio = $1 + p_{fs} / 100\,000\text{ Pa}$

LU-184173



R3G355-RT01-M4

Stulz GmbH

EC centrifugal fan - RadiCal

backward-curved, single-intake

with guard grille

Technical description

Weight	9.5 kg
Size	355 mm
Motor size	84
Rotor surface	Painted black
Electronics housing material	Die-cast aluminum
Impeller material	PP plastic (black)
Guard grille material	Steel, phosphated and coated with black plastic (RAL 9005)
Number of blades	6
Direction of rotation	Clockwise, viewed toward rotor
Degree of protection	IP55
Insulation class	"F"
Moisture (F) / Environmental (H) protection class	H1
Max. permitted ambient temp. for motor (transport/storage)	+80 °C
Min. permitted ambient temp. for motor (transport/storage)	-40 °C
Installation position	Shaft horizontal or rotor on bottom; rotor on top on request
Condensation drainage holes	On rotor side
Mode	S1
Motor bearing	Ball bearing
Technical features	<ul style="list-style-type: none">- Output 10 VDC, max. 10 mA- Operation and alarm display- External 24 V input (parameter setting)- Alarm relay- Integrated PID controller- Motor current limitation- PFC, passive- RS-485 MODBUS-RTU- Soft start- EEPROM write cycles: 100,000 maximum- Control input 0-10 VDC / PWM- Control interface with SELV potential safely disconnected from the mains- Thermal overload protection for electronics/motor- Line undervoltage / phase failure detection
EMC immunity to interference	According to EN 61000-6-2 (industrial environment)
EMC circuit feedback	According to EN 61000-3-2/3
EMC interference emission	According to EN 61000-6-3 (household environment)
Touch current according to IEC 60990 (measuring circuit Fig. 4, TN system)	<= 3.5 mA
Electrical hookup	Connector with cable
Motor protection	Thermal overload protector (TOP) internally connected
With cable	Variable
Protection class	I (with customer connection of protective earth)
Conformity with standards	EN 61800-5-1; EN 60335-1; CE
Approval	CSA C22.2 No. 77 + CAN/CSA-E60730-1; EAC; UL 1004-7 + 60730-1



R3G355-RT01-M4

Stulz GmbH

EC centrifugal fan - RadiCal

backward-curved, single-intake
with guard grille

Product drawing

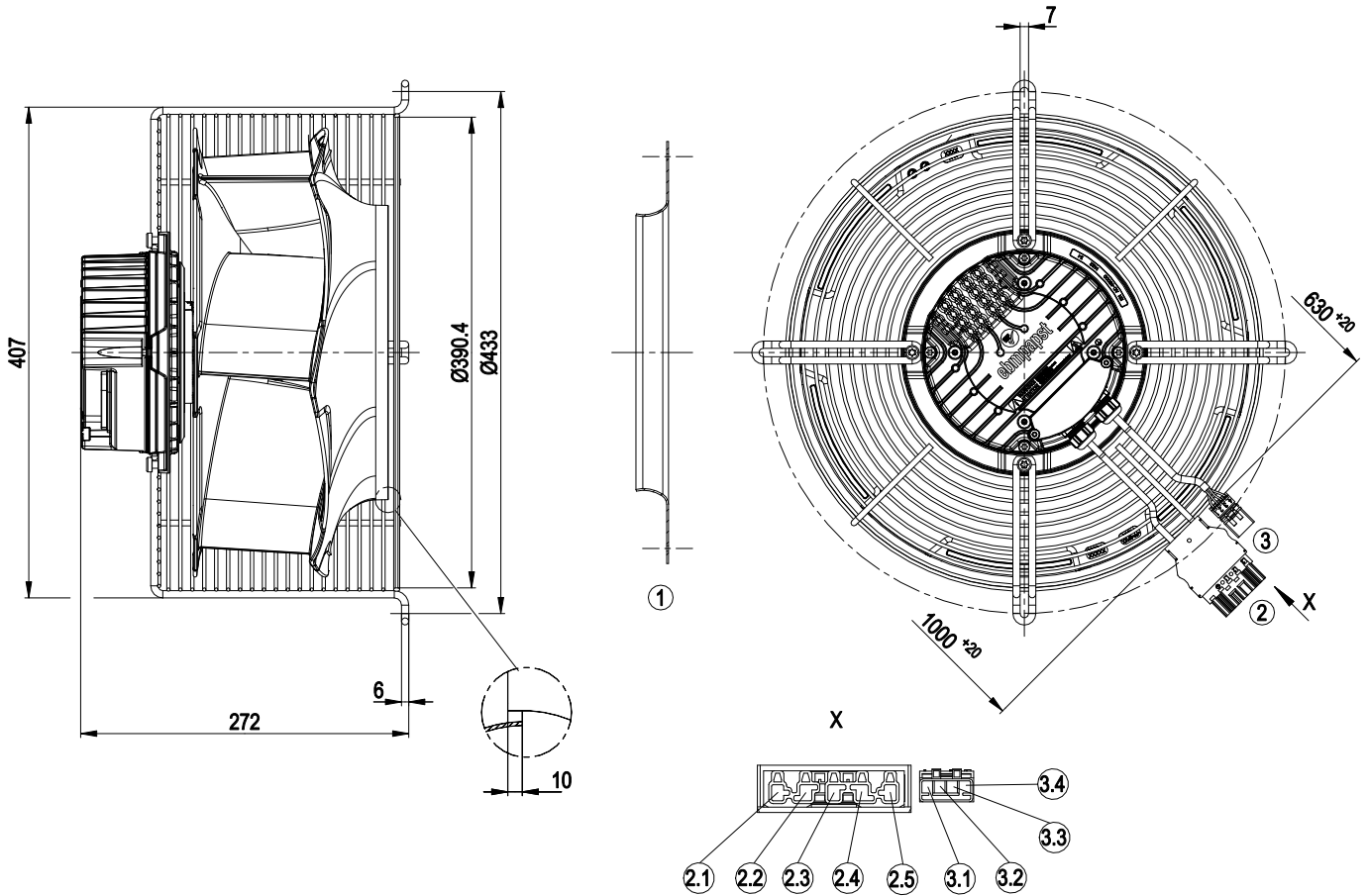

1	Accessory part: Inlet ring 35620-2-4013 not included in scope of delivery
2	Cable PVC AWG18, 5-pole connector housing WAGO 770-215 and strain relief housing WAGO 770-505/023-000
2.1	not used
2.2	PE (green/yellow)
2.3	L1 (black1)
2.4	L2 (black2)
2.5	L3 (black3)
3	Cable PVC AWG22, 4-pole connector housing WAGO WINSTA MINI 890-254
3.1	GND (blue)
3.2	0-10 VDC (yellow)
3.3	COM (white 2)
3.4	NC (white 1)



R3G355-RT01-M4

Stulz GmbH

EC centrifugal fan - RadiCal

backward-curved, single-intake

with guard grille

Accessory part

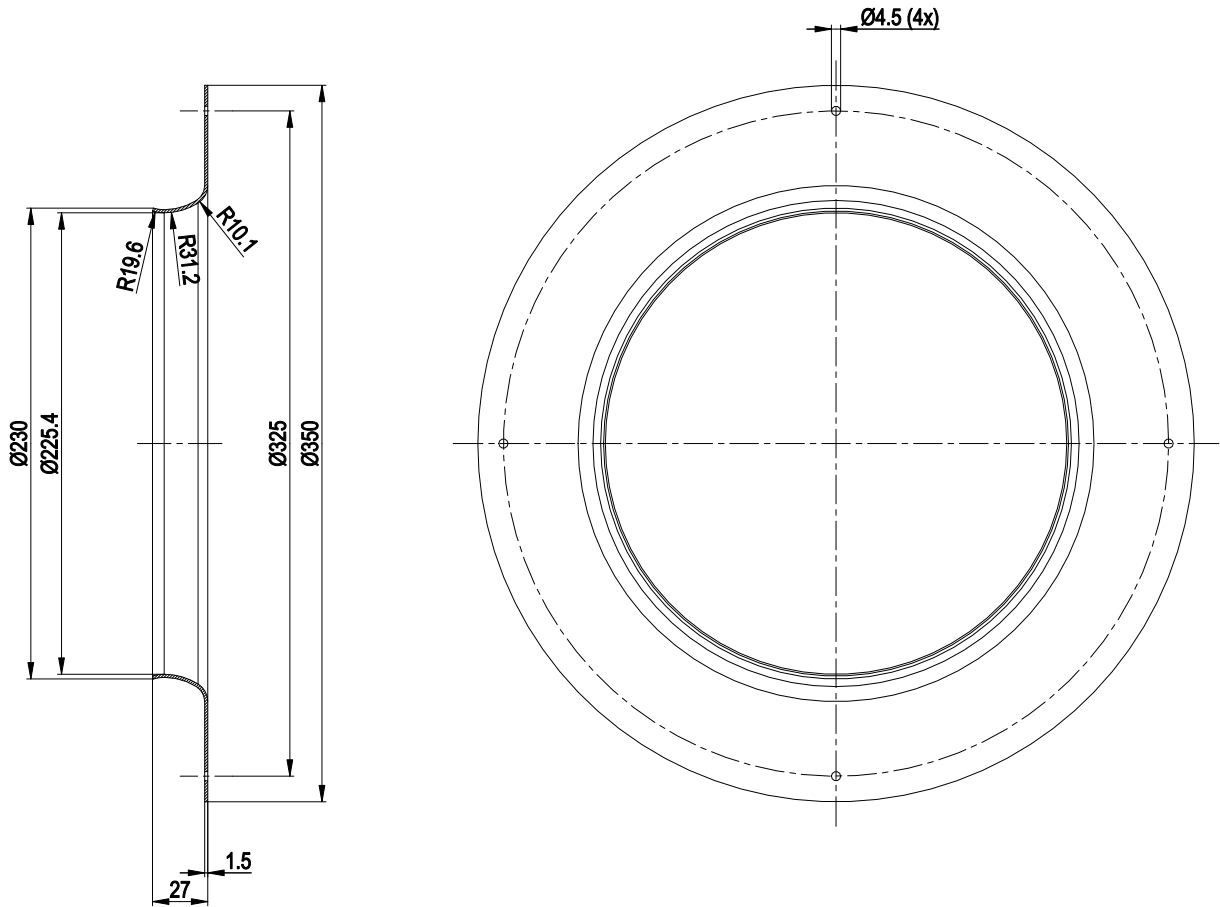

Inlet ring 35620-2-4013 not included in scope of delivery



Connection diagram

Customer circuit

adjustable speed

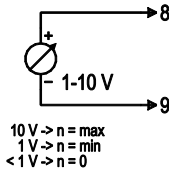

Connection

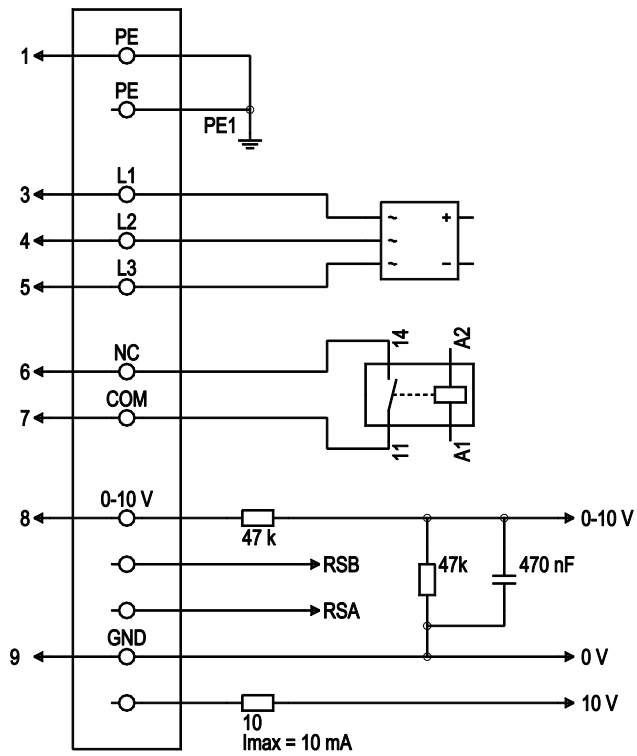

No.	Conn.	Designation	Color	Function/assignment
1	1	PE	green/yellow	Protective earth
1	3	L1	black	Power supply
1	4	L2	black	Power supply
1	5	L3	black	Power supply
2	6	NC	white 1	Status relay, floating status contact, break for failure, contact rating 250 VAC / 2 A (AC1) / min. 10 mA; reinforced insulation on supply side and basic insulation on control interface side
2	7	COM	white 2	Status relay, floating status contact, break for failure, contact rating 250 VAC / 2 A (AC1) / min. 10 mA; reinforced insulation on supply side and basic insulation on control interface side
2	8	0-10V	yellow	Analog input (set value), 0-10 V, Ri = 100 kΩ, adjustable curve, SELV
2	9	GND	blue	Reference ground for control interface, SELV



Curves: Air performance 50 Hz

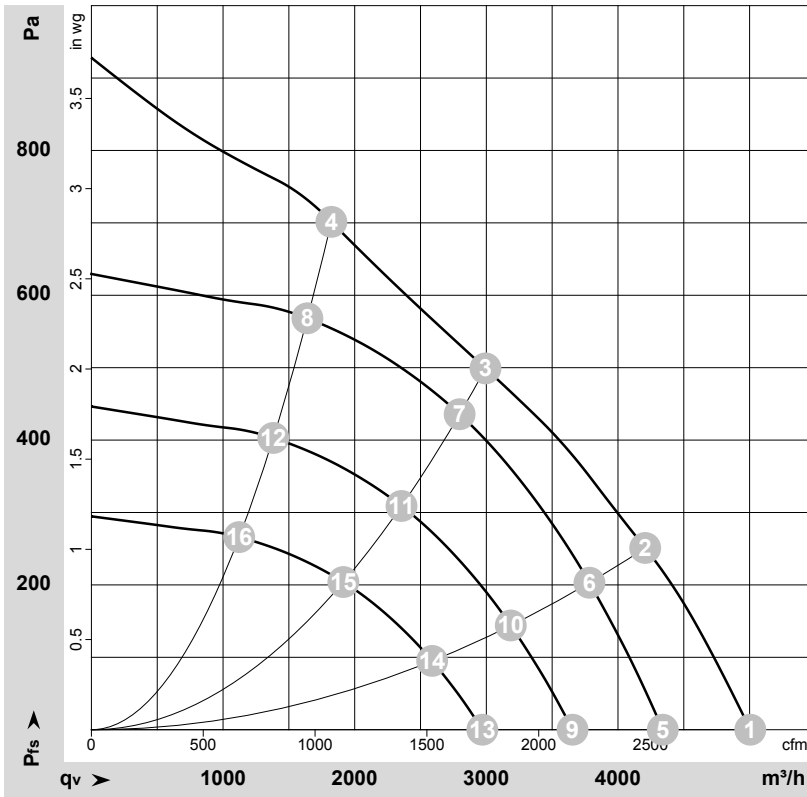

$\rho = 1.15 \text{ kg/m}^3 \pm 2 \%$

Measurement: LU-184173-1

Air performance measured according to ISO 5801 installation category A. For detailed information on the measurement setup, contact ebmpapst. Intake sound level: Sound power level according to ISO 13347 / sound pressure level measured at 1 m distance from fan axis. The values given are valid under the specified measuring conditions and may vary due to conditions of installation. For deviations from the standard configuration, the parameters have to be checked on the installed unit.

Measured values

	U	f	n	P _{ed}	I	LpA _{in}	LwA _{in}	q _v	P _{fs}	q _v	P _{fs}
	V	Hz	min ⁻¹	W	A	dB(A)	dB(A)	m ³ /h	Pa	cfm	in. wg
1	400	50	2190	594	0.94	77	84	5005	0	2945	0.00
2	400	50	2115	700	1.10	71	78	4205	250	2475	1.00
3	400	50	2100	700	1.10	66	72	2995	500	1760	2.01
4	400	50	2110	700	1.10	68	75	1825	700	1075	2.81
5	400	50	1900	387	0.61	73	80	4340	0	2555	0.00
6	400	50	1900	503	0.79	69	76	3785	203	2225	0.81
7	400	50	1900	567	0.89	64	71	2795	436	1645	1.75
8	400	50	1900	507	0.79	65	73	1640	568	965	2.28
9	400	50	1600	231	0.36	69	76	3655	0	2150	0.00
10	400	50	1600	300	0.47	64	71	3185	144	1875	0.58
11	400	50	1600	339	0.53	60	66	2355	309	1385	1.24
12	400	50	1600	303	0.47	61	68	1380	403	815	1.62
13	400	50	1300	124	0.20	64	71	2970	0	1750	0.00
14	400	50	1300	161	0.25	59	66	2590	95	1525	0.38
15	400	50	1300	182	0.28	54	61	1915	204	1125	0.82
16	400	50	1300	162	0.25	56	63	1125	266	660	1.07

U = Voltage · f = Frequency · n = Speed (rpm) · P_{ed} = Power consumption · I = Current draw · LpA_{in} = Sound pressure level intake side · LwA_{in} = Sound power level intake side
 q_v = Air flow · p_{fs} = Pressure increase

