

R3G355-RT01-I7 ebmpapst Datasheet

sales@fansco.com

www.fansco.com

Limited partnership · Headquarters Muldingen
County court Stuttgart · HRA 590344

General partner Elektrobau Muldingen GmbH · Headquarters Muldingen
County court Stuttgart · HRB 590142

Nominal data

Type	R3G355-RT01-I7	
Motor	M3G084-GF	
Phase		1~
Nominal voltage	VAC	230
Nominal voltage range	VAC	200 .. 277
Frequency	Hz	50/60
Type of data definition		ml
Speed (rpm)	min ⁻¹	2100
Power input	W	750
Current draw	A	3.3
Min. ambient temperature	°C	-25
Max. ambient temperature	°C	45

ml = Max. load · me = Max. efficiency · fa = Running at free air · cs = Customer specs · cu = Customer unit
Subject to alterations

Data in accordance with ecodesign regulation EU 327/2011

		Actual	Request 2015			
01 Overall efficiency η_{es}	%	65.8	50.2	09 Power input P_{ed}	kW	0.75
02 Measurement category		A		09 Air flow q_v	m ³ /h	3205
03 Efficiency category		Static		09 Pressure increase p_{fs}	Pa	511
04 Efficiency grade N		77.6	62	10 Speed (rpm) n	min ⁻¹	2100
05 Variable speed drive		Yes		11 Specific ratio [*]		1.01

Data definition with optimum efficiency.

The ErP data is determined using a motor-impeller combination in a standardised measurement configuration.

^{*} Specific ratio = $1 + p_{fs} / 100\,000\text{ Pa}$

LU-150482



Technical features

Mass	7 kg
Size	355 mm
Surface of rotor	Coated in black
Material of electronics housing	Die-cast aluminium, coated in black
Material of impeller	PP plastic
Number of blades	6
Direction of rotation	Clockwise, seen on rotor
Type of protection	IP 55
Insulation class	"F"
Humidity (F)/environmental protection class (H)	H2
Max. permissible ambient motor temp. (transp./ storage)	+80 °C
Min. permissible ambient motor temp. (transp./storage)	-40 °C
Mounting position	Any
Operation mode	S1
Motor bearing	Ball bearing
Technical features	<ul style="list-style-type: none"> - Output 10 VDC, max. 10 mA - Operation and alarm display - Alarm relay - Integrated PID controller - Output limit - Motor current limit - PFC, active - RS485 MODBUS RTU - Soft start - Control input 0-10 VDC / PWM - Control interface with SELV potential safely disconnected from the mains - Over-temperature protected electronics / motor - Line undervoltage / phase failure detection
Touch current acc. IEC 60990 (measuring network Fig. 4, TN system)	<= 3.5 mA
Motor protection	Thermal overload protector (TOP) wired internally
Cable exit	Variable
Protection class	I (if protective earth is connected by customer)
Product conforming to standard	EN 61800-5-1; EN 60335-1; CE
Approval	C22.2 Nr.77 + CAN/CSA-E60730-1; UL 1004-7 + 60730; EAC

Product drawing

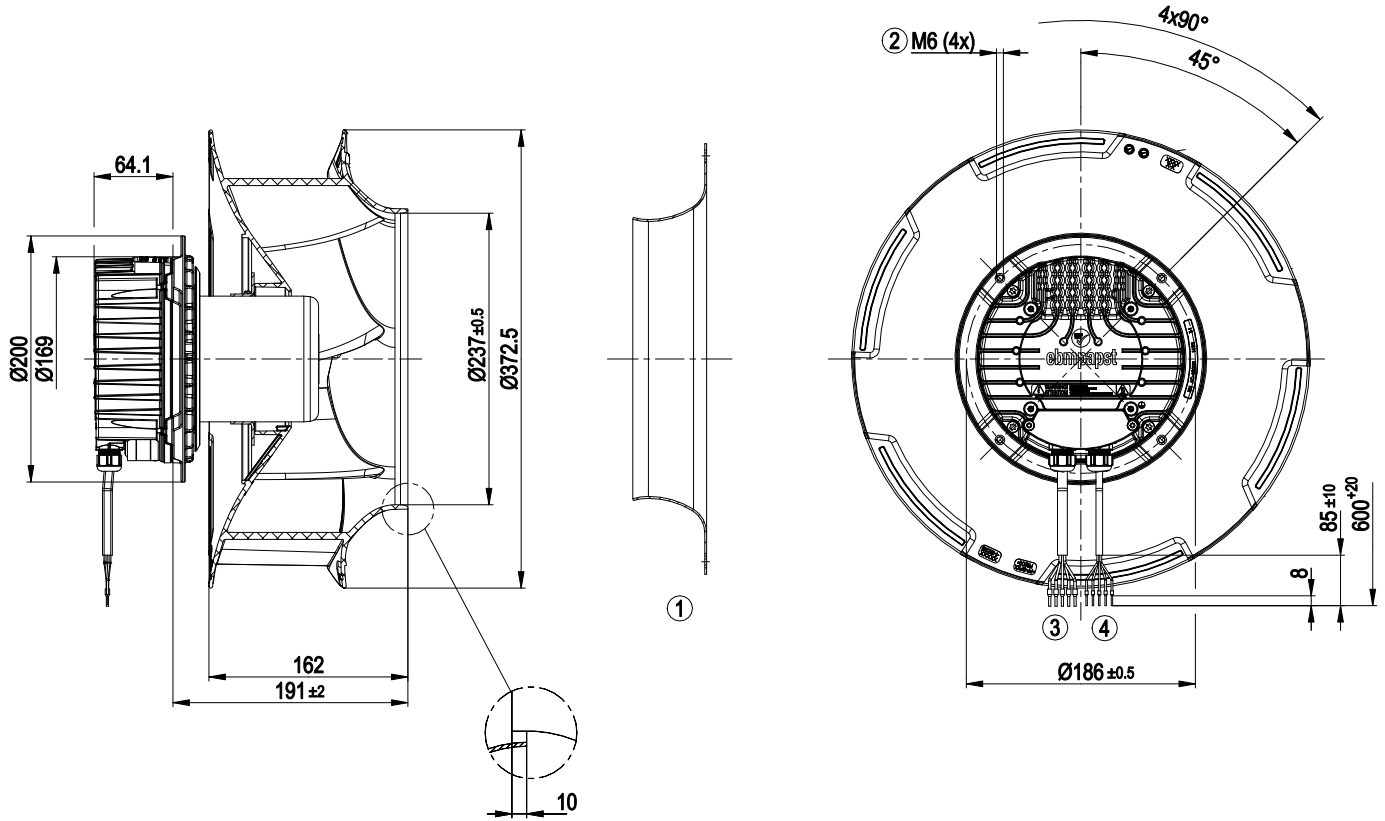

1	Accessory part: Inlet nozzle 35500-2-4013 not included in scope of delivery
2	Thread reach max. 16 mm
3	Connection line PVC AWG18, 5x crimped core-end sleeves
4	Connection line PVC AWG22, 5x crimped core-end sleeves

Accessory part

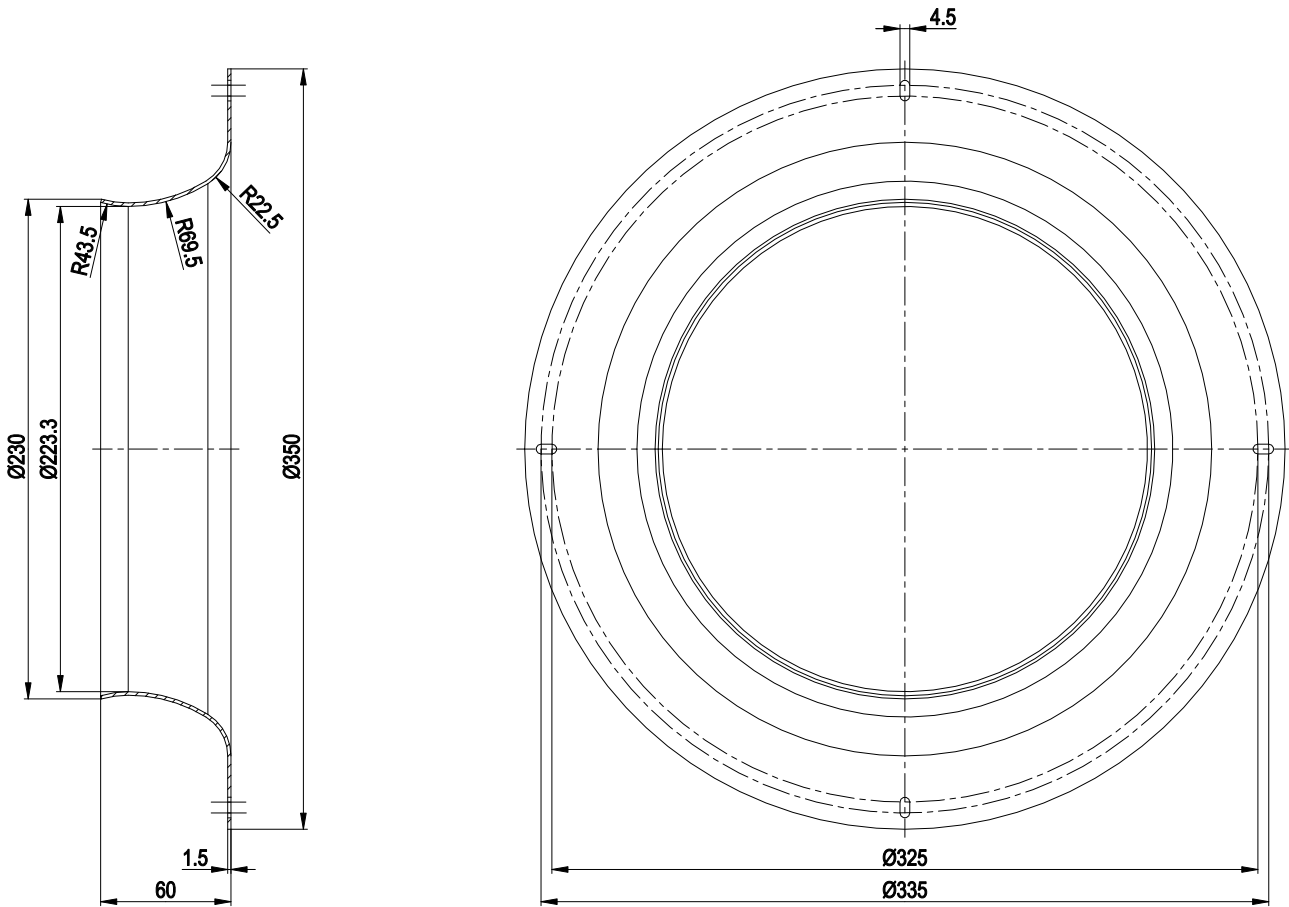

Inlet nozzle 35500-2-4013 not included in scope of delivery

Connection screen

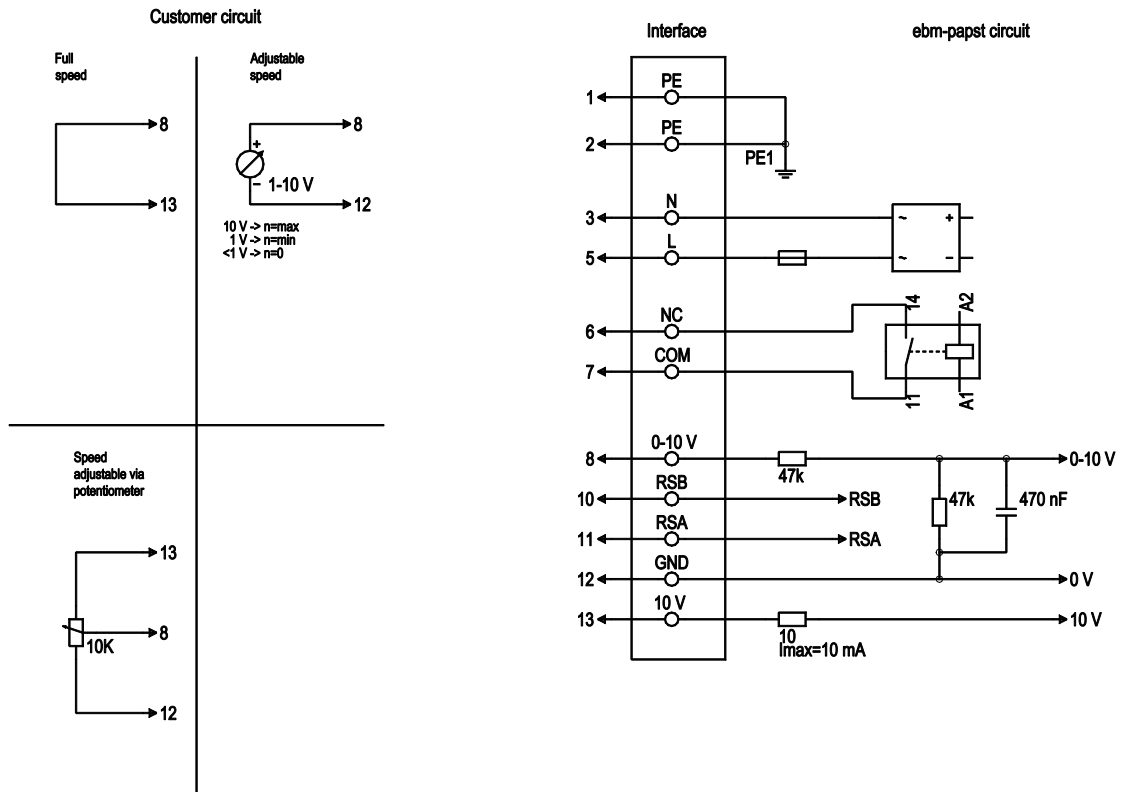

No.	Conn.	Designation	Colour	Function / assignment
1	1, 2	PE	green/yellow	Protective earth
1	3	N	blue	Supply voltage, neutral conductor, 50/60 Hz
1	5	L	black	Supply voltage, phase, 50/60 Hz
1	6	NC	white 1	Status relay, floating status contact; break for failure, contact rating 250 VAC / 2A (AC1) min. 10 mA, basic insulation on mains side and reinforced insulation on control interface side
1	7	COM	white 2	Status relay, floating status contact; common connection, contact rating 250 VAC / 2A (AC1) min. 10 mA, basic insulation on mains side and reinforced insulation on control interface side
2	8	0-10V	yellow	Analogue input 1 (set value); 0-10 V; Ri=100kΩ; parametrisable curve
2	10	RSB	brown	RS485 interface for Modbus, RSB
2	11	RSA	white	RS485 interface for Modbus, RSA
2	12	GND	blue	Reference ground for control interface, SELV
2	13	+10V	red	Fixed voltage output 10 VDC; +10 V +/-3%; max. 10 mA; short-circuit-proof; power supply for external devices (e.g. potentiometer)

Charts: Air flow 50 Hz

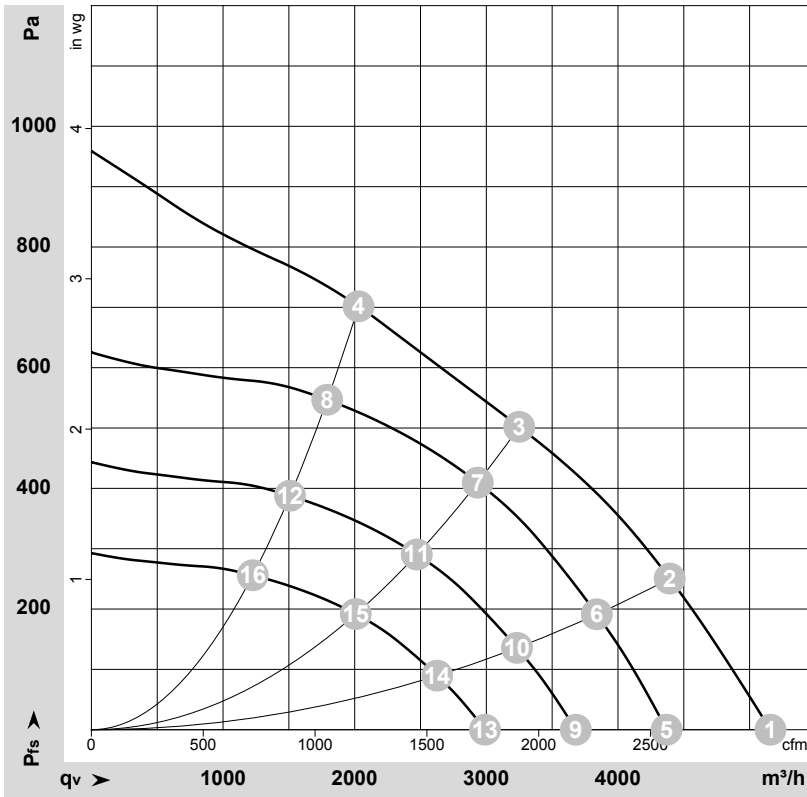

$\rho = 1.15 \text{ kg/m}^3 \pm 2 \%$

Measurement: LU-150482-1

Air performance measured as per ISO 5801 Installation category A. For detailed information on the measuring set-up, please contact ebmpapst. Suction-side noise levels: L_{wA} measured as per ISO 13347 / L_{pA} measured with 1m distance to fan axis. The values given are valid under the measuring conditions mentioned above and may vary according to the actual installation situation. With any deviation from the standard set-up, the specific values have to be checked and reviewed with the unit installed.

Measured values

	U	f	n	P _{ed}	I	L _{pA_{in}}	L _{wA_{in}}	q _v	P _{fs}	q _v	P _{fs}
	V	Hz	min ⁻¹	W	A	dB(A)	dB(A)	m³/h	Pa	cfm	inH ₂ O
1	230	50	2245	627	2.76	80	87	5160	0	3035	0.00
2	230	50	2175	750	3.30	75	82	4395	250	2585	1.00
3	230	50	2100	750	3.30	67	74	3250	500	1915	2.01
4	230	50	2155	750	3.30	68	76	2030	700	1195	2.81
5	230	50	1900	381	1.68	75	82	4370	0	2570	0.00
6	230	50	1900	502	2.20	72	79	3840	193	2260	0.77
7	230	50	1900	558	2.45	64	71	2935	410	1725	1.65
8	230	50	1900	518	2.28	65	73	1790	547	1055	2.20
9	230	50	1600	227	1.00	71	78	3680	0	2165	0.00
10	230	50	1600	300	1.32	67	74	3235	137	1905	0.55
11	230	50	1600	333	1.46	60	67	2470	291	1455	1.17
12	230	50	1600	309	1.36	61	69	1510	388	890	1.56
13	230	50	1300	122	0.54	66	73	2990	0	1760	0.00
14	230	50	1300	161	0.71	62	69	2625	90	1545	0.36
15	230	50	1300	179	0.79	55	62	2010	192	1180	0.77
16	230	50	1300	166	0.73	56	63	1225	256	720	1.03

U = Supply voltage · f = Frequency · n = Speed (rpm) · P_{ed} = Power input · I = Current draw · L_{pA_{in}} = Sound pressure level inlet side · L_{wA_{in}} = Sound power level inlet side · q_v = Air flow
P_{fs} = Pressure increase

