

R3G355-RS07-N1

EC centrifugal fan - RadiCal

backward-curved, single-intake

for rail applications



R3G355-RS07-N1 ebmpapst Datasheet

sales@fansco.com

www.fansco.com

Limited partnership · Headquarters Mulfingen

Amtsgericht (court of registration) Stuttgart · HRA 590344

General partner Elektrobau Mulfingen GmbH · Headquarters Mulfingen

Amtsgericht (court of registration) Stuttgart · HRB 590142

Nominal data

Type	R3G355-RS07-N1	
Motor	M3G084-FA	
Phase		3~
Nominal voltage	VAC	400
Nominal voltage range	VAC	380 .. 480
Frequency	Hz	50/60
Method of obtaining data		ml
Speed (rpm)	min ⁻¹	1925
Power consumption	W	580
Current draw	A	0.95
Min. ambient temperature	°C	-40
Max. ambient temperature	°C	70

ml = Max. load · me = Max. efficiency · fa = Free air · cs = Customer specification · ce = Customer equipment
Subject to change

Data according to Commission Regulation (EU) 327/2011 (EN 17166)

		Actual	Req. 2015			
01 Overall efficiency η_{es}	%	65.3	48.9	09 Power consumption P_{ed}	kW	0.56
02 Measurement category		A		09 Air flow q_v	m ³ /h	2800
03 Efficiency category		Static		09 Pressure increase p_{fs}	Pa	429
04 Efficiency grade N		78.4	62	10 Speed (rpm) n	min ⁻¹	1905
05 Variable speed drive		Yes		11 Specific ratio*		1.00

Data obtained at optimum efficiency level.

The ErP data is determined using a motor-impeller combination in a standardized measurement setup.

* Specific ratio = $1 + p_{fs} / 100\,000\text{ Pa}$

LU-178766



Technical description

Weight	7.2 kg
Size	355 mm
Motor size	84
Rotor surface	Painted black
Electronics housing material	Die-cast aluminum
Impeller material	PA plastic
Number of blades	6
Direction of rotation	Clockwise, viewed toward rotor
Degree of protection	IP55
Insulation class	"F"
Moisture (F) / Environmental (H) protection class	H3
Max. permitted ambient temp. for motor (transport/storage)	+80 °C
Min. permitted ambient temp. for motor (transport/storage)	-40 °C
Installation position	Shaft horizontal or rotor on bottom; rotor on top on request
Condensation drainage holes	On rotor side
Mode	S1
Motor bearing	Ball bearing
Technical features	<ul style="list-style-type: none"> - Output 10 VDC, max. 10 mA - Alarm relay - Integrated PID controller - Run monitoring - Power limiter - Motor current limitation - Emergency operation - PFC, passive - RS-485 MODBUS-RTU - Soft start - EEPROM write cycles: 100,000 maximum - Control input 0-10 VDC / PWM - Control interface with SELV potential safely disconnected from the mains - Overvoltage detection - Thermal overload protection for electronics/motor - Line undervoltage / phase failure detection
EMC regulations	According to EN 50121-3-2
Touch current according to IEC 60990 (measuring circuit Fig. 4, TN system)	<= 3.5 mA
Motor protection	Thermal overload protector (TOP) internally connected
With cable	Lateral
Protection class	I (with customer connection of protective earth)
Conformity with standards	EN 15085-1, CPC3: 2013; EN 45545-2, HL3: 2013; EN 50155: 2008; EN 61373, Cat. 1B: 2010; CE
Approval	EAC

EC centrifugal fan - RadiCal

backward-curved, single-intake

for rail applications

Comment

Prerequisite for operation is a Class 1 vehicle electrical system architecture according to EN 50533. If supply potential (e.g. 230 VAC) is passed through the alarm relay, the SELV signal wires lose their property of reinforced insulation, meaning they then have only basic insulation.

The SELV property (reinforced insulation) is not lost when voltages of up to 110 VDC are passed through the alarm relay. EN 50121-3-2: 2015 in preparation



EC centrifugal fan - RadiCal

backward-curved, single-intake
for rail applications

Product drawing

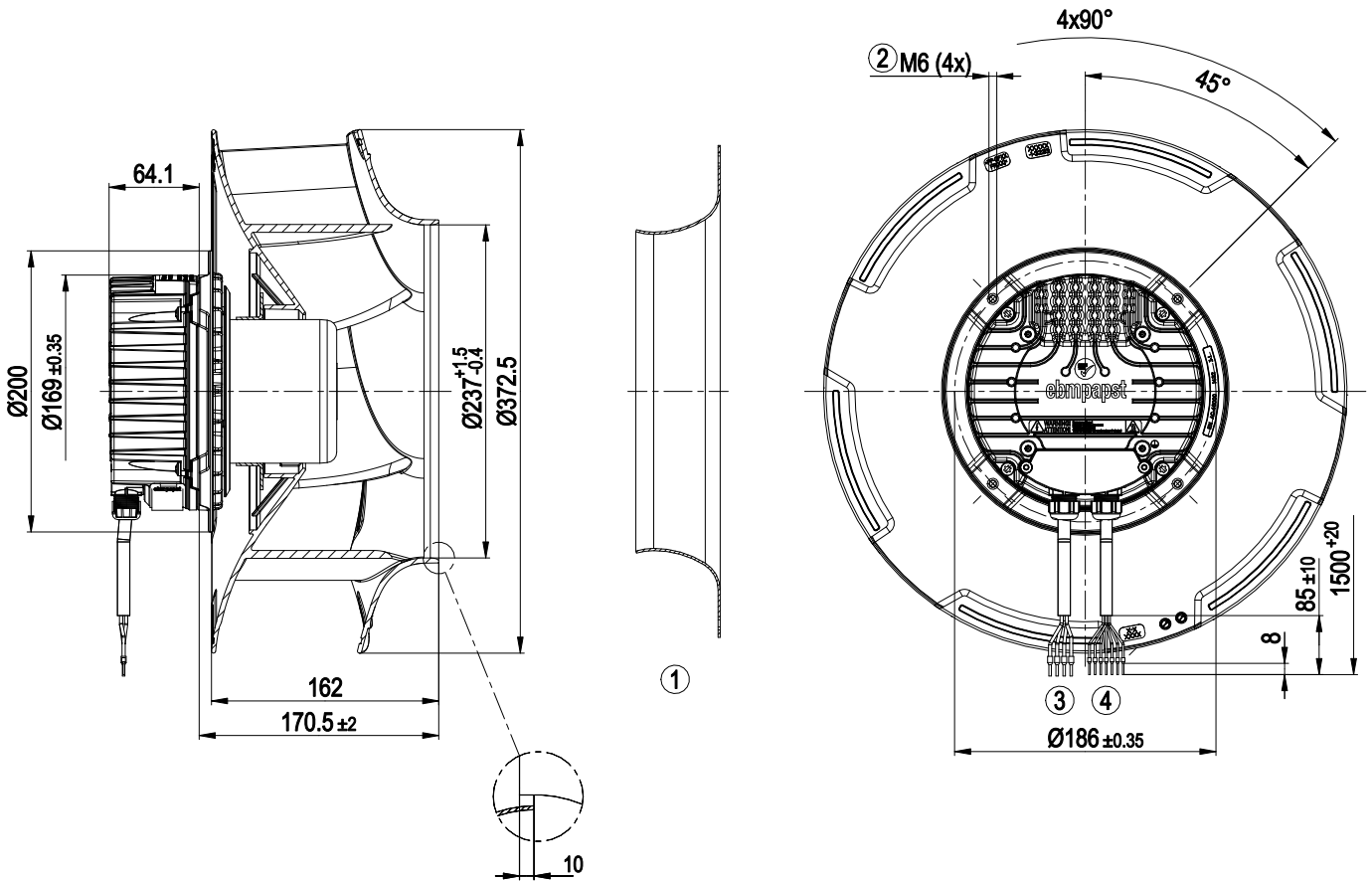

1	Accessory part: inlet ring 35500-2-4013 not included in scope of delivery
2	Max. clearance for screw 16 mm
3	Cable, halogen-free, railway application EN 45545, 4G 1.5 mm ² 4x wire-end ferrule
4	Cable, halogen-free, railway application EN 45545, 7x 0.5 mm ² 7x wire-end ferrule



EC centrifugal fan - RadiCal

backward-curved, single-intake
for rail applications

Connection diagram

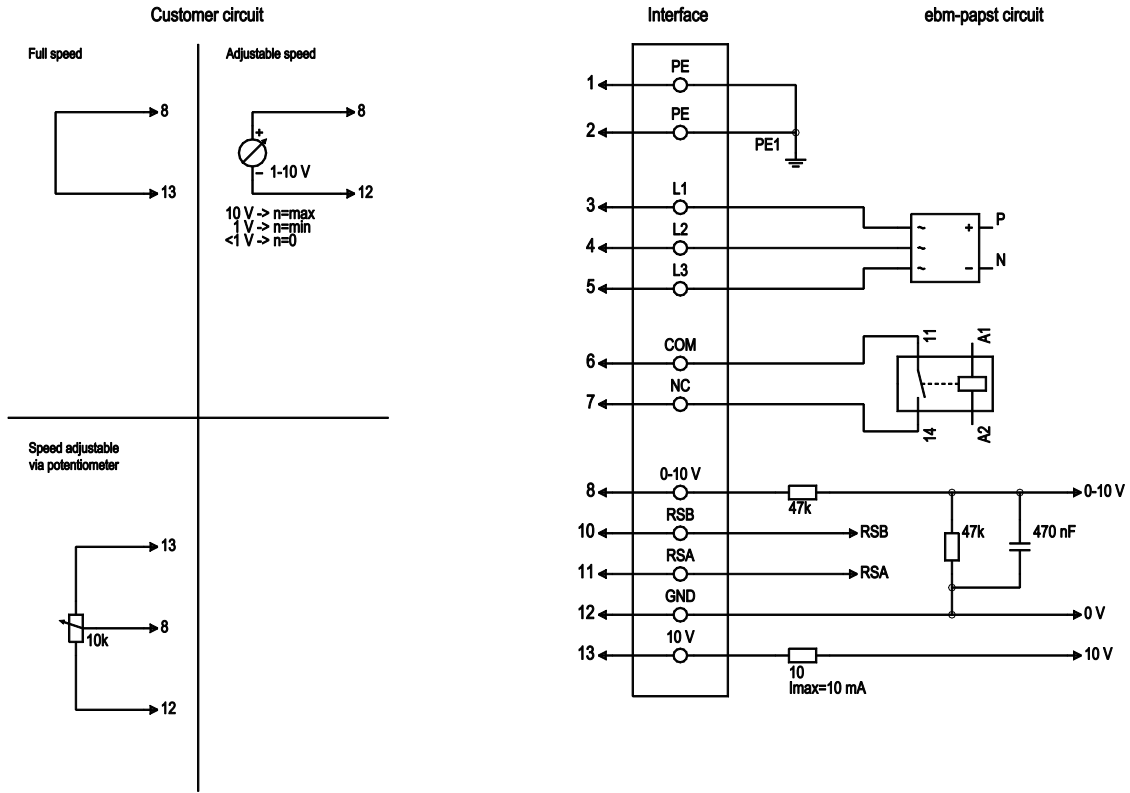

No.	Conn.	Designation	Color	Function/assignment
1	1, 2	PE	green/yellow	Protective earth
1	3	L1	black	Power supply, phase, 50/60 Hz
1	4	L2	blue	Power supply, phase, 50/60 Hz
1	5	L3	brown	Power supply, phase, 50/60 Hz
2	6	COM	gray	Status relay, floating status contact, common connection, contact rating 250 VAC / 30 VDC 5 A minimum contact separation 1 mA / 5 VDC, reinforced insulation on supply side, basic insulation on control interface side
2	7	NC	orange	Status relay, floating status contact, break for failure, contact rating 250 VAC / 30 VDC 5 A minimum contact separation 1 mA / 5 VDC, reinforced insulation on supply side, basic insulation on control interface side
2	8	0-10V	yellow	Analog input (set value) SELV, 0-10 V, Ri = 100 kΩ, adjustable curve
2	10	RSB	brown	RS485 interface for MODBUS, RSB; SELV
2	11	RSA	white	RS485 interface for MODBUS, RSA; SELV
2	12	GND	blue	Reference ground for control interface, SELV
2	13	+10V	red	Fixed voltage output 10 VDC, +10 V ± 3%, max. 10 mA, short-circuit-proof, power supply for external devices (e.g. pot); SELV



Curves: Air performance 50 Hz

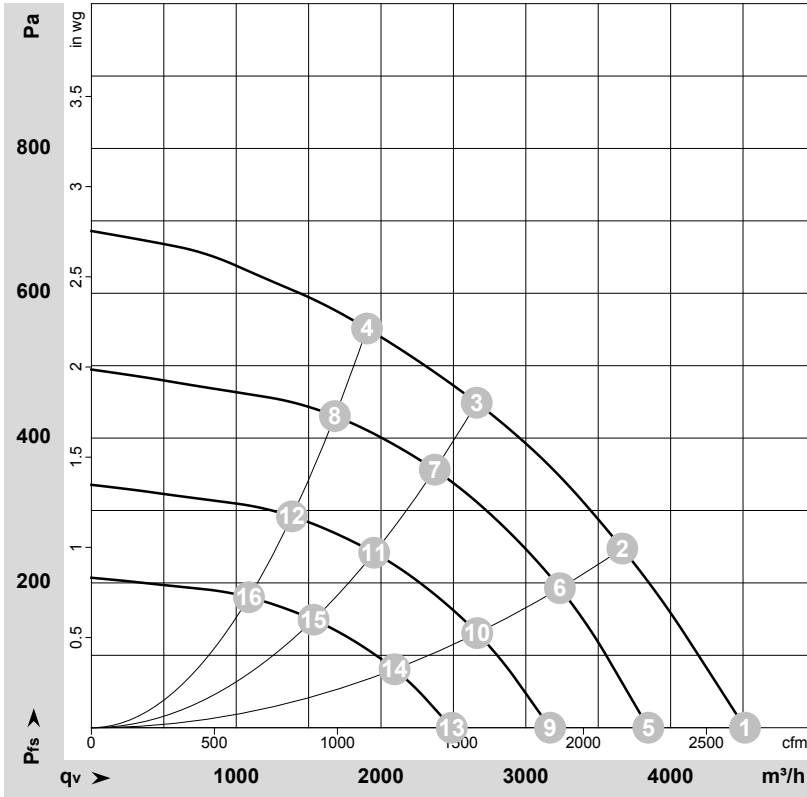

$\rho = 1.15 \text{ kg/m}^3 \pm 2 \%$

Measurement: LU-178766-1

Air performance measured according to ISO 5801 installation category A. For detailed information on the measurement setup, contact ebmpapst. Intake sound level: Sound power level according to ISO 13347 / sound pressure level measured at 1 m distance from fan axis. The values given are valid under the specified measuring conditions and may vary due to conditions of installation. For deviations from the standard configuration, the parameters have to be checked on the installed unit.

Measured values

	U	f	n	P _{ed}	I	q _v	P _{fs}	q _v	P _{fs}
	V	Hz	min ⁻¹	W	A	m ³ /h	Pa	cfm	in. wg
1	400	50	1995	437	0.75	4515	0	2655	0.00
2	400	50	1925	539	0.90	3665	250	2160	1.00
3	400	50	1925	580	0.95	2660	450	1565	1.81
4	400	50	1925	541	0.90	1905	550	1120	2.21
5	400	50	1700	270	0.47	3845	0	2265	0.00
6	400	50	1700	371	0.62	3235	194	1905	0.78
7	400	50	1700	398	0.66	2370	357	1395	1.43
8	400	50	1700	374	0.62	1680	431	990	1.73
9	400	50	1400	151	0.26	3165	0	1865	0.00
10	400	50	1400	207	0.35	2665	131	1570	0.53
11	400	50	1400	222	0.37	1955	242	1150	0.97
12	400	50	1400	209	0.35	1385	292	815	1.17
13	400	50	1100	73	0.13	2490	0	1465	0.00
14	400	50	1100	101	0.17	2095	81	1230	0.33
15	400	50	1100	108	0.18	1535	149	905	0.60
16	400	50	1100	101	0.17	1090	180	640	0.72

U = Voltage · f = Frequency · n = Speed (rpm) · P_{ed} = Power consumption · I = Current draw · q_v = Air flow · p_s = Pressure increase

