

R3G355-HA34-01 ebmpapst Datasheet
 sales@fansco.com
 www.fansco.com

Limited partnership · Headquarters Muldingen
 Amtsgericht (court of registration) Stuttgart · HRA 590344
 General partner Elektrobau Muldingen GmbH · Headquarters Muldingen
 Amtsgericht (court of registration) Stuttgart · HRB 590142

Nominal data

Type	R3G355-HA34-01	
Motor	M3G150-FF	
Phase		3~
Nominal voltage	VAC	400
Nominal voltage range	VAC	380 .. 480
Frequency	Hz	50/60
Method of obtaining data		ml
Status		prelim.
Speed (rpm)	min ⁻¹	4100
Power consumption	W	4700
Current draw	A	7.2
Min. ambient temperature	°C	-40
Max. ambient temperature	°C	50

ml = Max. load · me = Max. efficiency · fa = Free air · cs = Customer specification · ce = Customer equipment
 Subject to change

Data according to Commission Regulation (EU) 327/2011

		Actual	Req. 2015			
01 Overall efficiency η_{es}	%	59	58.5	09 Power consumption P_{ed}	kW	4.63
02 Measurement category		A		09 Air flow q_v	m ³ /h	5020
03 Efficiency category		Static		09 Pressure increase p_{fs}	Pa	1899
04 Efficiency grade N		62.5	62	10 Speed (rpm) n	min ⁻¹	4130
05 Variable speed drive		Yes		11 Specific ratio [*]		1.02

Data obtained at optimum efficiency level.
 The ErP data is determined using a motor-impeller combination in a standardized measurement setup.

^{*} Specific ratio = $1 + p_{fs} / 100\,000\text{ Pa}$

LU-192675



Technical description

Weight	0.001 kg
Size	355 mm
Motor size	150
Rotor surface	Painted black
Electronics housing material	Die-cast aluminum
Impeller material	Sheet aluminum
Number of blades	6
Direction of rotation	Clockwise, viewed toward rotor
Degree of protection	IP55
Insulation class	"F"
Moisture (F) / Environmental (H) protection class	H1
Ambient temperature note	Occasional start-up at temperatures between -40°C and -25°C is permitted. For continuous operation at ambient temperatures below -25°C (such as refrigeration applications), use must be made of a fan design with special low-temperature bearings.
Max. permitted ambient temp. for motor (transport/storage)	+80 °C
Min. permitted ambient temp. for motor (transport/storage)	-40 °C
Installation position	Shaft horizontal or rotor on bottom; rotor on top on request
Condensation drainage holes	On rotor side
Mode	S1
Motor bearing	Ball bearing
Technical features	<ul style="list-style-type: none"> - Output 10 VDC, max. 10 mA - Output for slave 0-10 V - External 24 V input (parameter setting) - External release input - Alarm relay - Integrated PID controller - Power limiter - Motor current limitation - PFC, passive - RS-485 MODBUS-RTU - Soft start - Control input 0-10 VDC - Control interface with SELV potential safely disconnected from the mains - Thermal overload protection for electronics/motor - Line undervoltage / phase failure detection
Touch current according to IEC 60990 (measuring circuit Fig. 4, TN system)	<= 3.5 mA
Electrical hookup	Terminal box
Motor protection	Reverse polarity and locked-rotor protection
Protection class	I (with customer connection of protective earth)
Conformity with standards	EN 61800-5-1; CE
Approval	CSA C22.2 No. 77 + CAN/CSA-E60730-1; EAC; UL 1004-7 + 60730-1



Product drawing

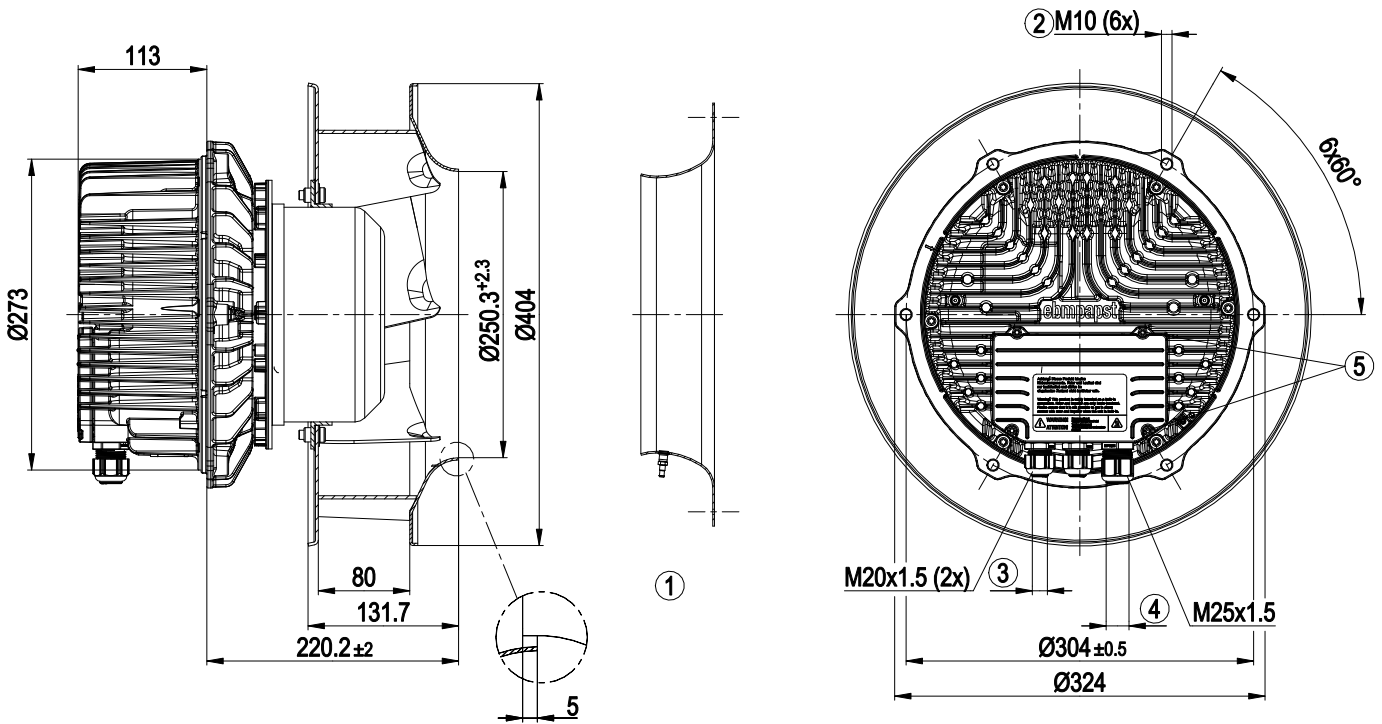

1	Accessory part: Inlet ring 35675-2-4013 with pressure tap (k-factor: 148) not included in scope of delivery
2	Max. clearance for screw 20 mm
3	Cable diameter min. 4 mm, max. 10 mm, tightening torque 4 ± 0.6 Nm
4	Cable diameter min. 9 mm, max. 16 mm, tightening torque 6 ± 0.9 Nm
5	Tightening torque 3.5 ± 0.5 Nm



Accessory part

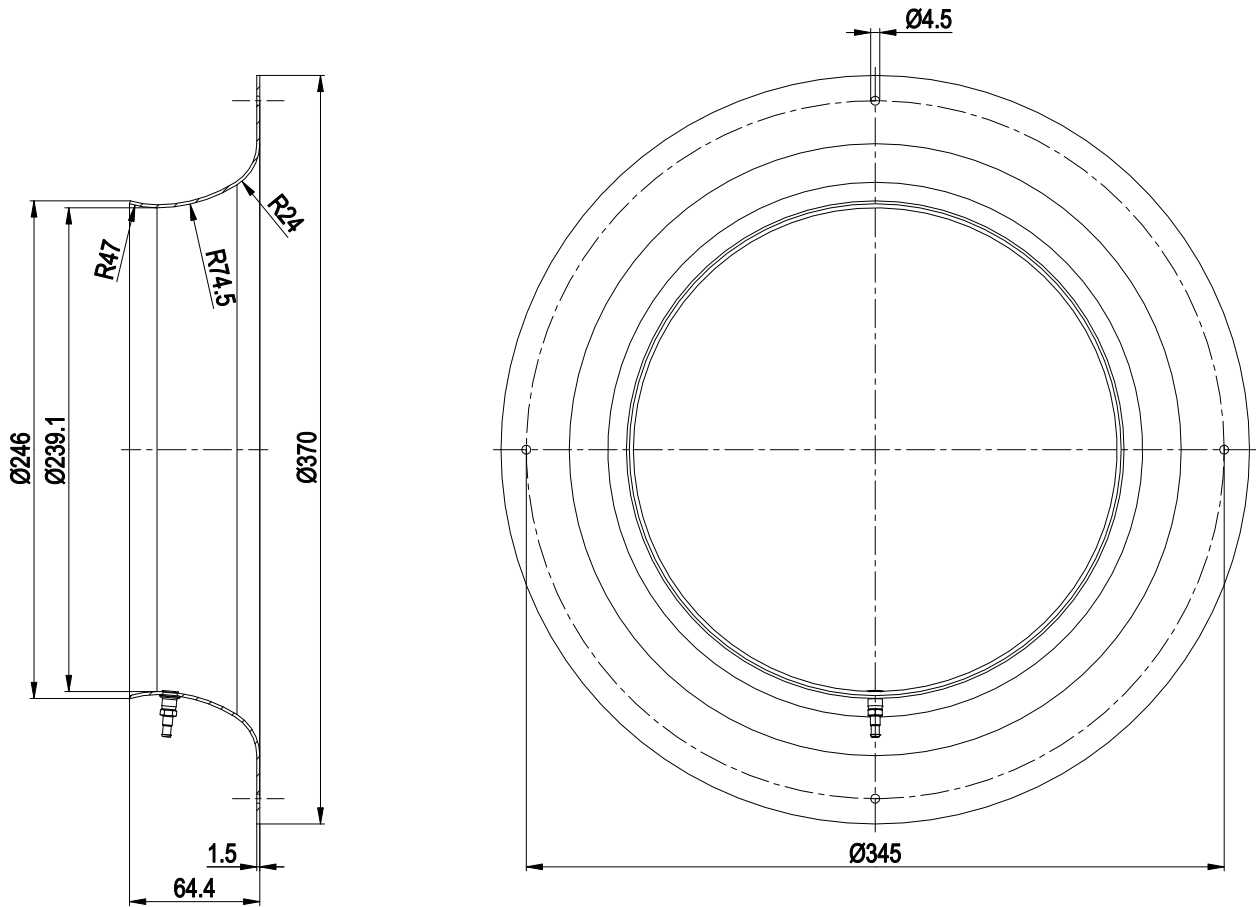

Inlet ring 35675-2-4013 with pressure tap (k-factor: 148)



Connection diagram

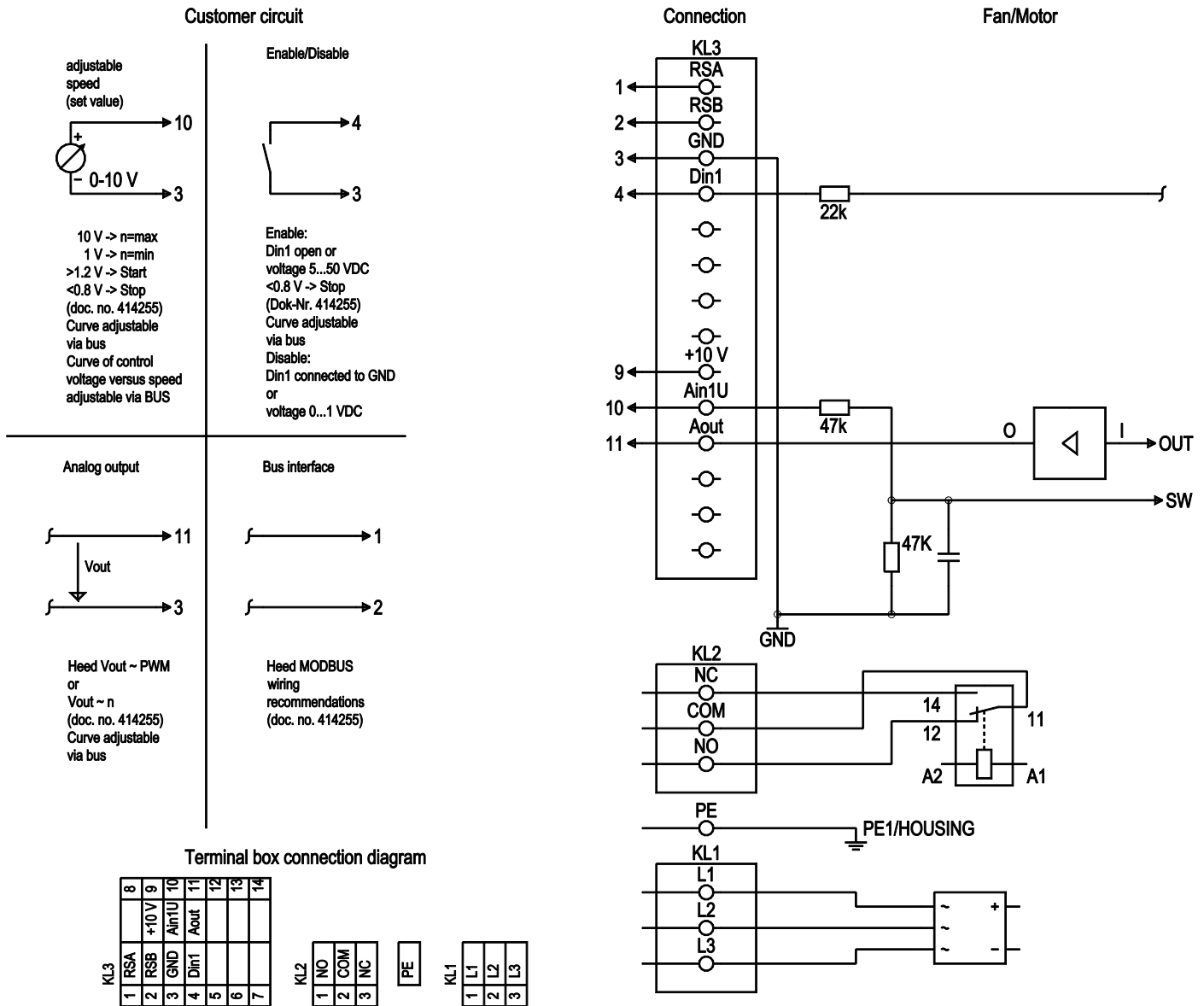

No.	Conn.	Designation	Function/assignment
KL 1	1, 2, 3	L1, L2, L3	Power supply, phase, see nameplate for voltage range
PE	PE	PE	Protective earth
KL2	1	NO	Status relay, floating status contact, option 1: make for failure, option 2: make for error for run monitor
KL2	2	COM	Status relay, floating status contact, common connection, contact rating 250 VAC / 2 A (AC1) / min. 10 mA; basic insulation on supply side and reinforced insulation on control interface side
KL2	3	NC	Status relay, floating status contact, option 1: break for failure, option 2: break for error message for run monitor
KL 3	1	RSA	RS485 interface for MODBUS, RSA; SELV
KL 3	2	RSB	RS485 interface for MODBUS, RSB; SELV
KL 3	3	GND	Reference ground for control interface; SELV
KL 3	4	Din1	Digital input 1: enable electronics, enable: pin open or applied voltage 5-50 VDC voltage < 1 VDC Set and a level change to < 1 VDC; SELV



No.	Conn.	Designation	Function/assignment
KL 3	-	-	-
KL 3	-	-	-
KL3	-	-	-
KL3	-	-	-
KL 3	9	10 V / max. 10 mA	Voltage output, power supply for external devices (e.g. potentiometers), SELV
KL 3	10	Ain1 U	Analog input 1, set value: 0-10 V, Ri = 100 kΩ, adjustable curve; SELV
KL 3	11	Aout	Analog output 0-10 VDC, max. 5 mA, output of current motor modulation level / motor speed adjustable curve; SELV
KL 3	-	-	-
KL 3	-	-	-
KL 3	-	-	-



Curves: Air performance 50 Hz

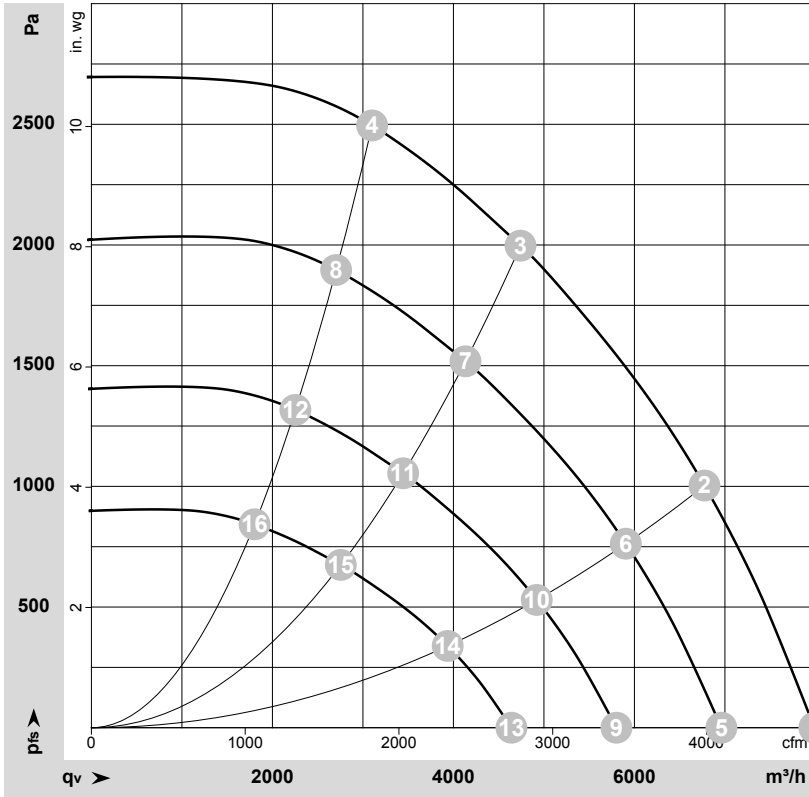

$\rho = 1.15 \text{ kg/m}^3 \pm 2 \%$

Measurement: LU-192675-1

Air performance measured according to ISO 5801 installation category A. For detailed information on the measurement setup, contact ebmpapst. Intake sound level: Sound power level according to ISO 13347 / sound pressure level measured at 1 m distance from fan axis. The values given are valid under the specified measuring conditions and may vary due to conditions of installation. For deviations from the standard configuration, the parameters have to be checked on the installed unit.

Measured values

	Wired	U	f	n	P _{ed}	I	LpA _{in}	LwA _{in}	LwA _{out}	q _v	p _{fs}	q _v	p _{fs}
		V	Hz	min ⁻¹	W	A	dB(A)	dB(A)	dB(A)	m ³ /h	Pa	cfm	in. wg
1	3~	400	50	4100	2895	4.56	93	100	107	7990	0	4700	0.00
2	3~	400	50	4100	3944	6.13	87	95	103	6775	1000	3985	4.01
3	3~	400	50	4100	4700	7.20	86	93	101	4740	2000	2790	8.03
4	3~	400	50	4100	4478	6.89	92	99	103	3100	2500	1825	10.04
5	3~	400	50	3600	1916	3.02	89	96	104	6960	0	4095	0.00
6	3~	400	50	3600	2612	4.06	84	91	99	5905	765	3475	3.07
7	3~	400	50	3600	3093	4.75	82	90	97	4135	1518	2435	6.09
8	3~	400	50	3600	2967	4.56	89	96	99	2705	1897	1590	7.62
9	3~	400	50	3000	1109	1.75	85	92	99	5800	0	3415	0.00
10	3~	400	50	3000	1512	2.35	79	87	95	4920	532	2895	2.14
11	3~	400	50	3000	1790	2.75	78	85	93	3445	1054	2025	4.23
12	3~	400	50	3000	1717	2.64	84	91	95	2255	1318	1325	5.29
13	3~	400	50	2400	568	0.89	79	86	93	4640	0	2730	0.00
14	3~	400	50	2400	774	1.20	74	81	89	3935	340	2315	1.36
15	3~	400	50	2400	916	1.41	72	80	87	2755	675	1620	2.71
16	3~	400	50	2400	879	1.35	79	86	89	1805	843	1060	3.38

Wired = Wiring · U = Voltage · f = Frequency · n = Speed (rpm) · P_{ed} = Power consumption · I = Current draw · LpA_{in} = Sound pressure level intake side · LwA_{in} = Sound power level intake side · LwA_{out} = Sound power level outlet side · q_v = Air flow · p_{fs} = Pressure increase

