

R3G355-AZ59-05 ebmpapst Datasheet

sales@fansco.com

www.fansco.com

Limited partnership · Headquarters Mulfingen

Amtsgericht (court of registration) Stuttgart · HRA 590344

General partner Elektrobau Mulfingen GmbH · Headquarters Mulfingen

Amtsgericht (court of registration) Stuttgart · HRB 590142



## Nominal data

Type	R3G355-AZ59-05	
Motor	M3G112-EA	
Phase		3~
Nominal voltage	VAC	400
Nominal voltage range	VAC	380 .. 480
Frequency	Hz	50/60
Method of obtaining data		ml
Speed (rpm)	min <sup>-1</sup>	2800
Power consumption	W	1500
Current draw	A	2.4
Min. ambient temperature	°C	-25
Max. ambient temperature	°C	60

ml = Max. load · me = Max. efficiency · fa = Free air · cs = Customer specification · ce = Customer equipment  
Subject to change

## Data according to ErP Directive

		Actual	Req. 2015			
01 Overall efficiency $\eta_{es}$	%	60.7	53	09 Power consumption $P_{ed}$	kW	1.38
02 Measurement category		A		09 Air flow $q_v$	m <sup>3</sup> /h	3210
03 Efficiency category		Static		09 Pressure increase $p_{fs}$	Pa	873
04 Efficiency grade N		69.7	62	10 Speed (rpm) $n$	min <sup>-1</sup>	2770
05 Variable speed drive		Yes		11 Specific ratio <sup>*</sup>		1.01

Data obtained at optimum efficiency level.

The ErP data is determined using a motor-impeller combination in a standardized measurement setup.

<sup>\*</sup> Specific ratio =  $1 + p_{fs} / 100\,000\text{ Pa}$

LU-129227



## Technical description

Weight	11.3 kg
Fan size	355 mm
Rotor surface	Painted black
Electronics housing material	Die-cast aluminum
Impeller material	Sheet aluminum
Number of blades	7
Direction of rotation	Clockwise, viewed toward rotor
Degree of protection	IP54
Insulation class	"B"
Moisture (F) / Environmental (H) protection class	F4-1
Max. permitted ambient temp. for motor (transport/storage)	+80 °C
Min. permitted ambient temp. for motor (transport/storage)	-40 °C
Installation position	Shaft horizontal or rotor on bottom; rotor on top on request
Condensation drainage holes	On rotor side
Mode	S1
Motor bearing	Ball bearing
Technical features	<ul style="list-style-type: none"> <li>- Output 10 VDC, max. 10 mA</li> <li>- Output 20 VDC, max. 50 mA</li> <li>- Output for slave 0-10 V</li> <li>- Operation and alarm display</li> <li>- Input for sensor 0-10 V or 4-20 mA</li> <li>- External 24 V input (parameter setting)</li> <li>- External release input</li> <li>- Alarm relay</li> <li>- Integrated PID controller</li> <li>- Motor current limitation</li> <li>- PFC, passive</li> <li>- RS-485 MODBUS-RTU, 8-bit version</li> <li>- Soft start</li> <li>- Control input 0-10 VDC / PWM</li> <li>- Control interface with SELV potential safely disconnected from the mains</li> <li>- Thermal overload protection for electronics/motor</li> <li>- Line undervoltage / phase failure detection</li> </ul>
EMC immunity to interference	According to EN 61000-6-2 (industrial environment)
EMC interference emission	According to EN 61000-6-3 (household environment)
Touch current according to IEC 60990 (measuring circuit Fig. 4, TN system)	<= 3.5 mA
Electrical hookup	With plug; Via terminal box
Motor protection	Thermal overload protector (TOP) internally connected
With cable	Variable
Protection class	I (with customer connection of protective earth)
Approval	CSA C22.2 No. 100; UL 1004-1

# EC centrifugal fan

backward-curved, single-intake

## Product drawing

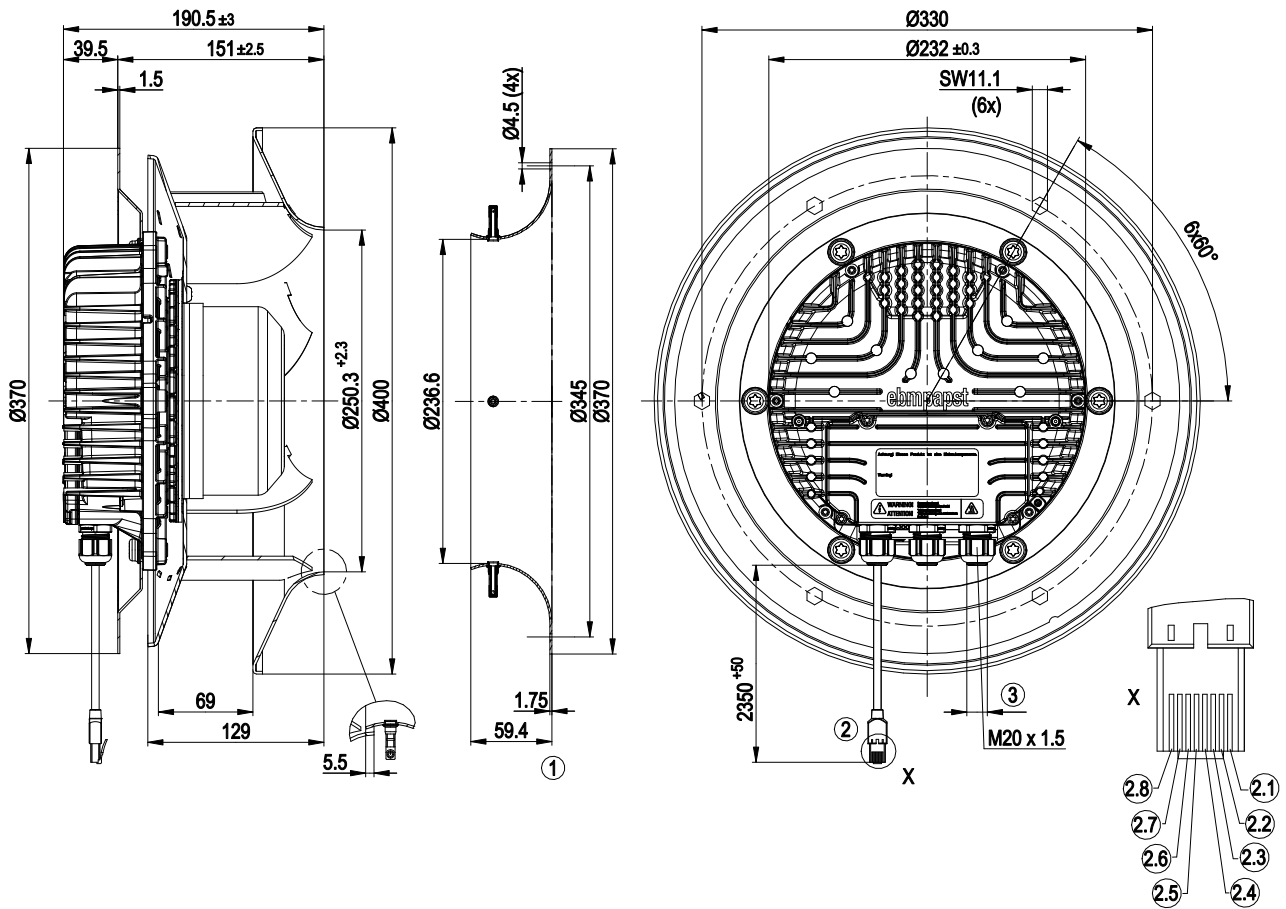

1	Accessory parts: Inlet ring with piezometer 35530-6-4013 and inlet ring 35550-2-4013 not included in scope of delivery
2	Control cable PVC with plug RJ-45 (8 contacts)
2.1	Ain1 U
2.2	GND
2.3	Aout
2.4	GND
2.5	COM
2.6	NC
2.7	RSA
2.8	RSB
3	Cable diameter min. 4 mm, max. 10 mm, tightening torque $4 \pm 0.6$ Nm



## Connection diagram

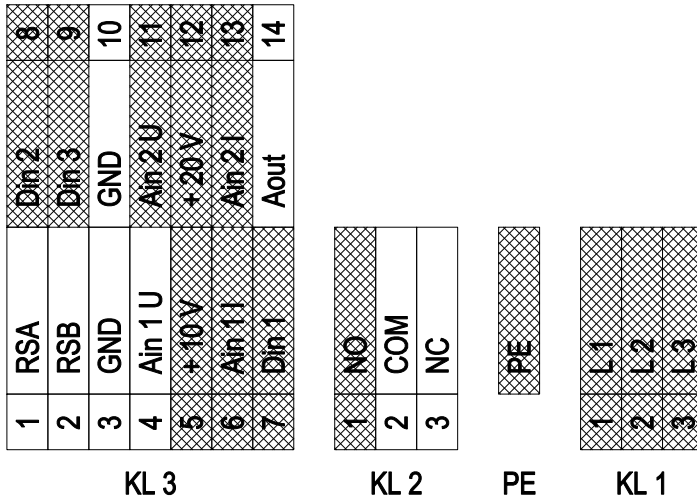

shaded gray => not brought out via leads

No.	Conn.	Designation	Function/assignment
KL 1	1	L1	Supply connection, power supply 3-phase 380-480 VAC; 50/60 Hz
KL 1	2	L2	Supply connection, power supply 3-phase 380-480 VAC; 50/60 Hz
KL 1	3	L3	Supply connection, power supply 3-phase 380-480 VAC; 50/60 Hz
PE		PE	Ground connection, PE connection
KL 2	1	NO	Status relay, floating status contact; make for failure
KL2	2	COM	Status relay; floating status contact; changeover contact; common connection; contact rating 250 VAC/ max. 2 A (AC1)/min. 10 mA
KL2	3	NC	Status relay, floating status contact; break for failure
KL 3	1	RSA	Bus connection RS485; RSA; MODBUS RTU
KL 3	2	RSB	Bus connection RS485; RSB; MODBUS RTU
KL 3	3 / 10	GND	Reference ground for control interface
KL 3	4	Ain1 U	Analog input 1 (set value); 0-10 V; Ri = 100 kΩ; adjustable curves; only usable as alternative to input Ain1 I
KL 3	5	+ 10 V	Fixed voltage output 10 VDC; + 10 V +/-3 %; max. 10 mA; short-circuit-proof; power supply for ext. devices (e.g. potentiometers)
KL 3	6	Ain1 I	Analog input 1 (set value); 4-20 mA, Ri = 100 Ω; adjustable curves; only usable as alternative to input Ain1 U
KL 3	7	Din1	Digital input 1: Enable electronics; Enable: Pin open or applied voltage 5...50 VDC; Disable: Bridge to GND or applied voltage < 1 VDC; Reset function: Triggers software reset after a level change to <1 V
KL 3	8	Din2	Digital input 2: Switching parameter sets 1/2; according to EEPROM setting, the valid or used parameter set can be selected via bus or via digital input DIN2. Parameter set 1: Pin open or applied voltage 5...50 VDC; Parameter set 2: Bridge to GND or applied voltage < 1 VDC
KL 3	9	Din3	Digital input 3: Direction of action of integrated controller; Depending on EEPROM setting, the direction of action of the integrated controller can be selected as normal/inverse via bus or digital input; Normal: Pin open or applied voltage 5...50 VDC; Inverse: Bridge to GND or applied voltage < 1 VDC
KL 3	11	Ain2 U	Analog input 2; measured value 0-10 V; Ri = 100 kΩ; adjustable curve; only usable as alternative to input Ain2 I
KL 3	12	+ 20 V	Fixed voltage output 20 VDC; + 20 V +25/-10%; max. 50 mA; short-circuit-proof power supply for ext. devices (e.g. sensors)
KL 3	13	Ain2 I	Analog input 2; measured value: 4-20 mA; Ri = 100 Ω; adjustable curve; only usable as alternative to input Ain2 U



# EC centrifugal fan

backward-curved, single-intake

No.	Conn.	Designation	Function/assignment
KL 3	14	Aout	Analog output 0-10 V; max. 5 mA; output of current motor modulation level/current motor speed.



## Curves: Air performance 50 Hz

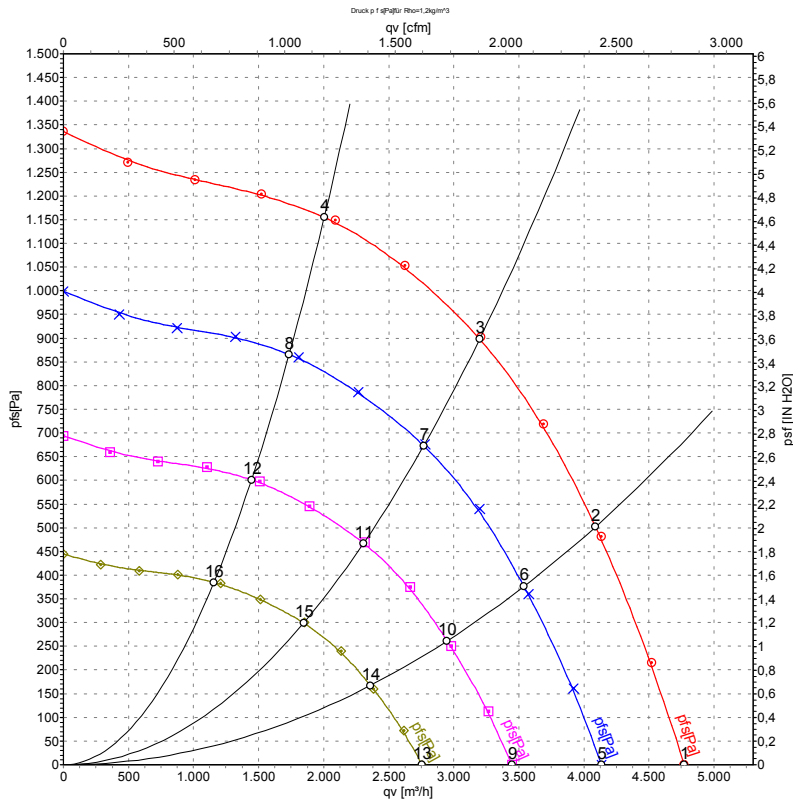

Measurement: LU-129227-1

Air performance measured according to ISO 5801 installation category A. For detailed information on the measurement setup, contact ebmpapst. Intake sound level: Sound power level according to ISO 13347 / sound pressure level measured at 1 m distance from fan axis. The values given are valid under the specified measuring conditions and may vary due to conditions of installation. For deviations from the standard configuration, the parameters have to be checked on the installed unit.

## Measured values

	U	f	n	P <sub>ed</sub>	I	qv	p <sub>fs</sub>	qv	p <sub>fs</sub>
	V	Hz	min <sup>-1</sup>	W	A	m <sup>3</sup> /h	Pa	CFM	inH2O
1	400	50	2800	888	1.44	4770	0	2810	0.00
2	400	50	2800	1234	1.95	4085	500	2405	2.01
3	400	50	2800	1500	2.40	3200	900	1880	3.61
4	400	50	2800	1270	2.02	2005	1150	1180	4.62
5	400	50	2400	578	0.94	4135	0	2435	0.00
6	400	50	2400	799	1.26	3540	379	2080	1.52
7	400	50	2400	895	1.41	2770	679	1630	2.73
8	400	50	2400	824	1.31	1735	867	1020	3.48
9	400	50	2000	335	0.54	3445	0	2030	0.00
10	400	50	2000	462	0.73	2950	263	1735	1.06
11	400	50	2000	518	0.82	2305	471	1360	1.89
12	400	50	2000	477	0.76	1445	602	850	2.42
13	400	50	1600	171	0.28	2755	0	1625	0.00
14	400	50	1600	237	0.37	2360	168	1390	0.67
15	400	50	1600	265	0.42	1845	302	1085	1.21
16	400	50	1600	244	0.39	1155	386	680	1.55

U = Power supply · f = Frequency · n = Speed (rpm) · P<sub>ed</sub> = Power consumption · I = Current draw · qv = Air flow · p<sub>fs</sub> = Pressure increase

