

R3G355-AN51-32 ebmpapst Datasheet

sales@fansco.com

www.fansco.com

Limited partnership · Headquarters Muldingen
County court Stuttgart · HRA 590344

General partner Elektrobau Muldingen GmbH · Headquarters Muldingen
County court Stuttgart · HRB 590142



Nominal data

Type	R3G355-AN51-32	
Motor	M3G084-FA	
Nominal voltage	VDC	48
Nominal voltage range	VDC	36 .. 57
Type of data definition		fa
Speed	min ⁻¹	1600
Power input	W	300
Current draw	A	6.3
Min. ambient temperature	°C	- 25
Max. ambient temperature	°C	+ 60

ml = max. load · me = max. efficiency · fa = running at free air · cs = customer specs · cu = customer unit
Subject to alterations

Data according to ErP directive

Installation category	A
Efficiency category	Static
Variable speed drive	Yes
Specific ratio*	1.00

* Specific ratio = $1 + p_b / 100\,000\text{ Pa}$

	Actual	Request 2013	Request 2015
Overall efficiency η_{es}	62	42.4	46.4
Efficiency grade N	77.6	58	62
Power input P_e	kW	0.33	
Air flow q_v	m ³ /h	1910	
Pressure increase p_{fs}	Pa	351	
Speed n	min ⁻¹	1600	

Data established at point of optimum efficiency



Technical features

Mass	4.88 kg
Size	355 mm
Surface of rotor	Coated in black
Material of impeller	Sheet aluminium, laser-welded
Number of blades	6
Direction of rotation	Clockwise, seen on rotor
Type of protection	IP 42
Insulation class	"B"
Max. permissible ambient motor temp. (transp./ storage)	+80 °C
Min. permissible ambient motor temp. (transp./storage)	-40 °C
Mounting position	Shaft horizontal or rotor on top; rotor on bottom on request
Condensate discharge holes	None
Operation mode	S1
Motor bearing	Ball bearing
Technical features	<ul style="list-style-type: none"> - Control input 0-10 VDC / PWM - Tach output - Over-temperature protected motor
EMC interference immunity	Acc. to EN 61000-6-2
EMC interference emission	Acc. to EN 55022 (Class B)
Motor protection	Thermal overload protector (TOP) wired internally
Cable exit	Variable
Product conforming to standard	EN 60950-1
Approval	UL 1004-1; CSA C22.2 Nr.100

Product drawing

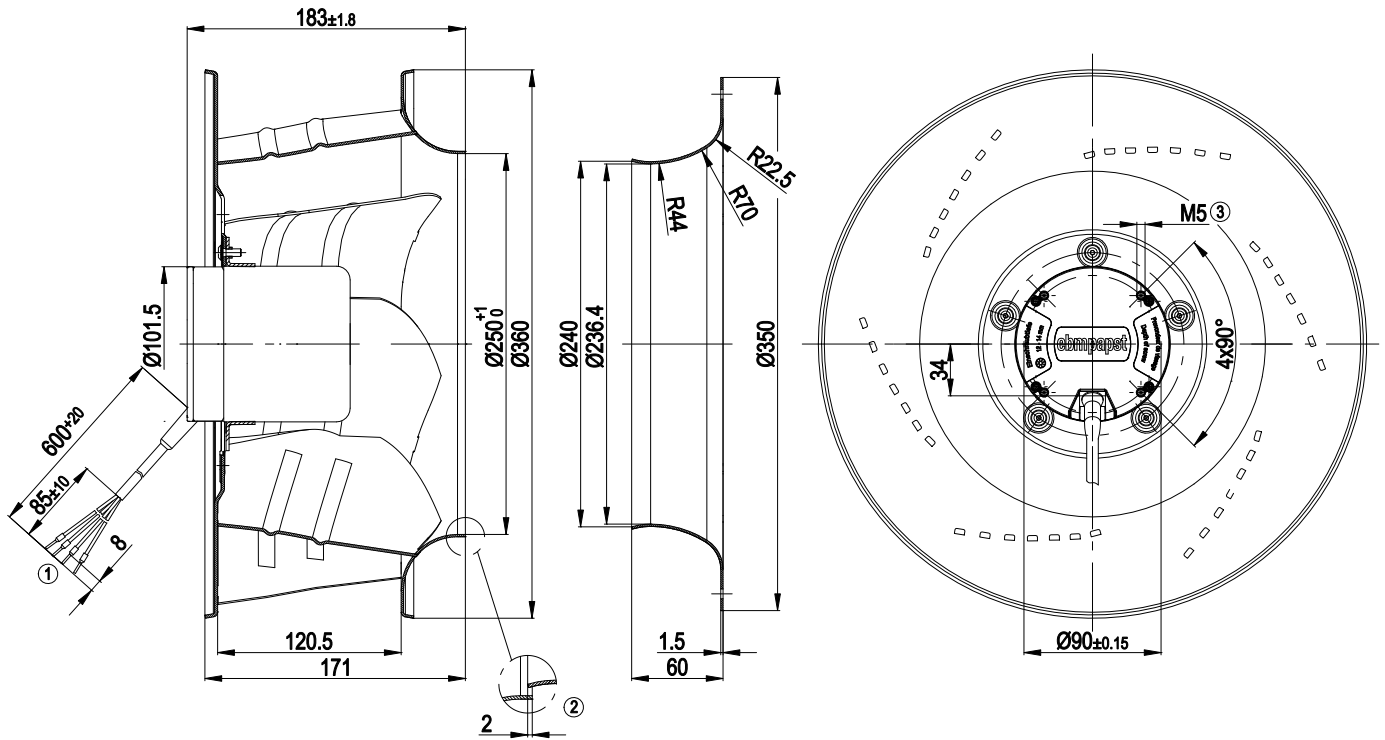

1	Connecting line AWG16, 4 x crimped core-end sleeves
2	Accessory part: Inlet nozzle 35560-2-4013 not included in delivery, other inlet nozzles on request
3	Depth of screw 12-14 mm

EC centrifugal fan

backward curved, single inlet

Connection screen

Customer circuit

Notes on various control possibilities and their applications

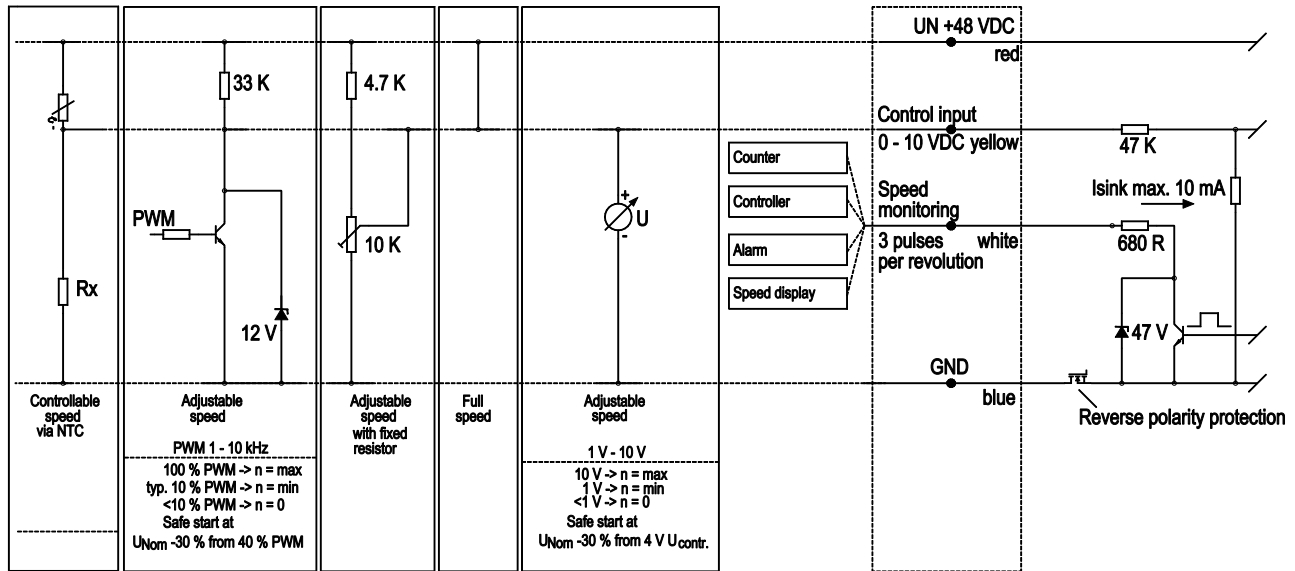

Charts: Air flow

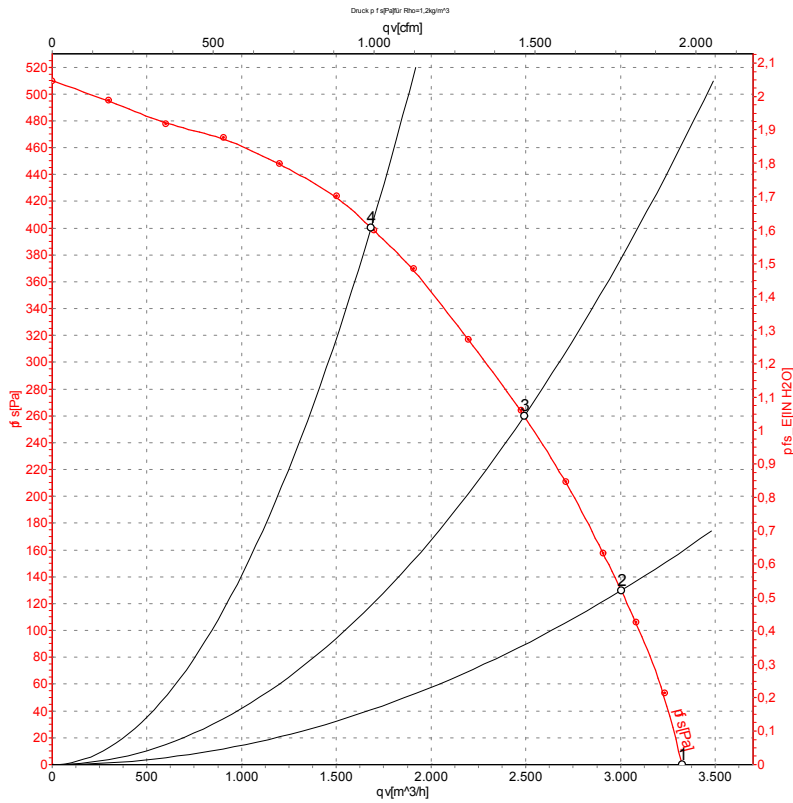

Measurement: LU-115629

Air performance measured as per ISO 5801 Installation category A. For detailed information on the measuring set-up, please contact ebm-papst. Suction-side noise levels: LwA measured as per ISO 13347 / LpA measured with 1m distance to fan axis. The values given are valid under the measuring conditions mentioned above and may vary according to the actual installation situation. With any deviation from the standard set-up, the specific values have to be checked and reviewed with the unit installed.

Measured values

	U	n	P _{ed}	I	qv	p _{fs}
	V	min ⁻¹	W	A	m ³ /h	Pa
1	48	1610	268	5.64	3325	0
2	48	1605	322	6.77	3005	130
3	48	1600	350	7.30	2490	260
4	48	1610	327	6.87	1685	400

U = Supply voltage · n = Speed · P_{ed} = Power input · I = Current draw · qv = Air flow · p_{fs} = Pressure increase

