

R3G355-AN37-81 ebmpapst Datasheet

sales@fansco.com

www.fansco.com

Limited partnership · Headquarters Muldingen

Amtsgericht (court of registration) Stuttgart · HRA 590344

General partner Elektrobau Muldingen GmbH · Headquarters Muldingen

Amtsgericht (court of registration) Stuttgart · HRB 590142

Nominal data

Type	R3G355-AN37-81	
Motor	M3G084-FA	
Phase		1~
Nominal voltage	VAC	115
Nominal voltage range	VAC	100 .. 130
Method of obtaining data		ml
Speed (rpm)	min ⁻¹	1500
Power consumption	W	320
Current draw	A	3.7
Min. ambient temperature	°C	-25
Max. ambient temperature	°C	60

ml = Max. load · me = Max. efficiency · fa = Free air · cs = Customer specification · ce = Customer equipment
Subject to change



Technical description

Weight	5.9 kg
Fan size	355 mm
Rotor surface	Painted black
Electronics housing material	Die-cast aluminum
Impeller material	Sheet aluminum
Number of blades	6
Direction of rotation	Clockwise, viewed toward rotor
Degree of protection	IP54
Insulation class	"B"
Moisture (F) / Environmental (H) protection class	F3-1
Max. permitted ambient temp. for motor (transport/storage)	+80 °C
Min. permitted ambient temp. for motor (transport/storage)	-40 °C
Installation position	Shaft horizontal or rotor on top; rotor on bottom on request
Condensation drainage holes	None
Mode	S1
Motor bearing	Ball bearing
Technical features	<ul style="list-style-type: none"> - Output 10 VDC, max. 1.1 mA - Alarm relay - Motor current limitation - Soft start - Control input 0-10 VDC / PWM - Control interface with SELV potential safely disconnected from the mains - Thermal overload protection for electronics/motor - Line undervoltage detection
Touch current according to IEC 60990 (measuring circuit Fig. 4, TN system)	<= 3.5 mA
Motor protection	Thermal overload protector (TOP) internally connected
With cable	Variable
Protection class	I (with customer connection of protective earth)
Conformity with standards	EN 61800-5-1
Approval	UL 2111; CSA C22.2 No. 77; EAC

Product drawing

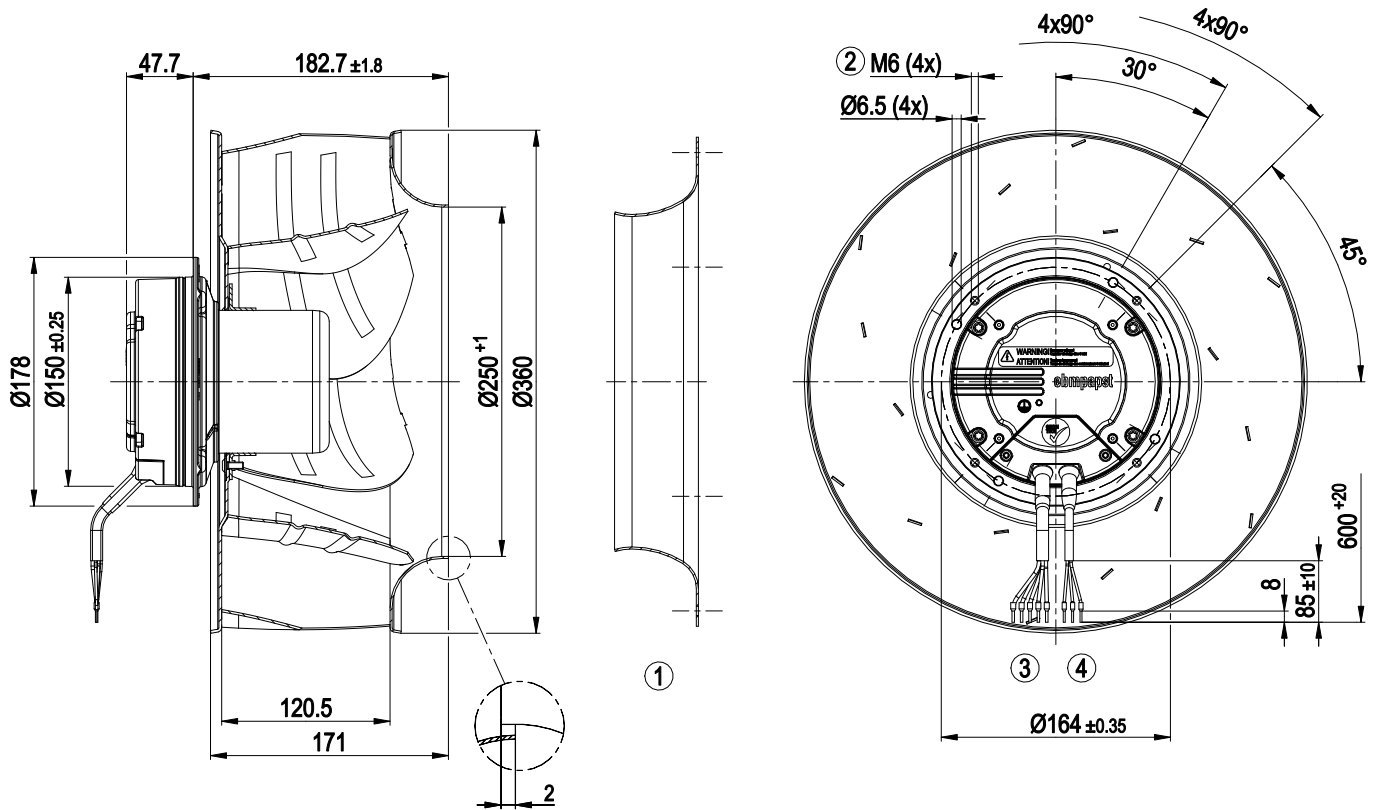

1	Accessory part: Inlet ring 35560-2-4013 not included in scope of delivery, other inlet rings on request
2	Max. clearance for screw 10 mm
3	Cable PVC AWG18, 5x crimped ferrules
4	Cable PVC AWG22, 3x crimped ferrules



EC centrifugal fan

backward-curved, single-intake

Accessory part

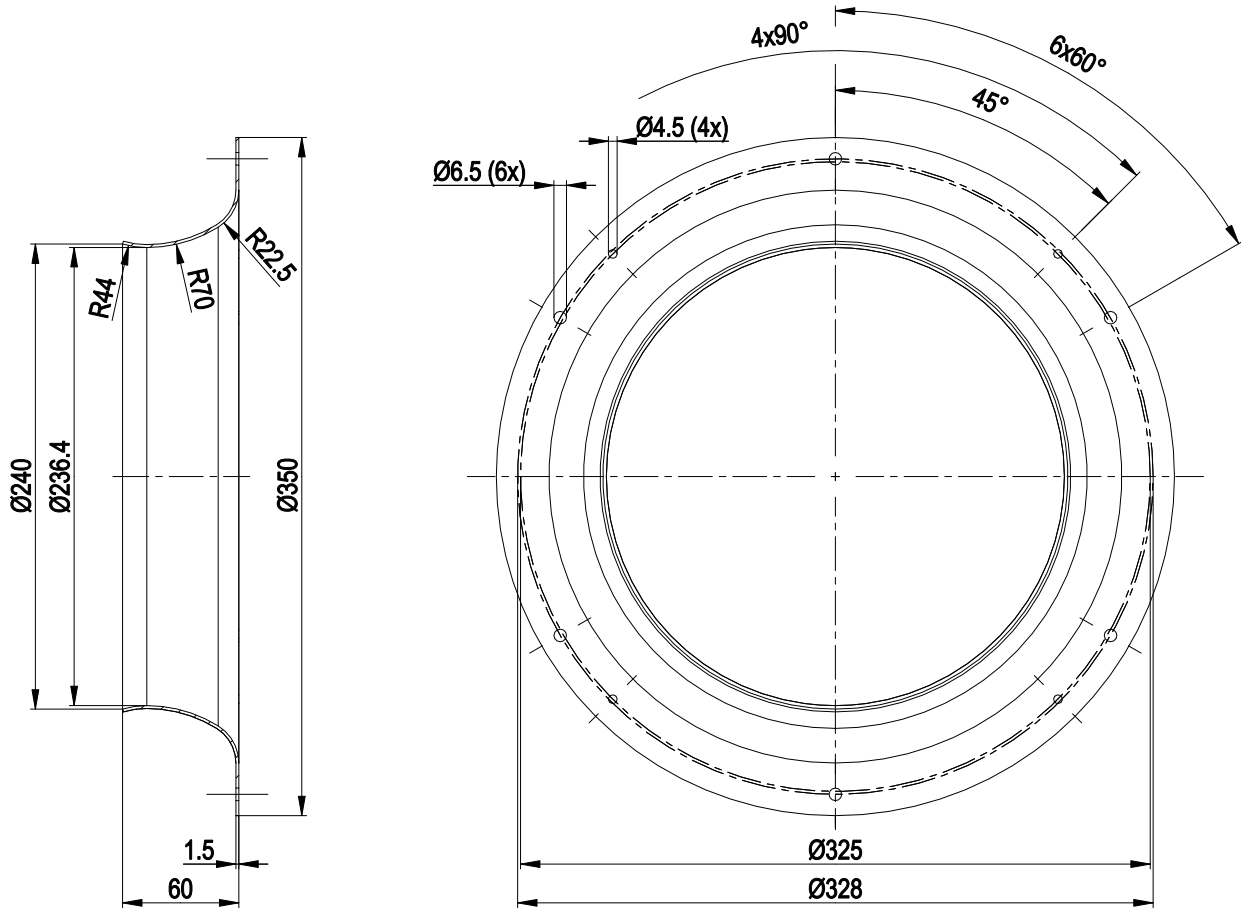

EC centrifugal fan

backward-curved, single-intake

Connection diagram

Customer circuit

Application notes for various control options

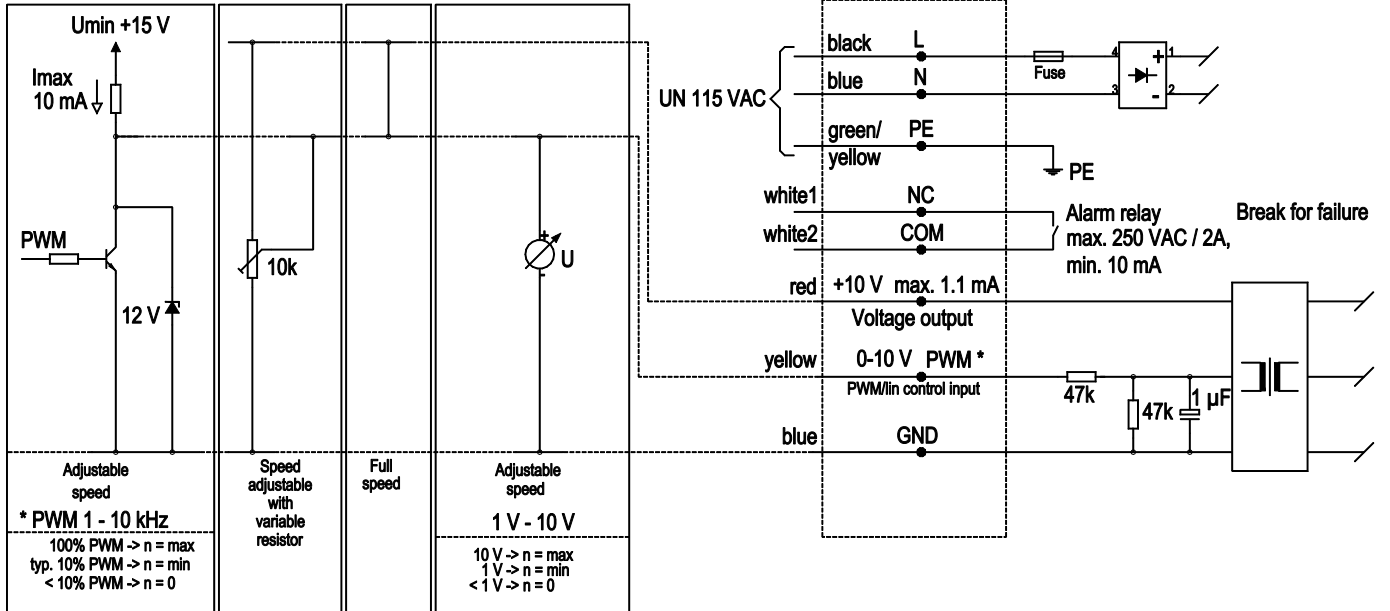

Curves: Air performance 50 Hz

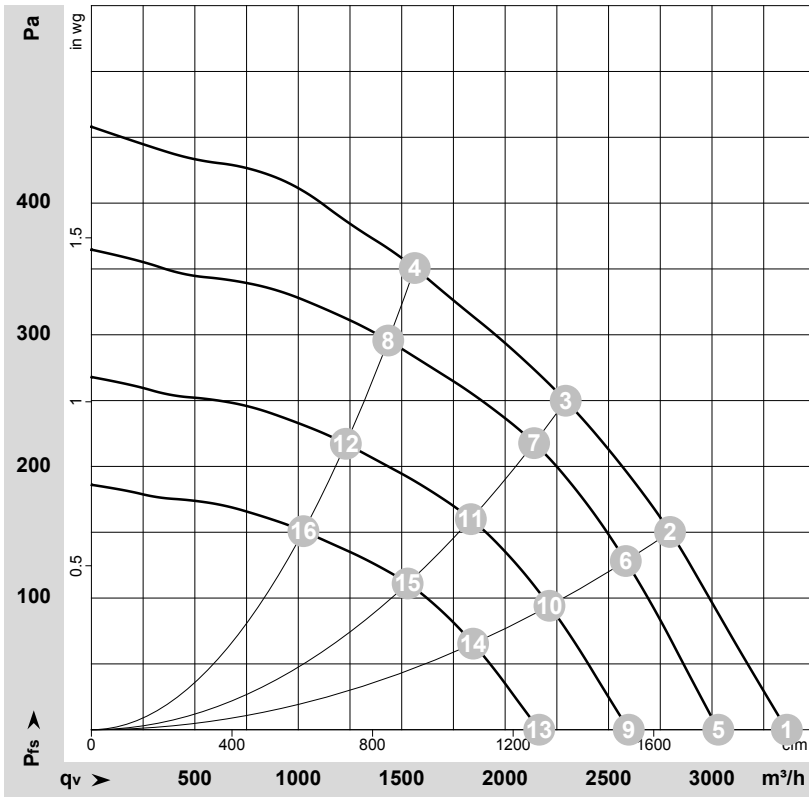

$\rho = 1.15 \text{ kg/m}^3 \pm 2 \%$

Measurement: LU-122643-1

Air performance measured according to ISO 5801 installation category A. For detailed information on the measurement setup, contact ebmpapst. Intake sound level: Sound power level according to ISO 13347 / sound pressure level measured at 1 m distance from fan axis. The values given are valid under the specified measuring conditions and may vary due to conditions of installation. For deviations from the standard configuration, the parameters have to be checked on the installed unit.

Measured values

	U	f	n	P _{ed}	I	q _v	P _{fs}	q _v	P _{fs}
	V	Hz	min ⁻¹	W	A	m ³ /h	Pa	cfm	inH ₂ O
1	115	50	1555	261	3.08	3360	0	1980	0.00
2	115	50	1515	304	3.54	2795	150	1645	0.60
3	115	50	1500	320	3.70	2295	250	1350	1.00
4	115	50	1525	297	3.47	1565	350	920	1.41
5	115	50	1400	191	2.25	3030	0	1785	0.00
6	115	50	1400	239	2.78	2585	129	1520	0.52
7	115	50	1400	259	3.01	2140	219	1260	0.88
8	115	50	1400	230	2.69	1435	296	845	1.19
9	115	50	1200	120	1.42	2600	0	1530	0.00
10	115	50	1200	150	1.75	2215	95	1305	0.38
11	115	50	1200	163	1.90	1835	161	1080	0.65
12	115	50	1200	145	1.69	1230	217	725	0.87
13	115	50	1000	70	0.82	2165	0	1275	0.00
14	115	50	1000	87	1.01	1845	66	1085	0.26
15	115	50	1000	94	1.10	1530	112	900	0.45
16	115	50	1000	84	0.98	1025	151	605	0.61

U = Power supply · f = Frequency · n = Speed (rpm) · P_{ed} = Power consumption · I = Current draw · q_v = Air flow · P_{fs} = Pressure increase

