

R3G355-AN04-72 ebmpapst Datasheet

sales@fansco.com

www.fansco.com

Limited partnership · Headquarters Mulfingen

Amtsgericht (court of registration) Stuttgart · HRA 590344

General partner Elektrobau Mulfingen GmbH · Headquarters Mulfingen

Amtsgericht (court of registration) Stuttgart · HRB 590142



Nominal data

Type	R3G355-AN04-72	
Motor	M3G084-FA	
Phase		1~
Nominal voltage	VAC	230
Nominal voltage range	VAC	200 .. 277
Frequency	Hz	50/60
Method of obtaining data		ml
Speed (rpm)	min ⁻¹	1710
Power consumption	W	450
Current draw	A	2.9
Min. ambient temperature	°C	-25
Max. ambient temperature	°C	40

ml = Max. load · me = Max. efficiency · fa = Free air · cs = Customer specification · ce = Customer equipment
Subject to change

Data according to ErP Directive

		Actual	Req. 2015			
01 Overall efficiency η_{es}	%	60.8	47.8	09 Power consumption P_{ed}	kW	0.44
02 Measurement category		A		09 Air flow q_v	m ³ /h	2185
03 Efficiency category		Static		09 Pressure increase p_{fs}	Pa	400
04 Efficiency grade N		75	62	10 Speed (rpm) n	min ⁻¹	1715
05 Variable speed drive		Yes		11 Specific ratio [*]		1.00

Data obtained at optimum efficiency level.

The ErP data is determined using a motor-impeller combination in a standardized measurement setup.

^{*} Specific ratio = $1 + p_{fs} / 100\,000\text{ Pa}$

LU-66839



Technical description

Weight	5.84 kg
Fan size	355 mm
Rotor surface	Painted black
Electronics housing material	Die-cast aluminum
Impeller material	Sheet aluminum
Number of blades	6
Direction of rotation	Clockwise, viewed toward rotor
Degree of protection	IP54
Insulation class	"B"
Moisture (F) / Environmental (H) protection class	F3-1
Max. permitted ambient temp. for motor (transport/storage)	+80 °C
Min. permitted ambient temp. for motor (transport/storage)	-40 °C
Installation position	Shaft horizontal or rotor on bottom; rotor on top on request
Condensation drainage holes	On rotor side
Mode	S1
Motor bearing	Ball bearing
Technical features	<ul style="list-style-type: none"> - Control input 0-10 VDC / PWM - Output 10 VDC, max. 1.1 mA - Thermal overload protection for electronics/motor - Alarm relay - Line undervoltage detection - Motor current limitation - Soft start
EMC immunity to interference	According to EN 61000-6-2 (industrial environment)
EMC circuit feedback	According to EN 61000-3-2/3
EMC interference emission	According to EN 61000-6-3 (household environment)
Touch current according to IEC 60990 (measuring circuit Fig. 4, TN system)	<= 3.5 mA
Motor protection	Thermal overload protector (TOP) internally connected
With cable	Variable
Protection class	I (with customer connection of protective earth)
Approval	CSA C22.2 No. 77; UL 2111

Product drawing

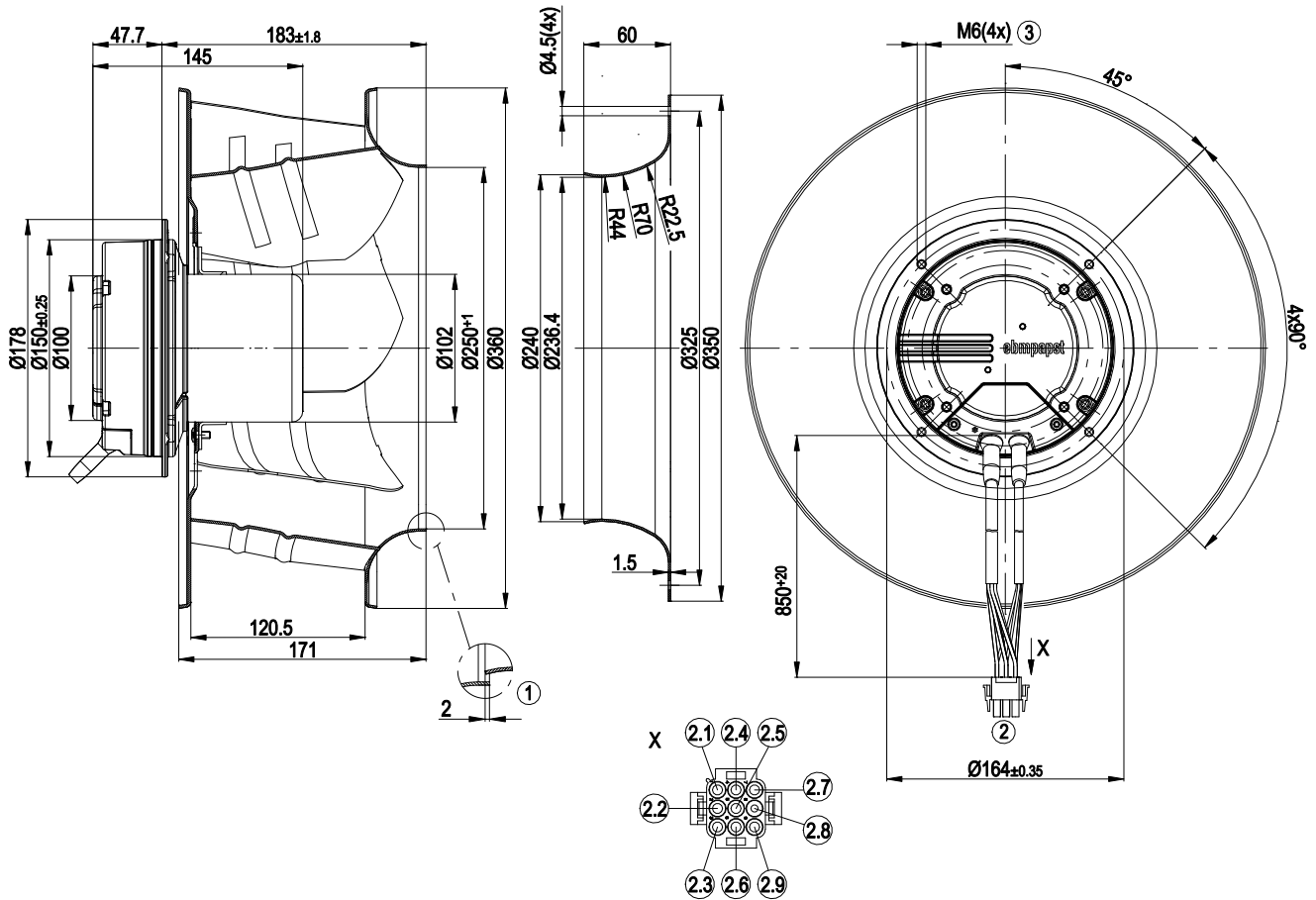

X	View X
1	Accessory part: Inlet ring 35560-2-4013 not included in scope of delivery, other inlet rings on request
2	Connector housing AMP 350 720-4 with 3 x plug pin AMP 926 885-1 and 5 x plug pin AMP 926 883-1
2.1	black
2.2	blue
2.3	green/yellow
2.4	white 1
2.5	white 2
2.6	not used
2.7	blue
2.8	red
2.9	yellow
3	Clearance for screw 8 - 10 mm

Connection diagram

Customer circuit

Application notes for various control options

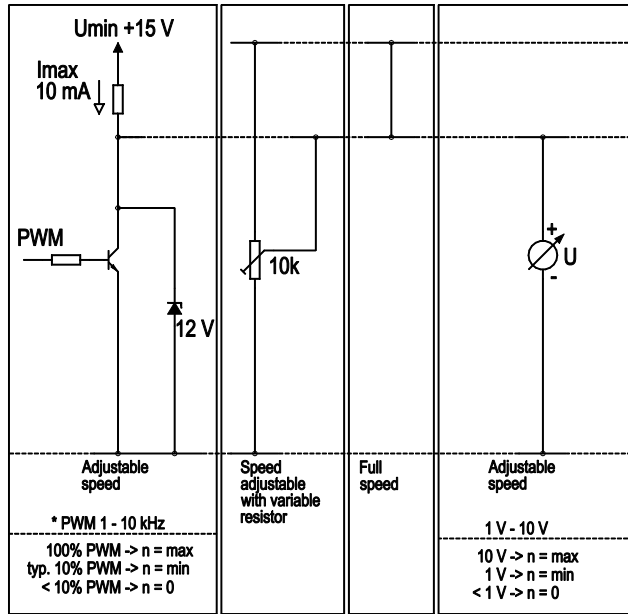

Connection

Fan / Motor

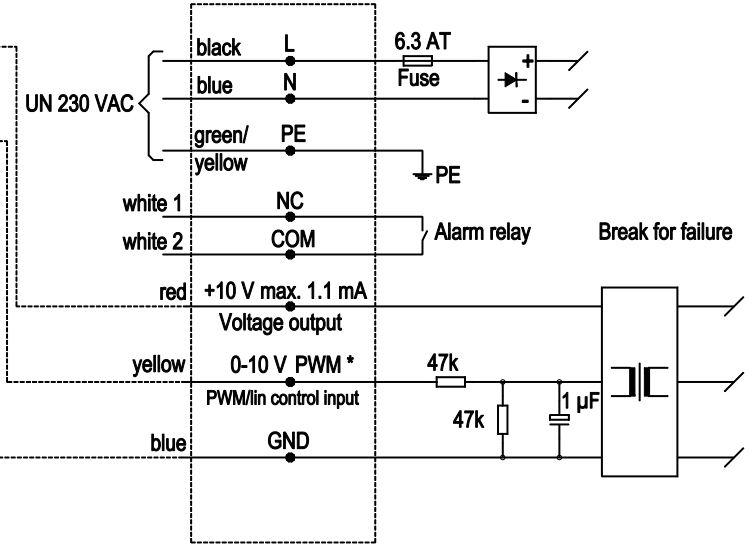

Curves: Air performance 50 Hz

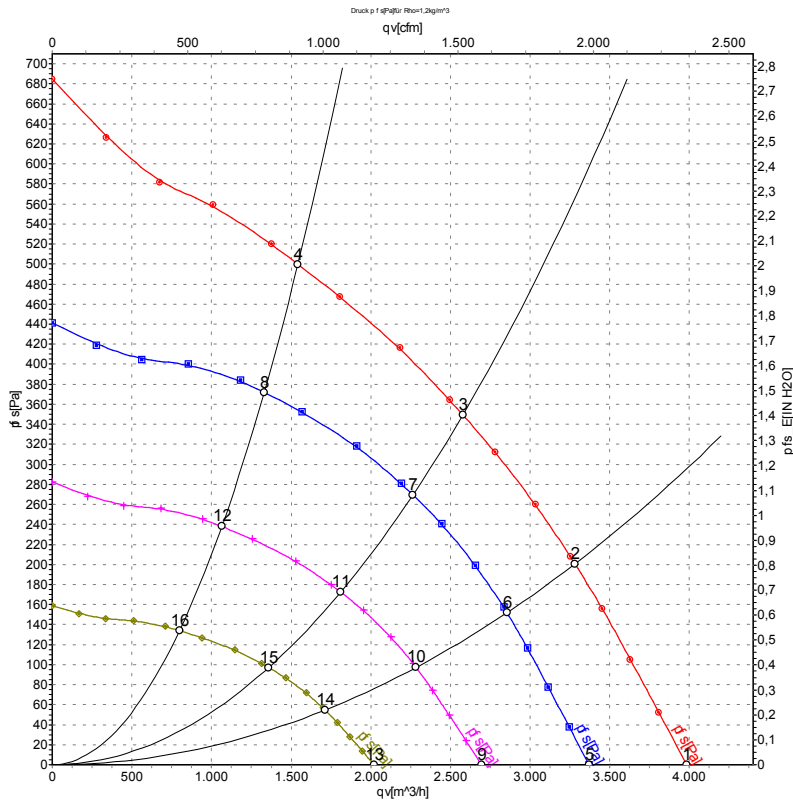

Measurement: LU-66839-1

Air performance measured according to ISO 5801 installation category A. For detailed information on the measurement setup, contact ebmpapst. Intake sound level: Sound power level according to ISO 13347 / sound pressure level measured at 1 m distance from fan axis. The values given are valid under the specified measuring conditions and may vary due to conditions of installation. For deviations from the standard configuration, the parameters have to be checked on the installed unit.

Measured values

	U	f	n	P _{ed}	I	qv	p _{fs}	qv	p _{fs}
	V	Hz	min ⁻¹	W	A	m ³ /h	Pa	CFM	inH2O
1	230	50	1775	362	2.31	3985	0	2345	0.00
2	230	50	1725	429	2.73	3280	200	1930	0.80
3	230	50	1710	450	2.90	2580	350	1515	1.41
4	230	50	1740	418	2.65	1545	500	910	2.01
5	230	50	1500	219	1.40	3370	0	1985	0.00
6	230	50	1500	283	1.80	2855	152	1680	0.61
7	230	50	1500	306	1.95	2265	270	1335	1.08
8	230	50	1500	268	1.70	1330	372	785	1.49
9	230	50	1200	112	0.72	2695	0	1585	0.00
10	230	50	1200	145	0.92	2285	98	1345	0.39
11	230	50	1200	157	1.00	1810	172	1065	0.69
12	230	50	1200	137	0.87	1065	238	625	0.96
13	230	50	900	47	0.30	2020	0	1190	0.00
14	230	50	900	61	0.39	1715	55	1010	0.22
15	230	50	900	66	0.42	1360	97	800	0.39
16	230	50	900	58	0.37	800	134	470	0.54

U = Power supply · f = Frequency · n = Speed (rpm) · P_{ed} = Power consumption · I = Current draw · qv = Air flow · p_{fs} = Pressure increase

