

# EC centrifugal fan

backward-curved, single-intake

for rail applications

R3G355-AM29-77 ebmpapst Datasheet

sales@fansco.com

www.fansco.com

Limited partnership · Headquarters Muldingen

Amtsgericht (court of registration) Stuttgart · HRA 590344

General partner Elektrobau Muldingen GmbH · Headquarters Muldingen

Amtsgericht (court of registration) Stuttgart · HRB 590142

## Nominal data

<b>Type</b>	<b>R3G355-AM29-77</b>	
<b>Motor</b>	<b>M3G084-FA</b>	
Phase		1~
Nominal voltage	VAC	230
Nominal voltage range	VAC	200 .. 277
Frequency	Hz	50/60
Method of obtaining data		ml
Speed (rpm)	min <sup>-1</sup>	1890
Power consumption	W	502
Current draw	A	3.15
Min. ambient temperature	°C	-25
Max. ambient temperature	°C	40

ml = Max. load · me = Max. efficiency · fa = Free air · cs = Customer specification · ce = Customer equipment  
Subject to change



# EC centrifugal fan

backward-curved, single-intake  
for rail applications

## Technical description

Weight	5.8 kg
Fan size	355 mm
Rotor surface	Painted black
Electronics housing material	Die-cast aluminum
Impeller material	Sheet aluminum
Number of blades	6
Direction of rotation	Clockwise, viewed toward rotor
Degree of protection	IP54
Insulation class	"B"
Moisture (F) / Environmental (H) protection class	F3-1
Max. permitted ambient temp. for motor (transport/storage)	+80 °C
Min. permitted ambient temp. for motor (transport/storage)	-40 °C
Installation position	Shaft horizontal or rotor on bottom; rotor on top on request
Condensation drainage holes	None
Mode	S1
Motor bearing	Ball bearing
Technical features	<ul style="list-style-type: none"> <li>- Output 10 VDC, max. 1.1 mA</li> <li>- Alarm relay</li> <li>- Motor current limitation</li> <li>- Soft start</li> <li>- Control input 0-10 VDC / PWM</li> <li>- Control interface with SELV potential safely disconnected from the mains</li> <li>- Thermal overload protection for electronics/motor</li> <li>- Line undervoltage detection</li> </ul>
Touch current according to IEC 60990 (measuring circuit Fig. 4, TN system)	<= 3.5 mA
Motor protection	Thermal overload protector (TOP) internally connected
With cable	Variable
Protection class	I (with customer connection of protective earth)
Conformity with standards	EN 61800-5-1; CE
Approval	CSA C22.2 No. 77; UL 2111



# EC centrifugal fan

backward-curved, single-intake  
for rail applications

## Product drawing

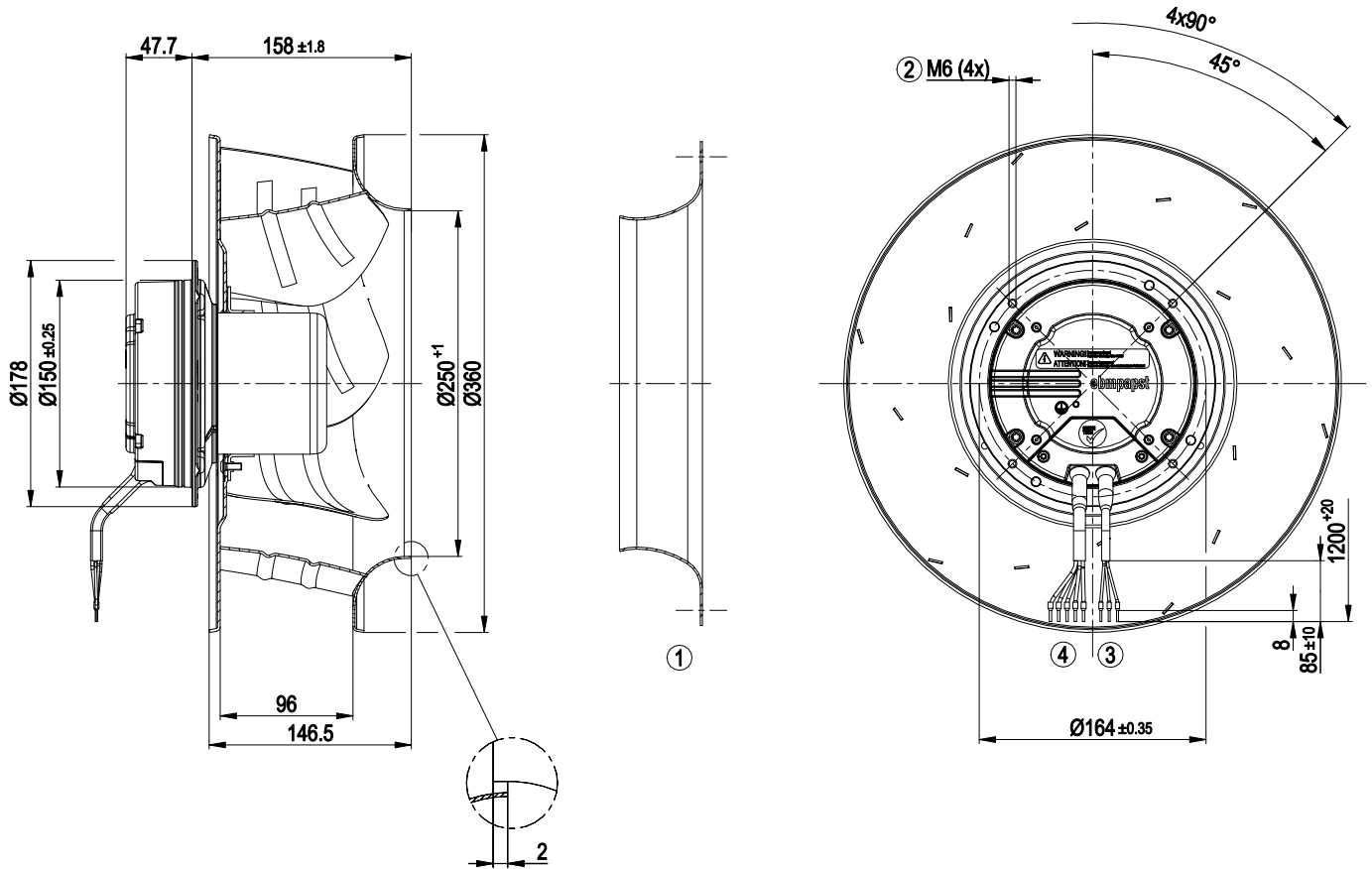

1	Accessory part: inlet ring 35560-2-4013 not included in scope of delivery
2	Max. clearance for screw 10 mm
3	Cable silicone 3x 0.34 mm <sup>2</sup> , 3x crimped ferrules
4	Cable silicone 5G 1.0 mm <sup>2</sup> , 5x crimped ferrules



# EC centrifugal fan

backward-curved, single-intake  
for rail applications

## Accessory part

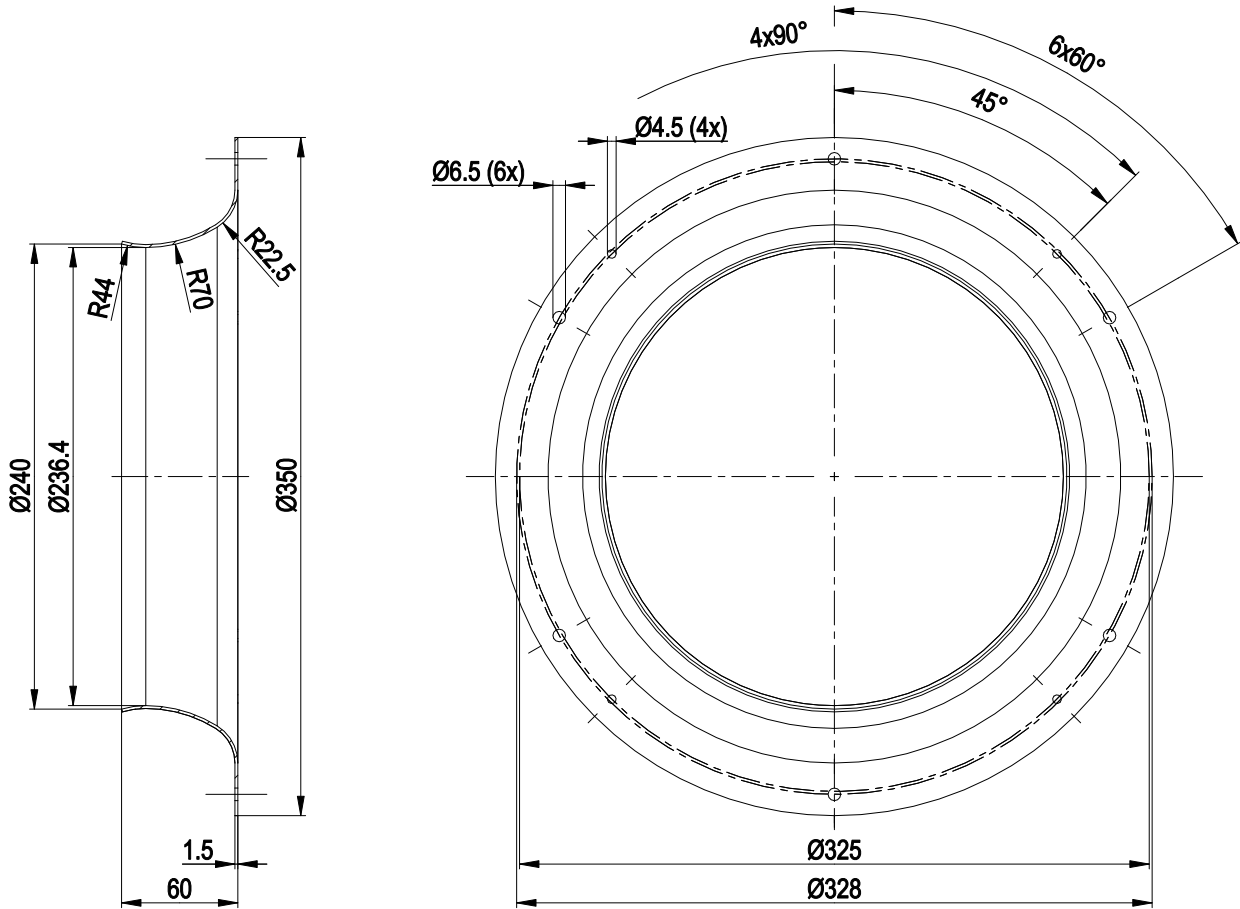

# EC centrifugal fan

backward-curved, single-intake  
for rail applications

## Connection diagram

Customer circuit

Application notes for various control options

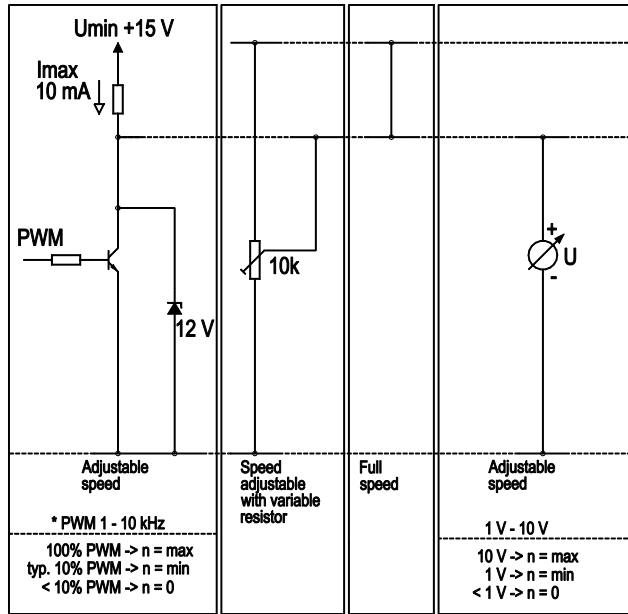

Connection

Fan / Motor

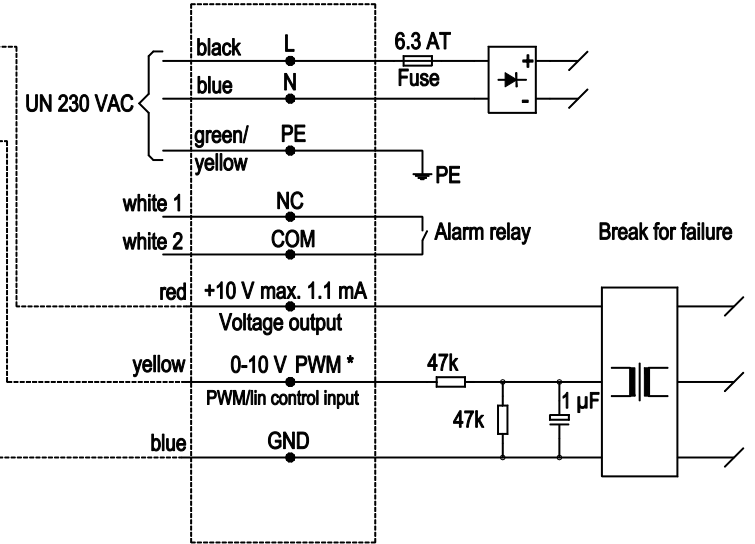

## Curves: Air performance 50 Hz

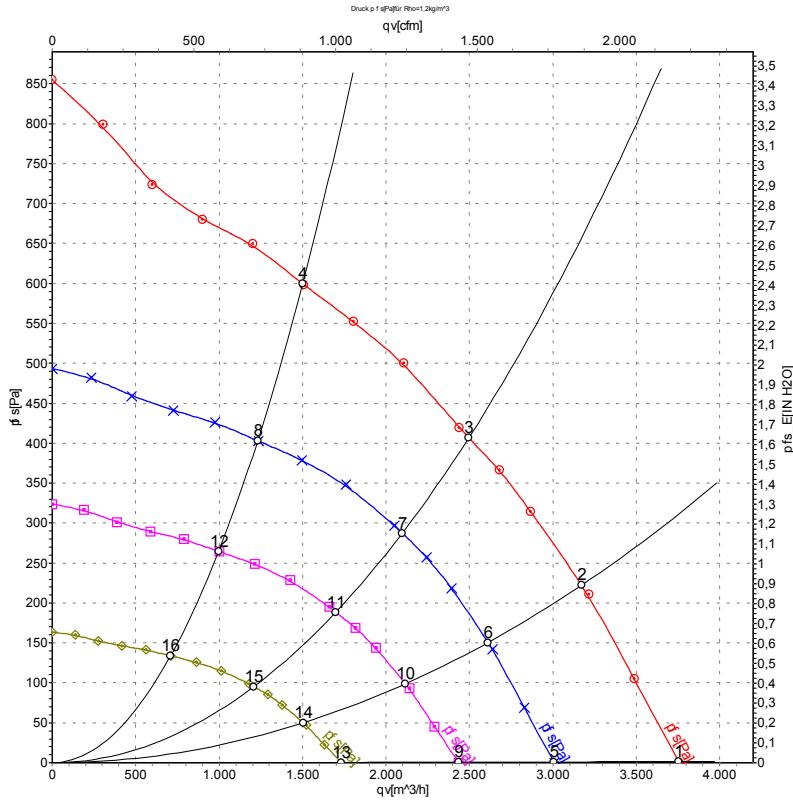

Measurement: LU-68189-1

Air performance measured according to ISO 5801 installation category A. For detailed information on the measurement setup, contact ebm-papst. Intake sound level: Sound power level according to ISO 13347 / sound pressure level measured at 1 m distance from fan axis. The values given are valid under the specified measuring conditions and may vary due to conditions of installation. For deviations from the standard configuration, the parameters have to be checked on the installed unit.

## Measured values

	U	f	n	P <sub>ed</sub>	I	LpA <sub>in</sub>	qv	p <sub>fs</sub>	qv	p <sub>fs</sub>
	V	Hz	min <sup>-1</sup>	W	A	dB(A)	m <sup>3</sup> /h	Pa	CFM	inH2O
1	230	50	1975	391	2.48	77	3750	0	2210	0.00
2	230	50	1920	468	2.95	73	3170	225	1865	0.90
3	230	50	1890	502	3.15	69	2495	405	1470	1.63
4	230	50	1925	473	2.99	71	1500	600	885	2.41
5	230	50	1580	201	1.27	71	3005	0	1770	0.00
6	230	50	1580	261	1.64	67	2610	152	1535	0.61
7	230	50	1580	298	1.89	64	2100	288	1235	1.16
8	230	50	1580	261	1.65	64	1230	403	725	1.62
9	230	50	1280	107	0.68	65	2435	0	1435	0.00
10	230	50	1280	139	0.87	61	2115	100	1245	0.40
11	230	50	1280	159	1.01	58	1700	189	1000	0.76
12	230	50	1280	139	0.88	59	995	265	585	1.06
13	230	50	910	38	0.24	55	1730	0	1020	0.00
14	230	50	910	50	0.31	52	1505	50	885	0.20
15	230	50	910	57	0.36	49	1210	95	710	0.38
16	230	50	910	50	0.32	50	710	134	415	0.54

U = Power supply · f = Frequency · n = Speed (rpm) · P<sub>ed</sub> = Power consumption · I = Current draw · LpA<sub>in</sub> = Sound pressure level intake side · qv = Air flow · p<sub>fs</sub> = Pressure increase

